

Assembly Instructions

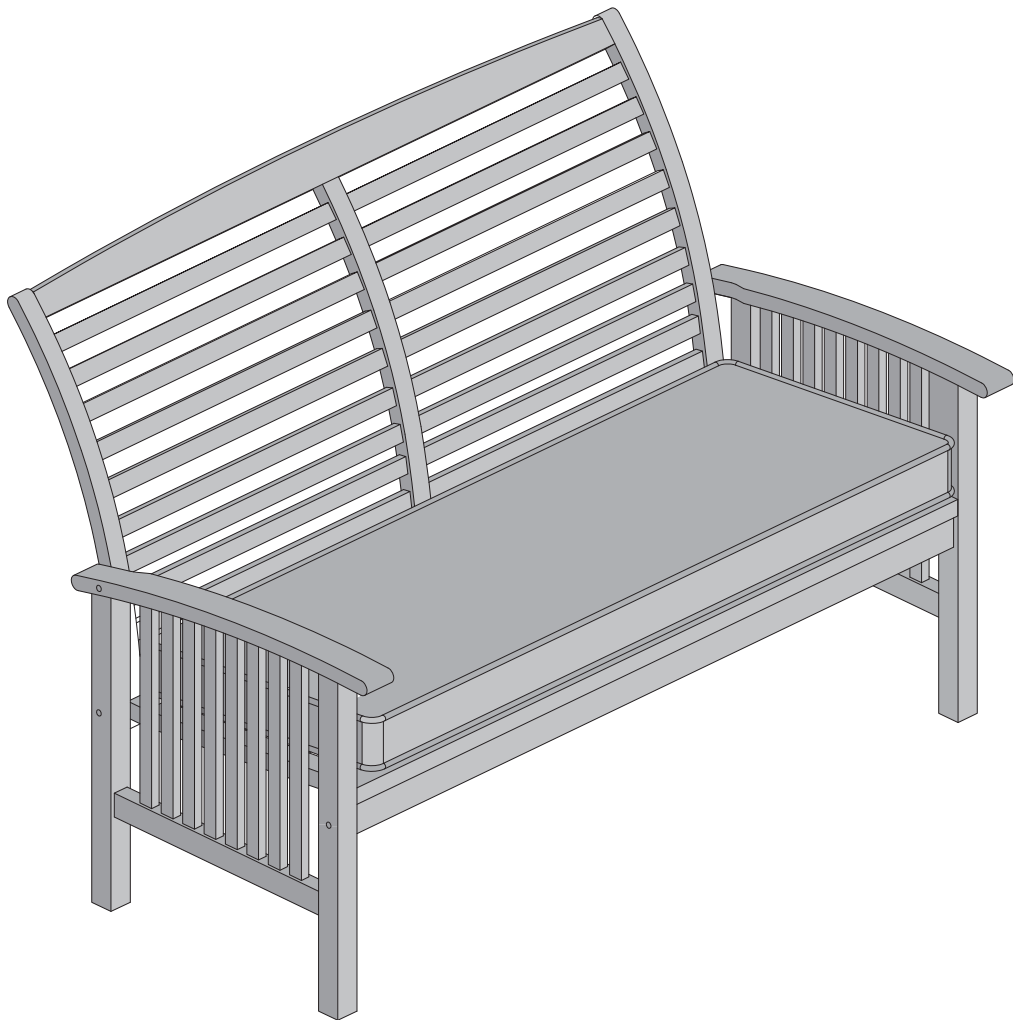

Parts List

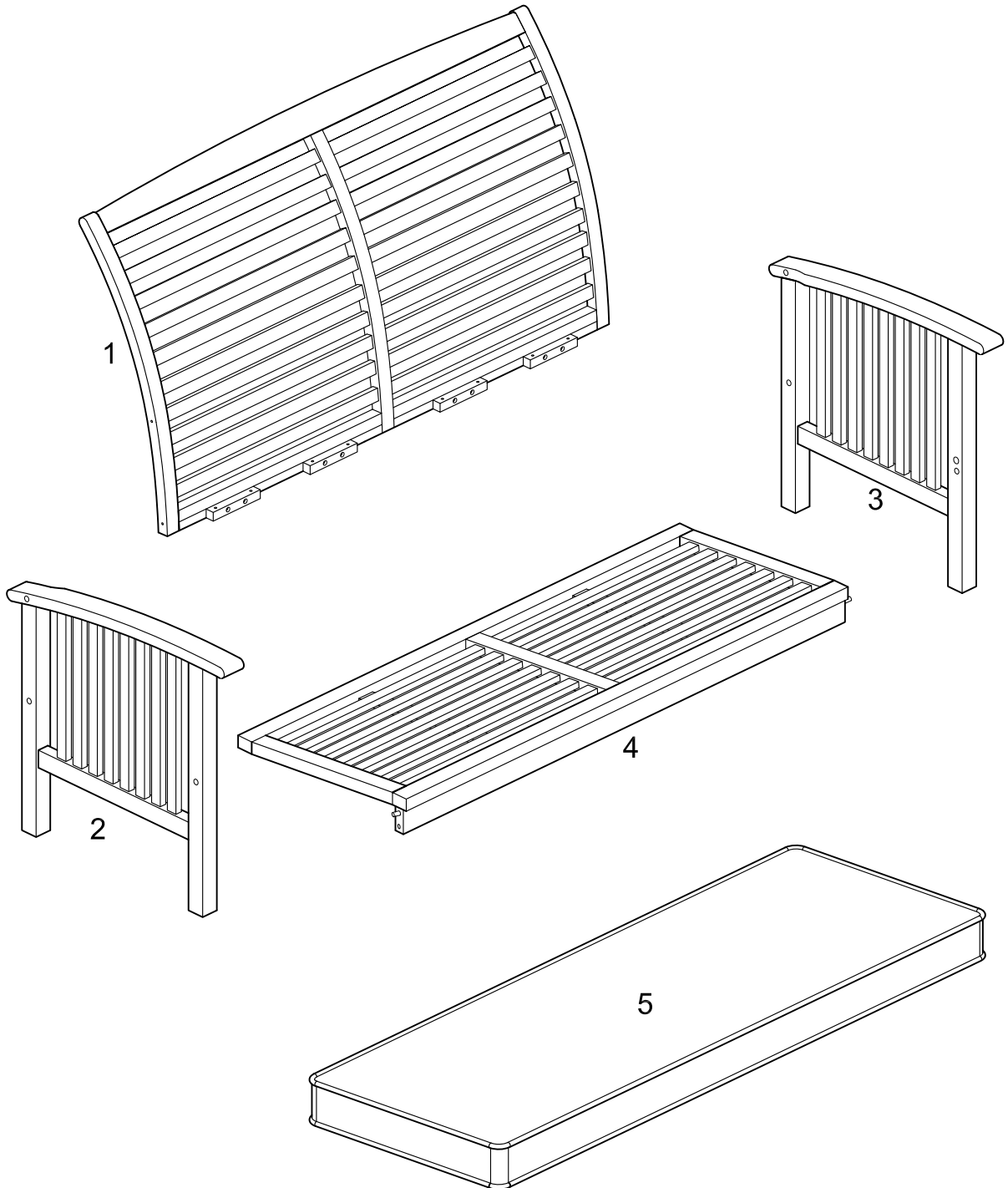

Hardware List

A		Ø8x80mm	Large Bolt	6 pcs
B			Barrel nut	4 pcs
C		Ø4x30mm	Screw	8 pcs
D			Wrench	1 pc

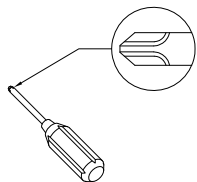

Phillips head screwdriver for the assembly
(not included)

*The hardware quantities listed above are required for proper assembly.
Some extra hardware may also have been included.*

Step 1

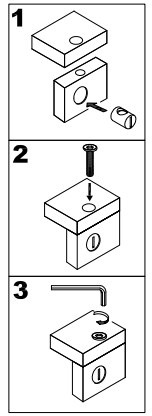
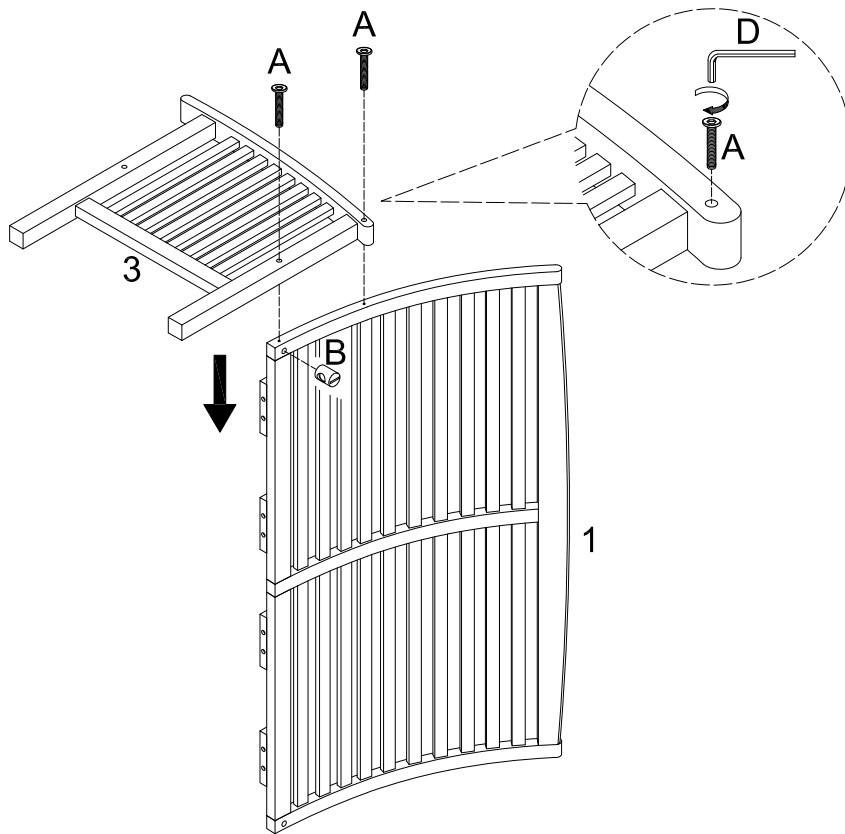

Insert barrel nuts (B) into chair back (1). Attach chair side (3) to chair back (1) using bolt (A). Bolt (A) will be inserted through chair side (3) and will screw into barrel nuts (B). Tighten bolts (A) firmly with wrench (D).

Step 2

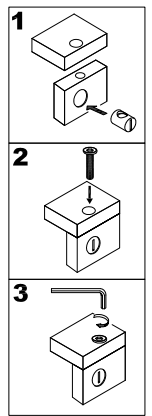
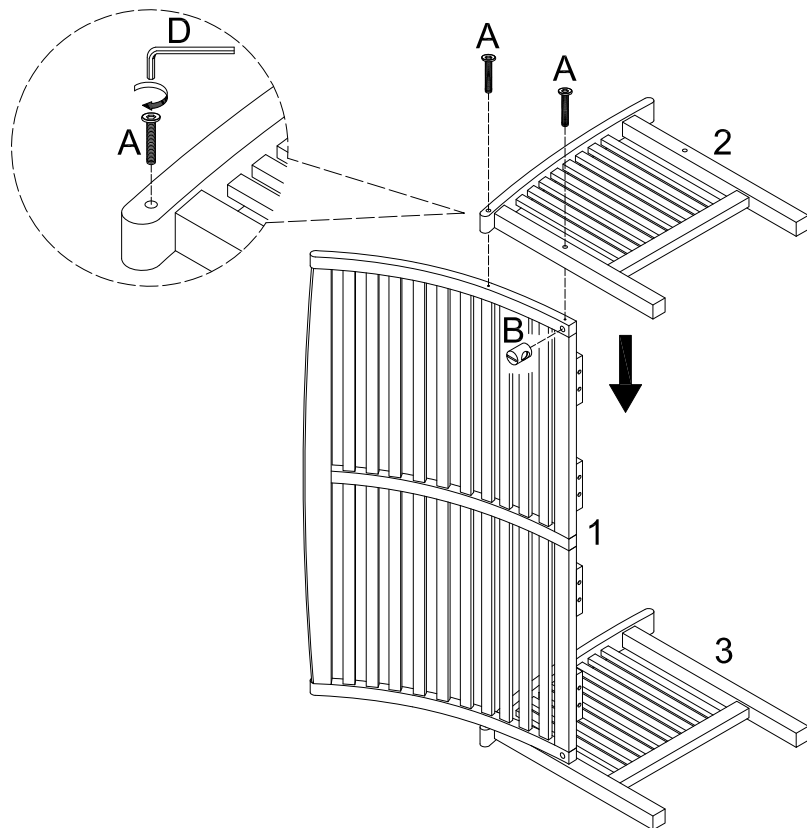

Insert barrel nuts (B) into chair back (1). Attach chair side (2) to chair back (1) using bolt (A). Bolt (A) will be inserted through chair side (2) and will screw into barrel nuts (B). Tighten bolts (A) firmly with wrench (D).

Step 3

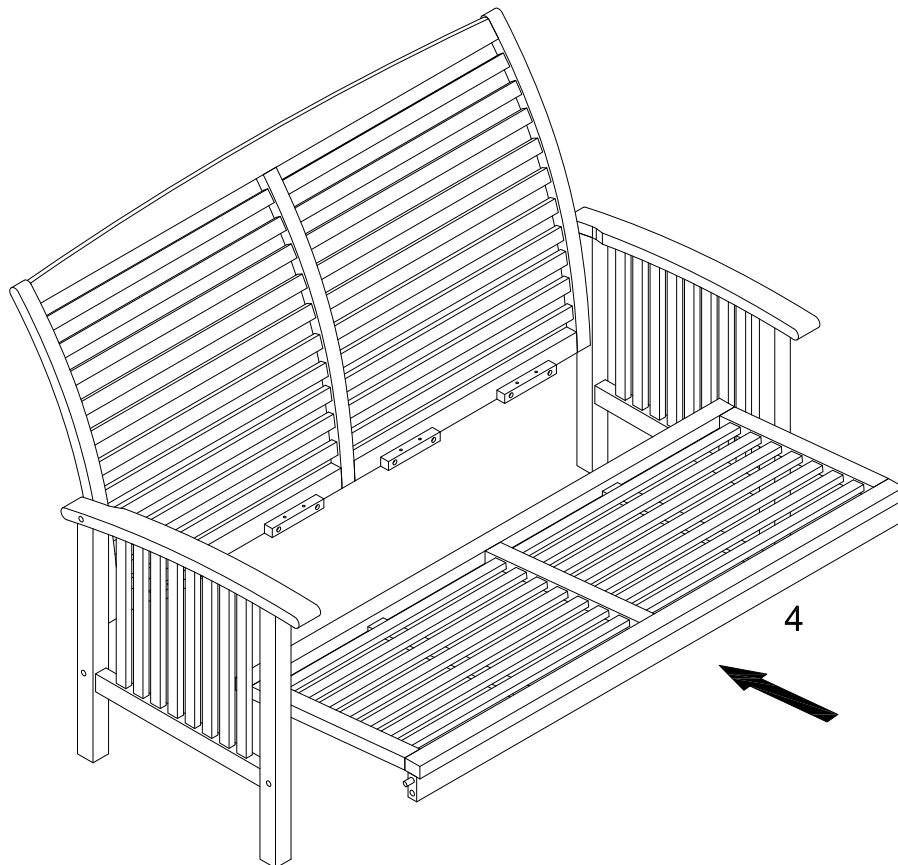

Insert chair seat (4) into stand.

Step 4

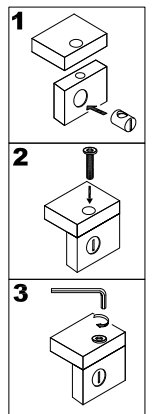
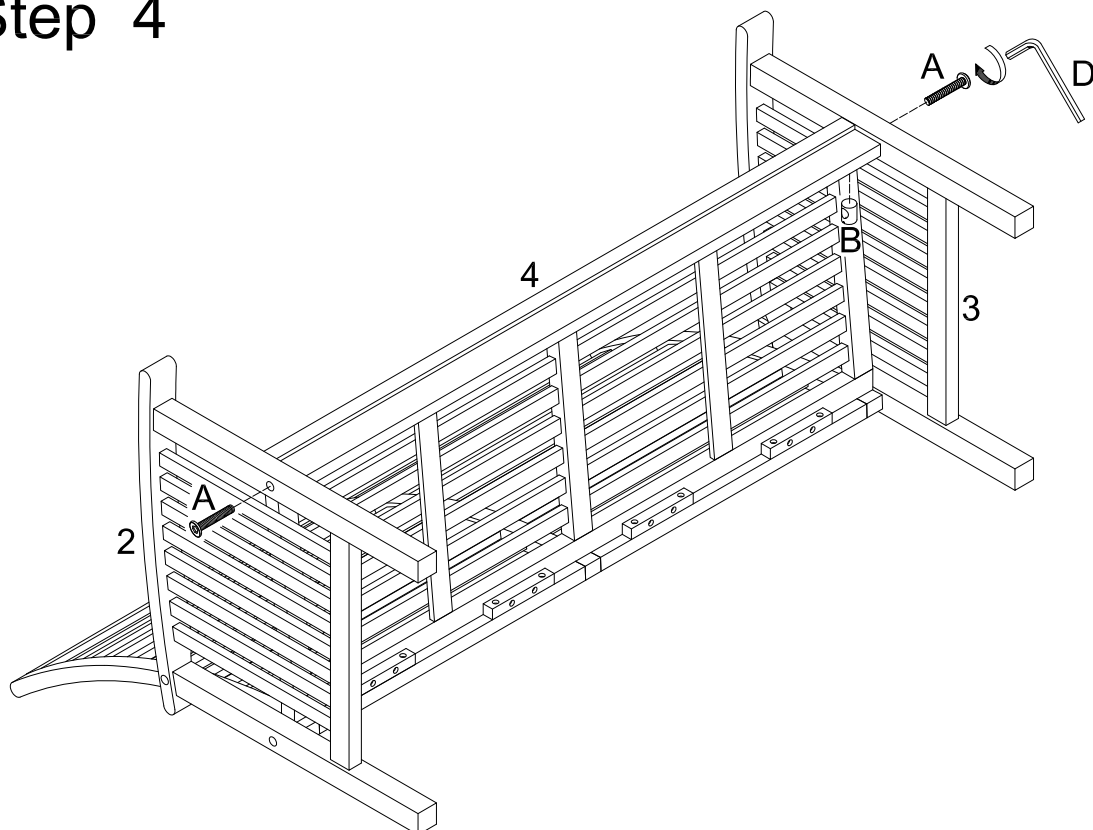

Insert barrel nuts (B) into chair seat (4). Attach chair side (4) into the chair side (2&3) using bolt (A). Bolt (A) will be insert through chair side (2&3) and will be screw into barrel nuts (B). Tighten bolts (A) firmly with wrench.

Step 5

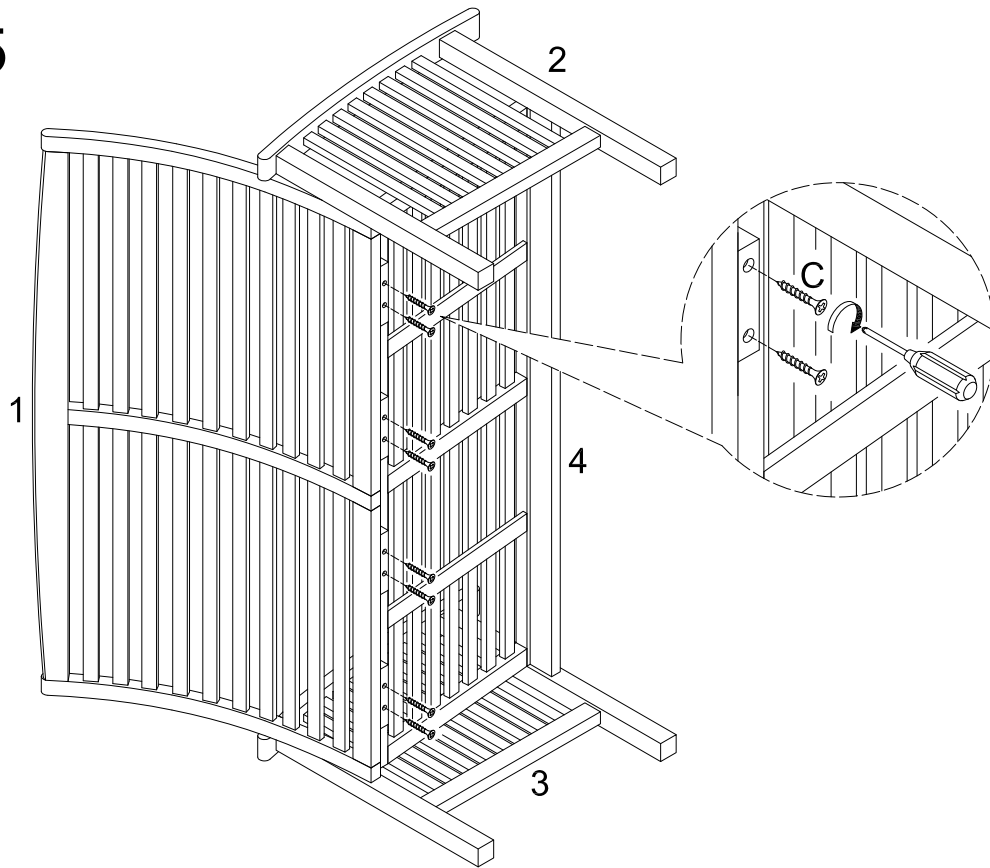

Secure chair seat (4) to chair back (1) using screws (C). Tighten screws (C) firmly with a screwdriver.

Step 6

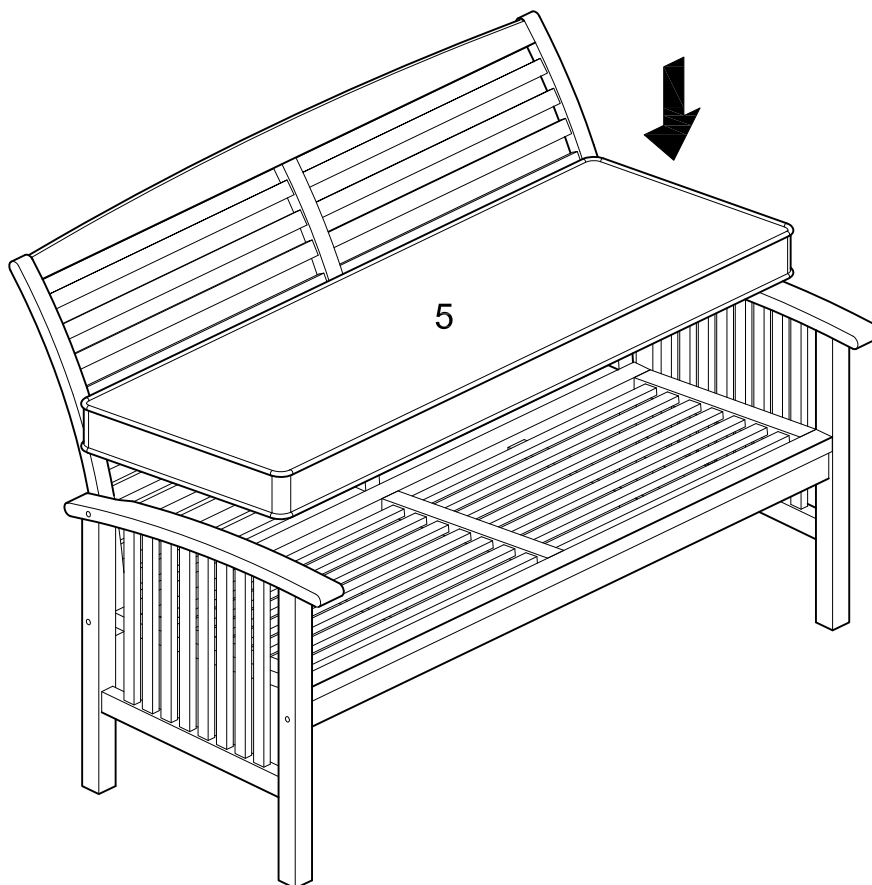

Put a cushion (5) on the chair seat.

Step 7

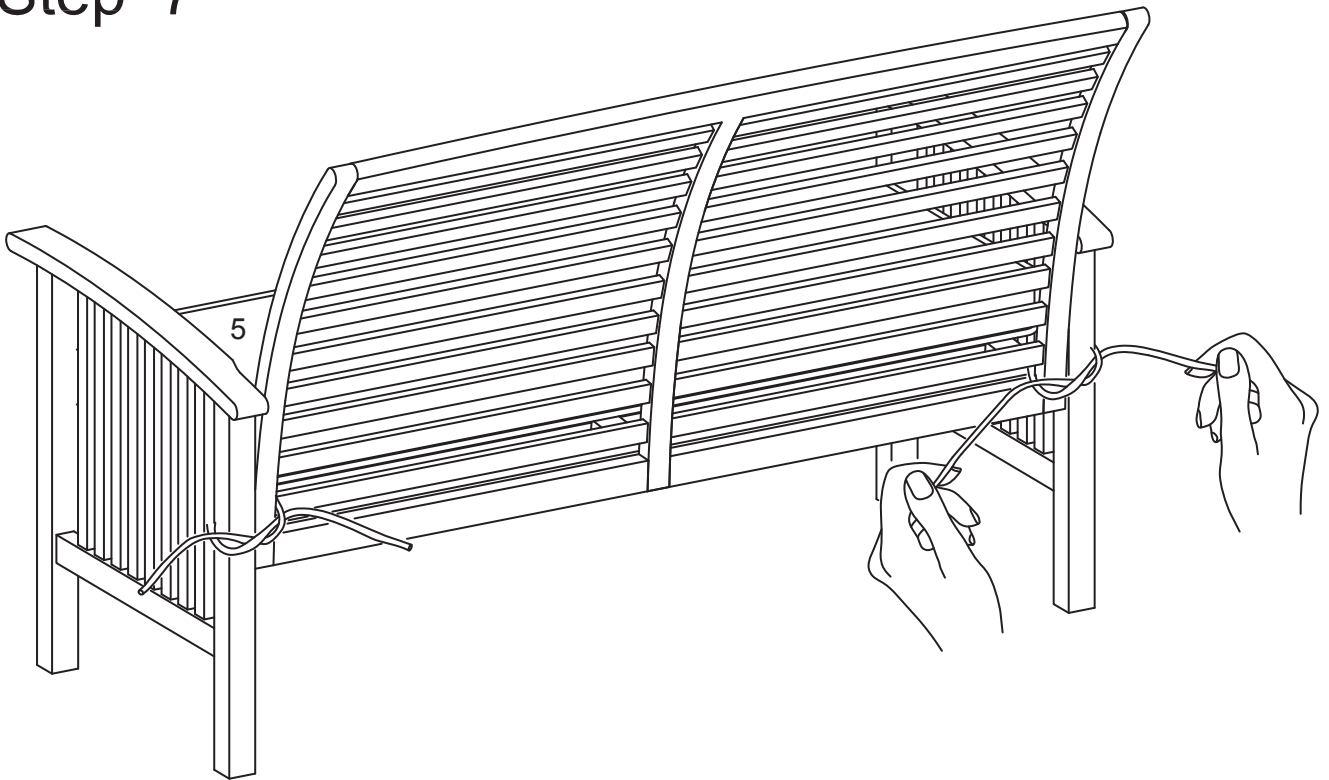

Secure the cushion to the chair frame by tying the back strings as shown in the diagram.

Step 8

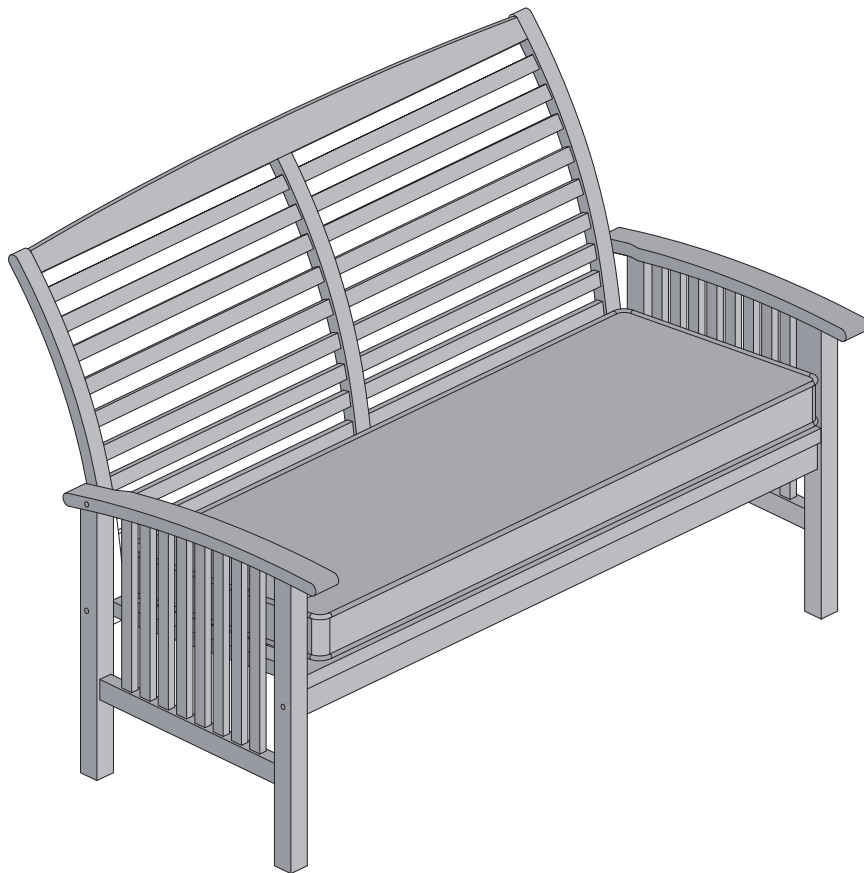

Final Assembly