

WARRANTY

We strive to offer high-quality products, and we also try our best to satisfy each and every customer that orders from us with product or service as needed.

Each customer must provide a record of their order such as the order number, or item receipt for any items that are out of the warranty period you may also still receive replacement parts by purchasing them with our company if they are available.

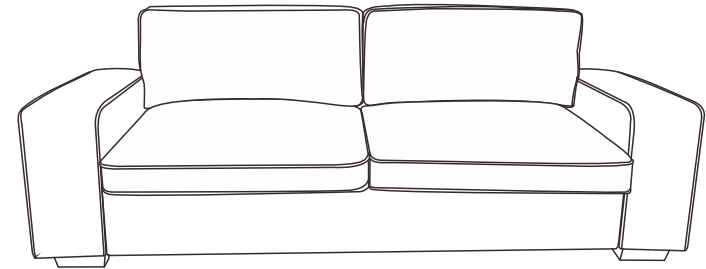

NOTE:

This brochure contains IMPORTANT safety info. Please read and keep for reference.

MAINTAINANCE AND WARNING





- Keep furniture away from heat and fire
- Keep furniture away from sharp objects.
- Do not clean furniture with harsh cleansers or polish. Do not use detergents, Solvents, abrasives, spray packs or leather cleaner. Use non-color mild soap with warm water clean spills(Mix 1:10 soap to water)
- Do not place furniture under direct sunlight material will possibly fade over time.
- Do not jump or strike on the furniture.
- Do not write on furniture without a padded barrier to protect the surface.
- Not for commercial use, For residential use only.





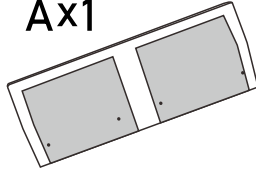
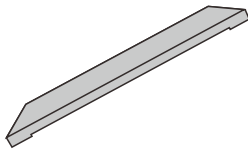
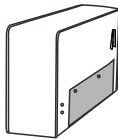
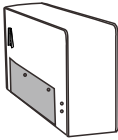
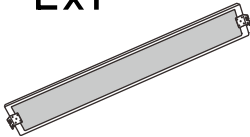
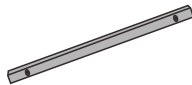
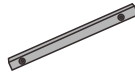

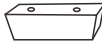
Weight Limitation

220LBS PER SEAT UNIT

PARTS LIST

Ax1  Back frame	Bx1  Seat frame	Cx1  Left armrest	Dx1  Right armrest
Ex1  Front rail	Fx4  back and front rail bar	Gx2  side rail bar	Hx2  Seat cushion
Ix2  Back cushion (Packed in armrests)	Jx4  leg	Kx4  Cover of seat cushion	Lx4  Cover of back cushion

HARDWARE & TOOL LIST

① x12  M6*40mm Bolt	② x4  M8*20mm Bolt	③ x8  M8*60mm	④ x20  Washer	⑤ x1  Allen key
--	---	--	--	--

Be sure to check all packing material fit the packing list. Carefully for small parts, which may have some loose inside the carton during shipment.

ASSEMBLY INSTRUCTIONS

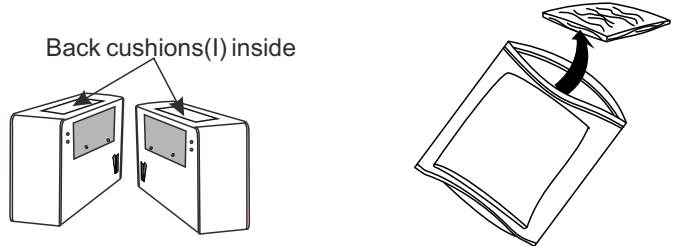

STEP 1: Take the back cushions and seat cushions from the vacuum bags, let them expand for a while. (Back cushions are packed in armrests. Take them out from bottom of armrests.)

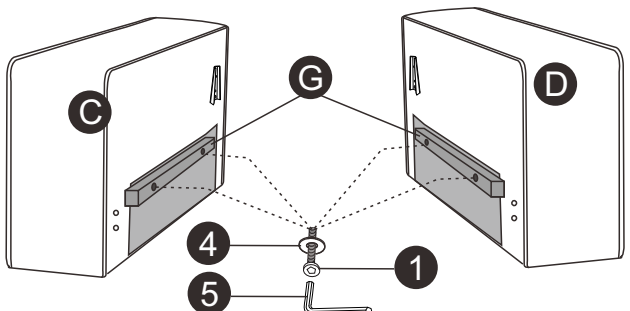

STEP 2: Attach the side rail bars (G) to the armrests (C,D) with bolts (1), washer(4) and allen key (5)

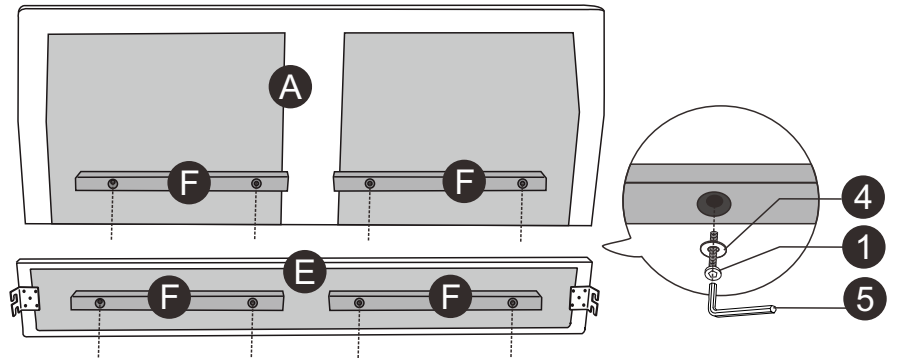

STEP 3: Attach the back and front rail bars (F) to the back frame (A) and front rail with bolts (1), washer(4) and allen key (5)

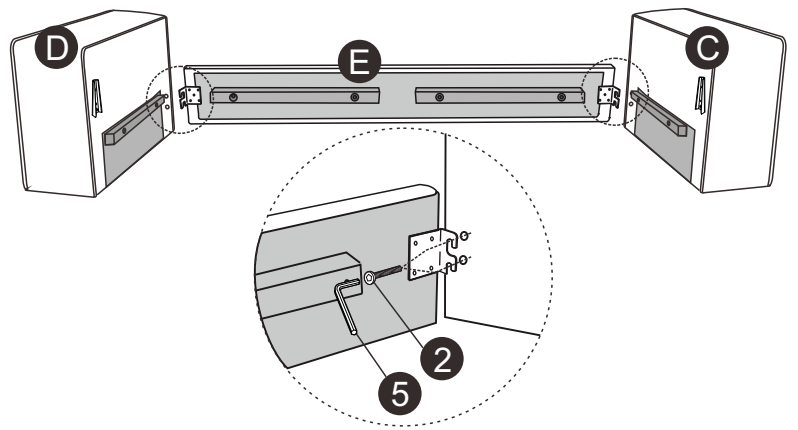

STEP 4: Attach front rail (E) to armrests (C,D) with bolts (2) and allen key (5).

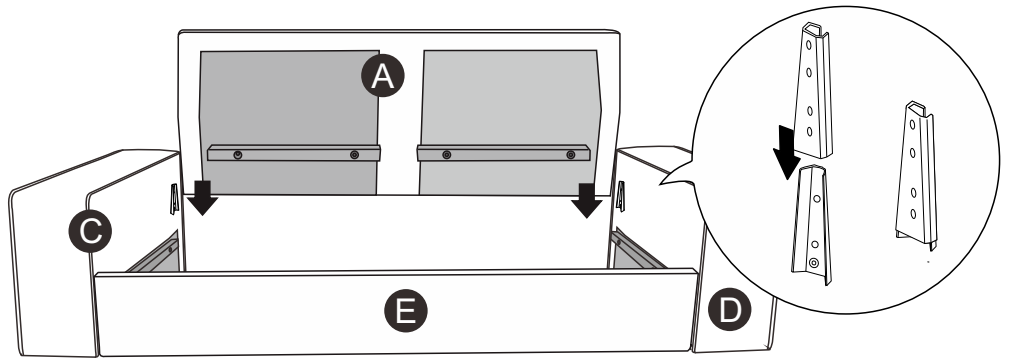

STEP 5: Attach backrest to armrest. Insert both connectors at the same time, push hard to connect fully.

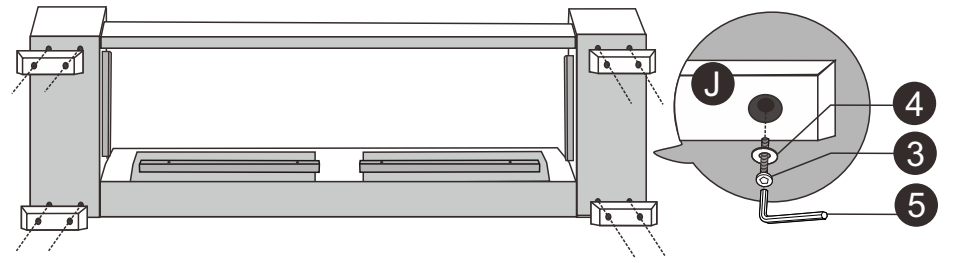

STEP 6: Screw legs (J) in to bottom of armrest with bolts(3), washer(4) and allen key(5).

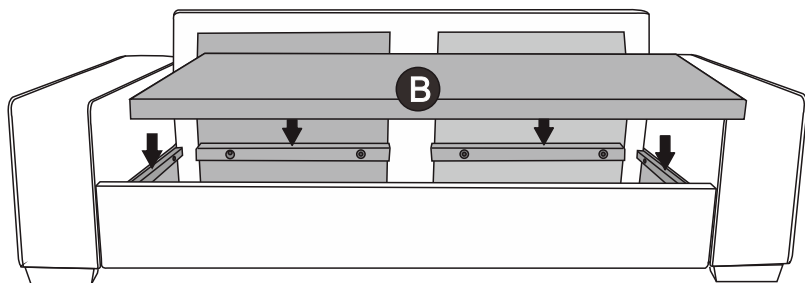

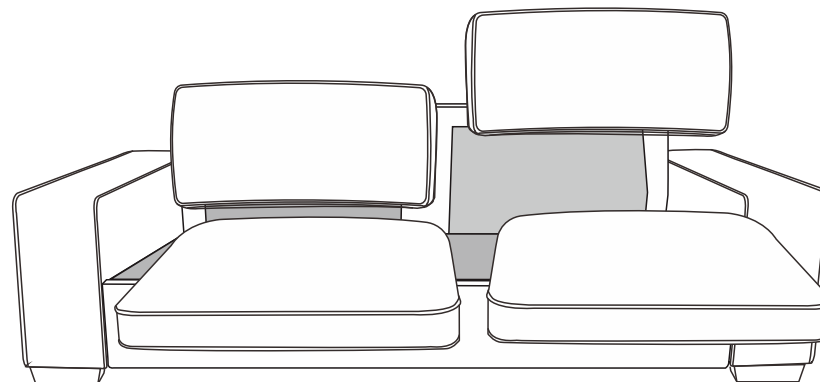

STEP 7: Place seat frame (B) on to the rails.

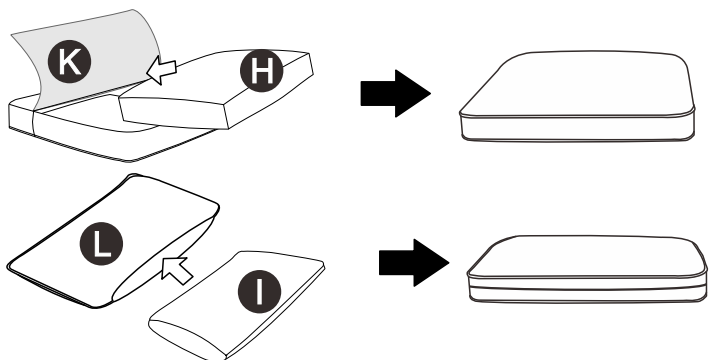

 It will take a while for the cushions to expand. Normally it will take up to around 24 hours to expand to its full size.

STEP 9: Place seat cushions and back cushions on to seat frame and back frame.



 It will take a while for the cushions to expand. Normally it will take up to around 24 hours to expand to its full size.

STEP 8: Put seat cushions(H) and back cushions(I) into covers(K,L) and zip up.

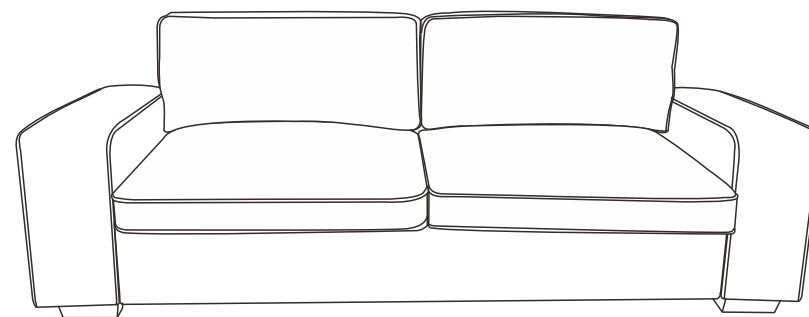

STEP 10: Assembly completed.