

WARRANTY

We strive to offer high-quality products, and we also try our best to satisfy each and every customer that orders from us with product or service as needed.

Each customer must provide a record of their order such as the order number, or item receipt for any items that are out of the warranty period you may also still receive replacement parts by purchasing them with our company if they are available.

**Are you having difficulty
with assembly? Missing parts?**

Please contact us : info@firstopintl.com

telephone No.:5627813327

send email with your order No. to

**For return, please check the return policy with
the retailer or market place you bought from.**

Appreciate your purchasing from us.

Pop up your life by our furniture !

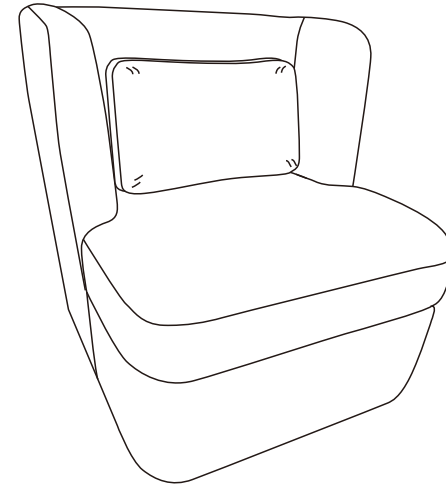
The logo for Wixé, featuring the word "wixé" in a bold, lowercase, sans-serif font. The letter "i" is stylized with a grey dot and a grey vertical bar extending downwards.

ITEM NO.CH0031

NOTE:

This brochure contains IMPORTANT safety info. Please read and keep for future reference.

MAINTAINANCE AND WARNING

- Keep furniture away from heat and fire.
- Keep furniture away from sharp objects.
- Do not clean furniture with harsh cleansers or polish. Do not use detergents, Solvents, abrasives, spray packs or leather cleaner. Use non-color mild soap with warm water clean spills(Mix 1:10 soap to water)
- Do not place furniture under direct sunlight, material will possibly fade over time.
- Do not jump or strike on the furniture.
- Do not write on furniture without a padded barrier to protect the surface.
- Not for commercial use, For residential use only.



Weight Limitation

400LBS

PARTS LIST

A*1

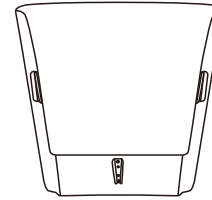

Backrest part

B*1

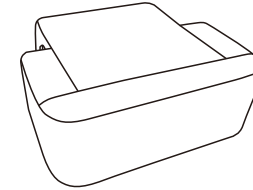

Seat frame

C*1

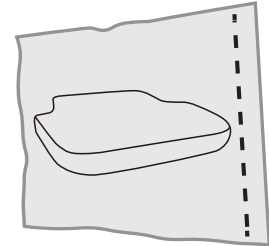

Seat cushion

D*1



Backrest part

E*1

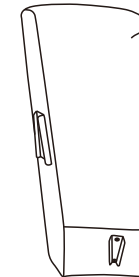

Backrest part

F*1

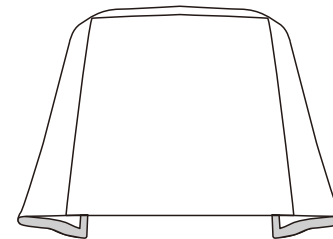

Cover of backrest

G*1



Back cushion

ASSEMBLY INSTRUCTIONS



Assembly =2 persons

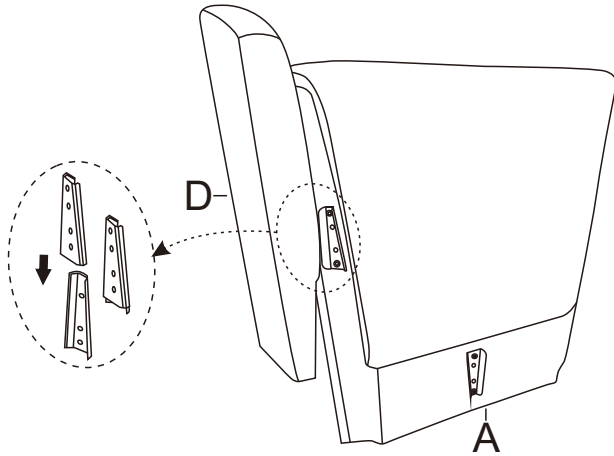

STEP 1: Attach backrest part(D) to backrest part(A). Insert both connectors at the same time, push hard to connect fully.

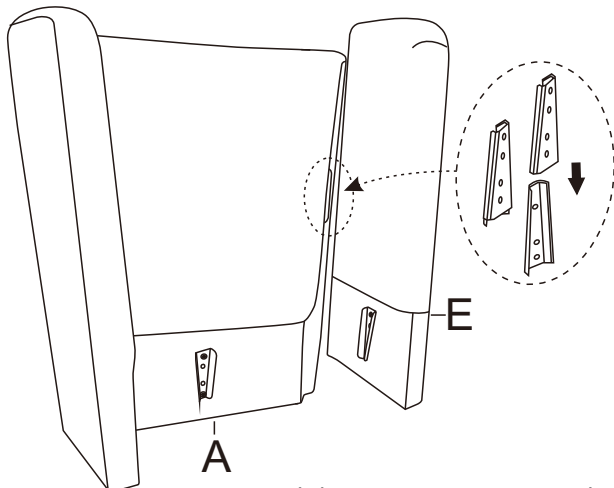

STEP 2: Attach backrest part(E) to backrest part(A). Insert both connectors at the same time, push hard to connect fully.



Assembly =2 persons

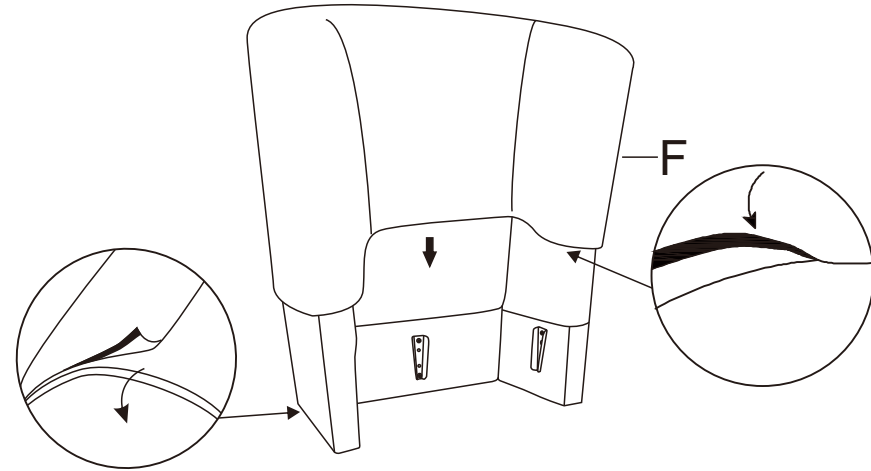

STEP 3: Attach the cover(F) to the backrest part and velcro it in place.

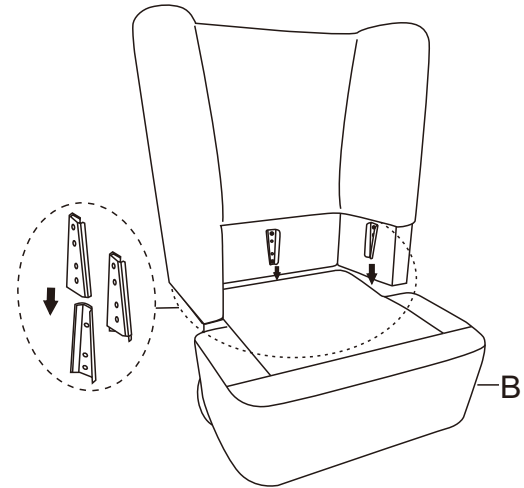

STEP 4: Attach backrest part to seat frame(B). Insert both connectors at the same time, push hard to connect fully.



Assembly =2 persons

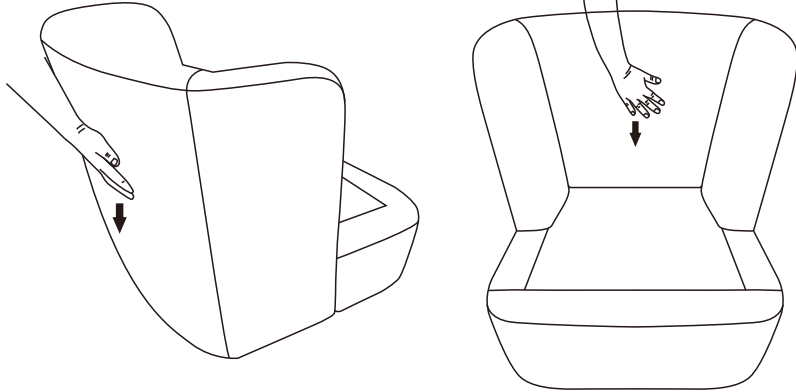

STEP 5:Organise the cover by hand to make it fit beautifully

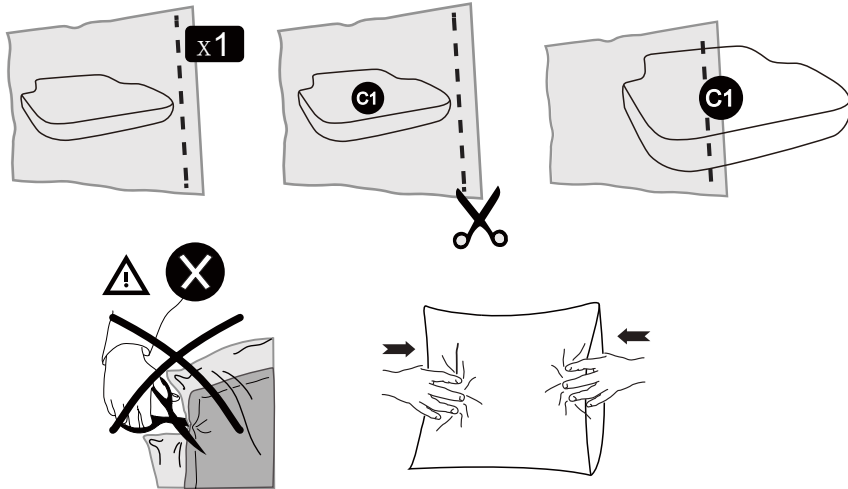

STEP 6:Please be careful not to cut the cushion when removing it.Patting with your hands can speed up recovery.



Assembly =2 persons

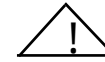
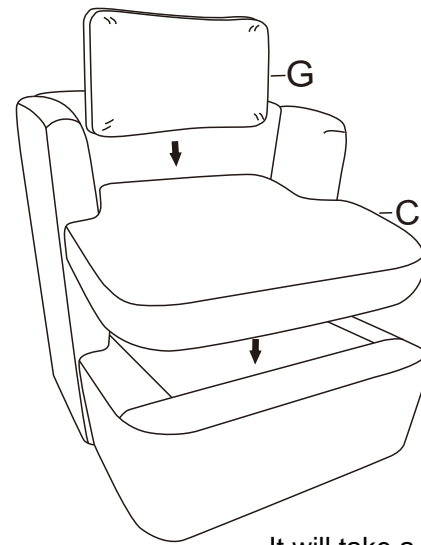

It will take a while for the cushions to expand.Normally it will take up to around 24 hours to expand to its full size.

STEP 7:Place seat cushions and back cushions on to seat frame and back frame.

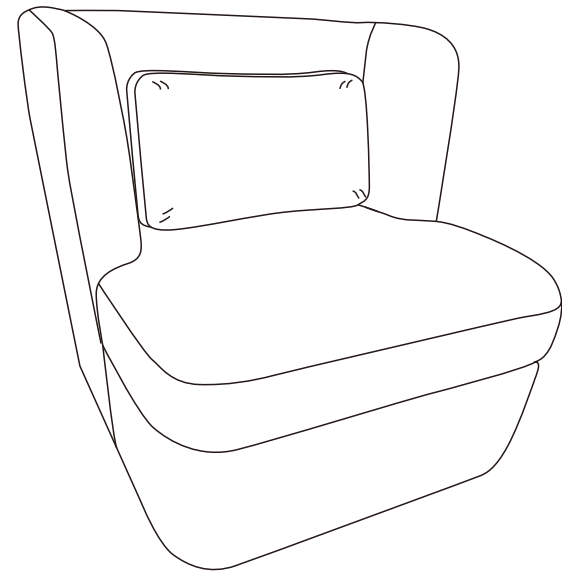

STEP 8:Assembly completed.