

Electric Height Adjustable Standing Desk

USER MANUAL

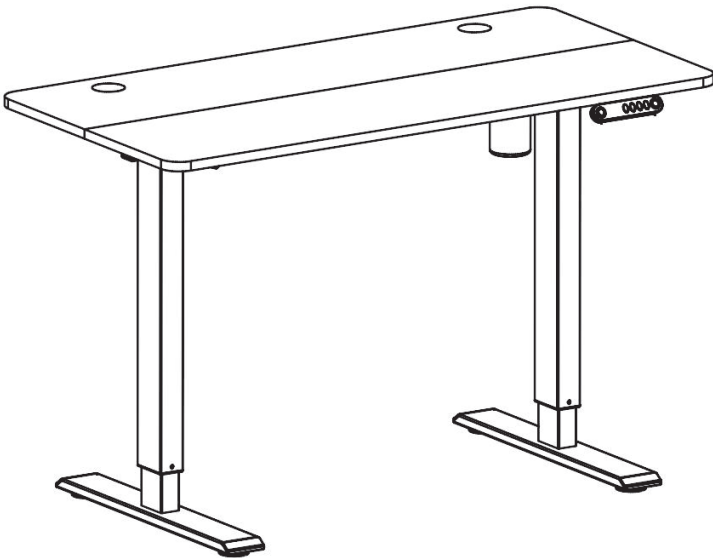



IMPORTANT INFORMATION
READ CAREFULLY.
KEEP THIS INFORMATION FOR FURTHER REFERENCE.

GENERAL GUIDELINES

- Please read the following instruction carefully and use the product accordingly.
- Please keep this manual and hand it over when you transfer the product.
- This summary may not include every detail of all variations and considered steps. Please **contact us** when further information and help are needed.

NOTES









- Please follow the assembly instructions precisely and only use the product as intended.
- If an odor is present when first opening the package, please leave the unwrapped product in a shaded and ventilated area for a few days to air out.
- Prior to assembly, please check the product for defects or missing accessories. If any defects are found or accessories are missing, do not use product as damage or injury may occur;
- Please **contact us** for assistance and replacement.
- During assembly, please only slightly tighten all screws in their correct position first, then fully tighten them. A Philips screwdriver is recommended but not included.
- It is suggested you regularly check the products bolts and connections to ensure safe use.
- Assemble the item on a soft flat and clean surface to avoid scratches and damage.

WARNINGS

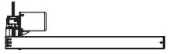
- During assembly, keep parts and packaging materials away from children and pets as there could cause injury and are a potential choking hazard.
- Avoid sharp objects or corrosive chemicals to prevent damage to the product.
- Please open the item slowly and cautiously to avoid pinching your hands by metal joints, especially children.

Components

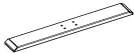
Please check you have all the pieces listed below



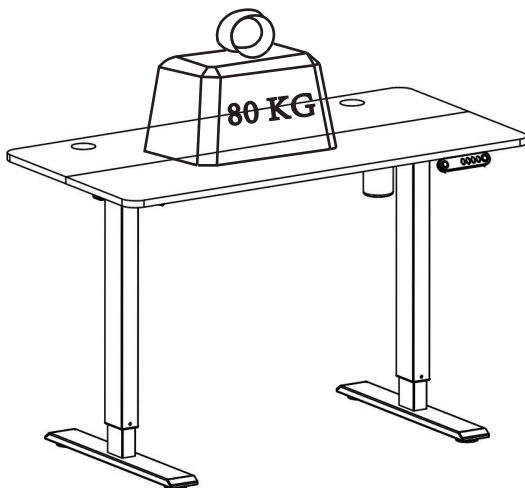





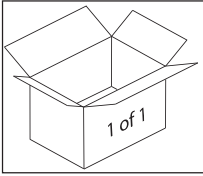

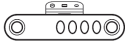



Part List				
Reference	Description	Part	Quantity	Material
①	Desktop-a		1	Particle Board
②	Desktop-b		1	Particle Board
③	Left Leg		1	Steel
④	Right Leg		1	Steel
⑤	Support Beam		2	Steel
⑥	Side Bracket		2	Steel
⑦	Base		2	Steel
⑧	Sync Rod		1	Aluminium

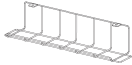

Components

Please check you have all the pieces listed below



<p>A  Power Cable x 1 pc</p>	<p>B  Controller x 1 pc</p>	<p>C  Leveling Studs x 4 pcs</p>
<p>D  Wire Clips x 5 pcs</p>	<p>E  4mm Allen Key x 1 pc</p>	
<p>G  Screws M6X12 x 28 pcs</p>	<p>H  Screws M5X8 x 14 pcs</p>	<p>I  Screws M6X30 x 10 pcs</p>
<p>J  Wooden Rod x 8 pcs</p>	<p>K  AC Adapter x 1 pc</p>	<p>L  Wire Basket x 1 pc</p>
<p>M  Hook x 2 pcs</p>	<p>N  Outlet Box x 2 pcs</p>	<p>O  Iron Connector x 2 pcs</p>
<p>P  Lockable wheel x 4 pcs</p>	<p>Q  Hexagon bar x 1 pcs</p>	

1

J	X 6
Wooden Rod	

Note: Two more wooden rods in the accessory bag

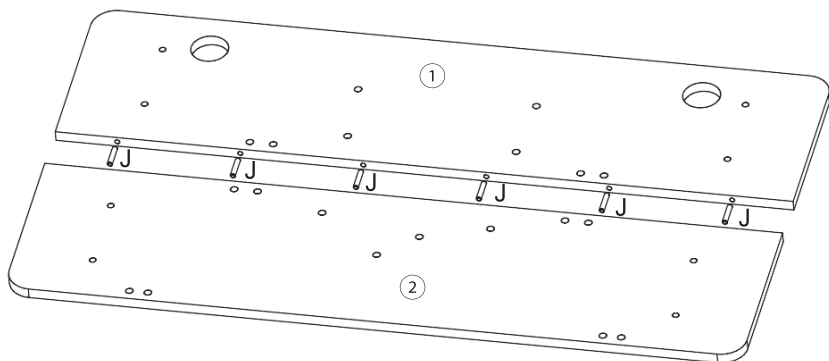
**2**

E	X 1	G	X 8	O	X 2
4mm Allen Key		Screws M6X12		Iron Connector	

Note: The horizontal bar on the Iron Connector should be perpendicular to the seam of the table panel splice

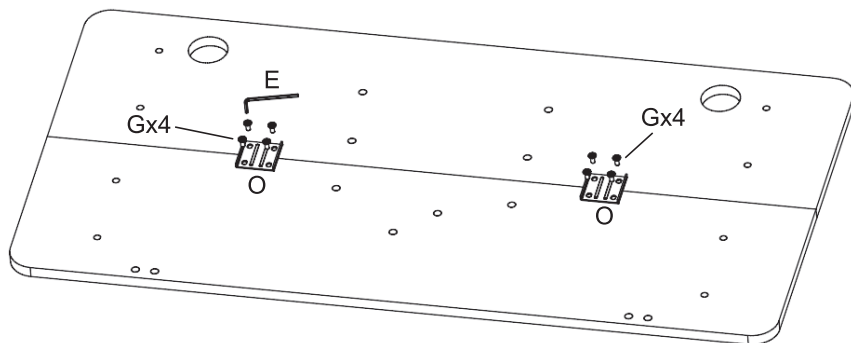

3

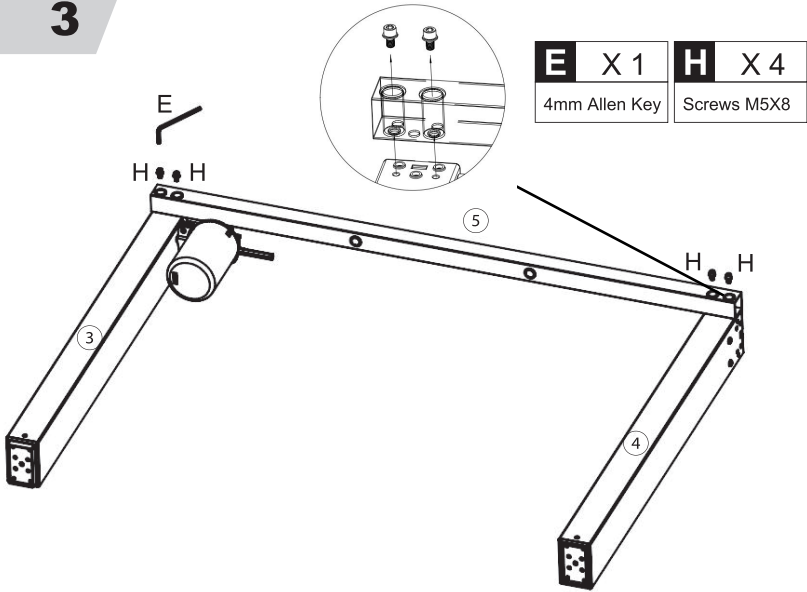

4

Install the another ⑤ -Support Beam on the other side in the same way as in step 3.

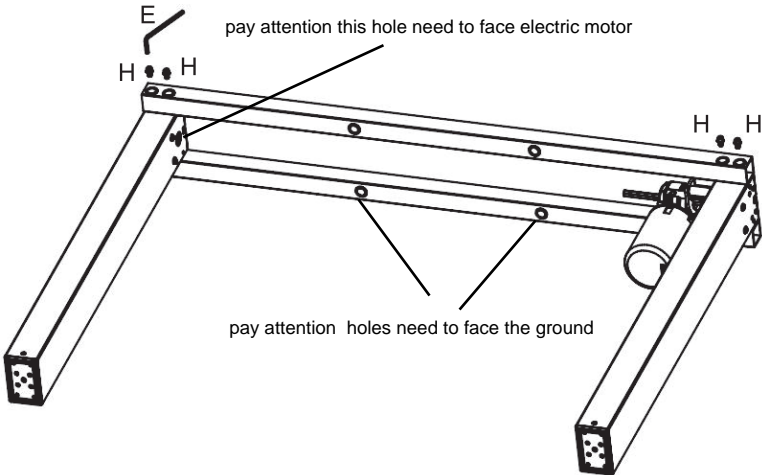

5

C X 4	E X 1	I X 8
Leveling Studs	4mm Allen Key	Screws M6X30

Note: Two more screws in the accessory bag

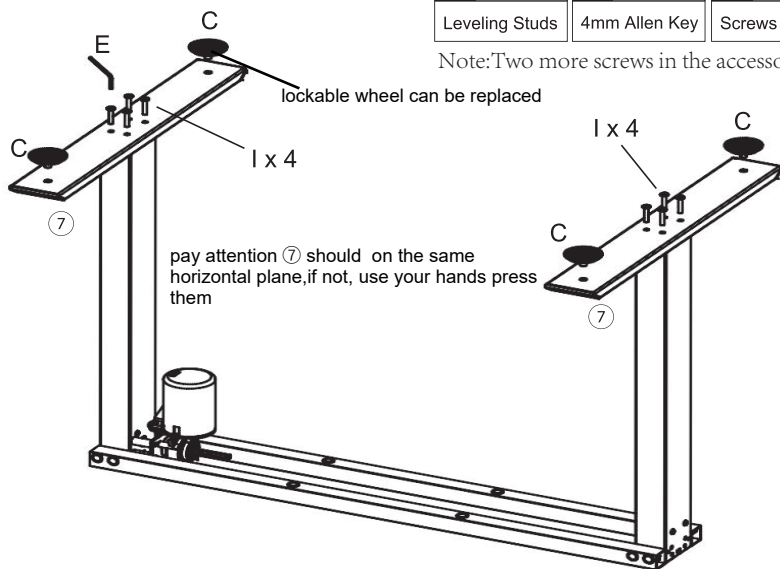

6

M X 2	E X 1	H X 4
Hook	4mm Allen Key	Screws M5X8

Stand the desk up and install ⑥ -Side Brackets. At the same time, hooks can be installed together with the brackets, in any one of the four holes according to personal habits.

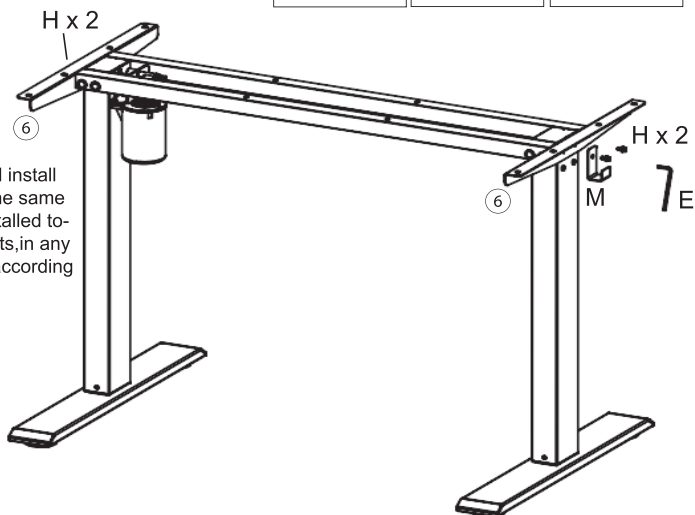

7

Install the ⑧-Sync Rod and tighten the two screws at the both end of Sync Rod.

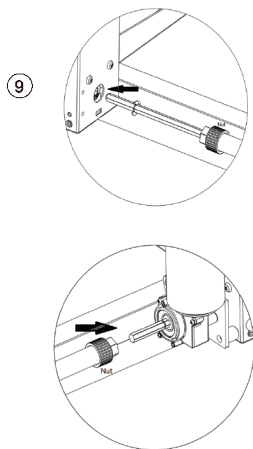
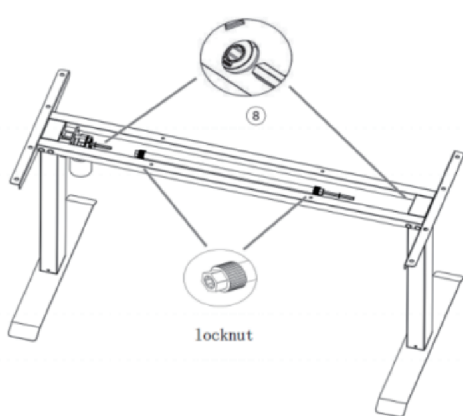

8

Install the frame on the desktop. Then install the K -AC Adapter.

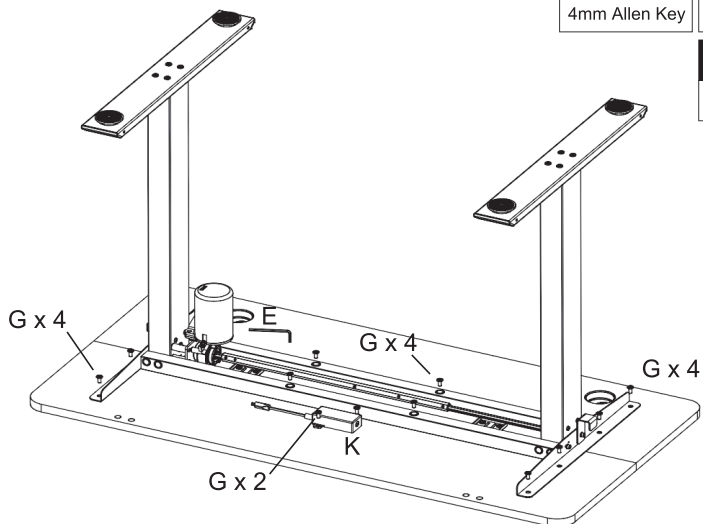

E X 1	G X 14
4mm Allen Key	Screws M6X12
K X 1	
	AC Adapter

9

Install B -Controller and L -Wire Basket on the desktop.

E	X 1
4mm Allen Key	

B	X 1
Controller	

L	X 1
Wire Basket	

G	X 4
Screws M6x12	

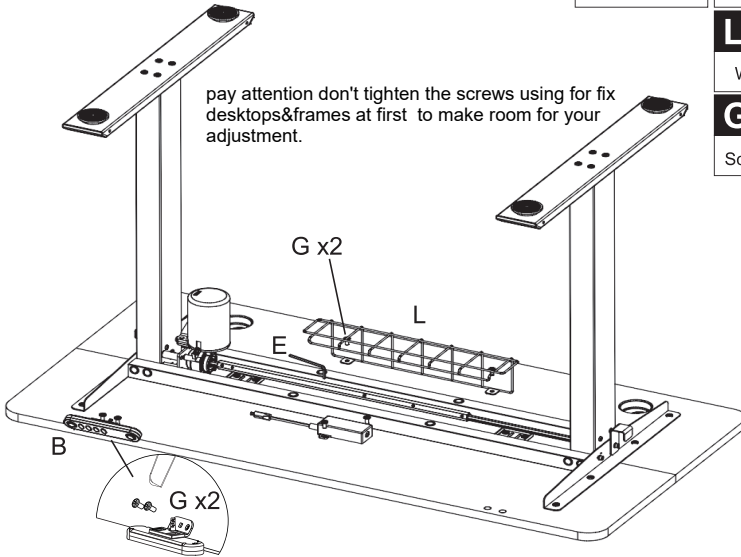

10

Stand the desk up and press the outlet box firmly into the desk.

N	X 2
Outlet Box x2	

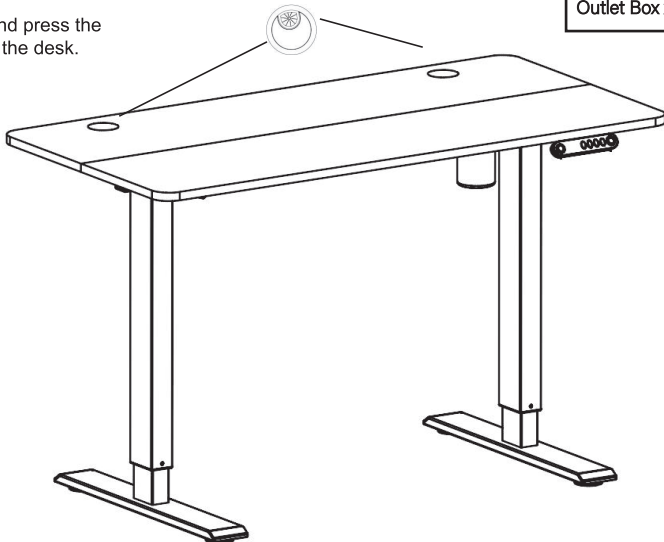

11

Connect Controller, AC Adapter, Power Cable and Left Leg.

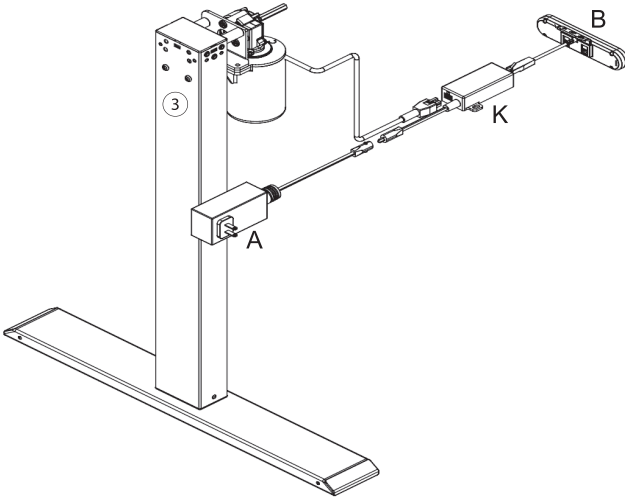

Use D -Wire Clips to tidy up the wires.

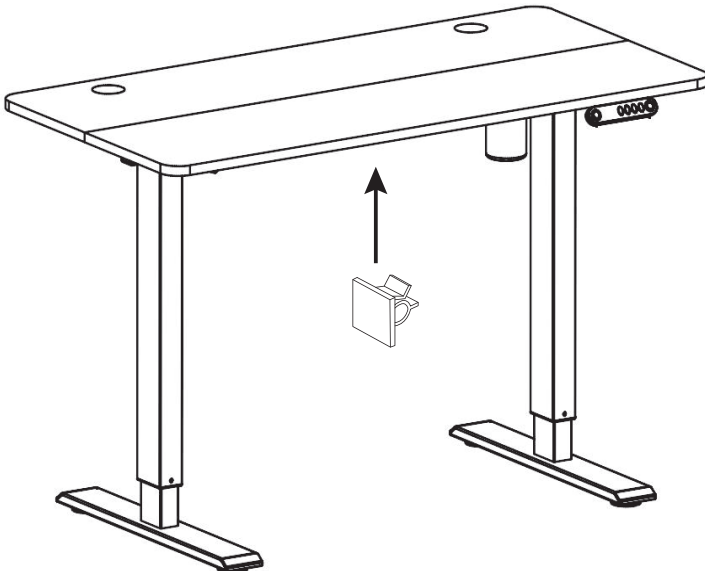

CONTROLLER INSTRUCTION

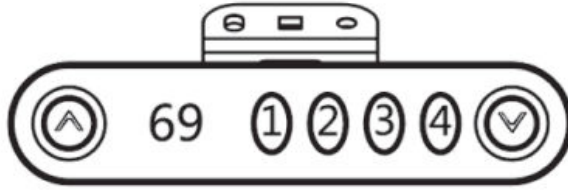

RESET Setting	Method 1: Press and hold “^” and “V” buttons on the handset at the same time for 4 seconds, it shows “000”, until you hear the beep release the buttons. The desk will go down slowly automatically (it will have a rebound and rise about 5cm) until it shows “69” and you hear the beep, the reset is successful.
Height Adjustment	Up: Press Up “^” . Down: Press Down “V” .
Switch Display	Press 2 times “V” when the desk at the lowest position to switch cm to inch.
Memory Height	Press and hold any of memory buttons (1, 2, 3 or 4) until you hear a beep. Release the button, and this position height will be stored in memory. When the working height of memory needs to be used, press the memory position button and the desk will automatically adjust to the memory height. Note: This standing desk has 4 different height memories. The memory positions stored are still valid after power off. You can use the up and down buttons to adjust the standing desk to the height you need to work.

Trouble shooting Guide:

If your standing desk does not work properly, you may need to reset it.

If any error codes appear, you need to reset it.

If it still does not work after the reset, please contact us for more help.

Maintenance and Consideration:

1. During daily maintenance, use a clean soft cloth to remove surface dust. Do not use a wet cloth or hard material to wipe the surface of the table.
2. Avoid contacting the surface with acid-based chemicals.
3. For slight scratches, gently wipe with a soft cloth, you can smooth out scratches. Avoid attaching tape directly to the outer surface of the metal feet to prevent paint from peeling.