

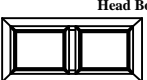

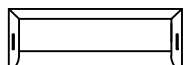



ASSEMBLY INSTRUCTIONS

DESCRIPTION : QUEEN HB / FE
QUEEN RAIL

No	Part List	Qty.
	Head Board	
A		1 PC
	Foot Board	
B		1 PC
	(L/R) Head Board Leg	
C		2 PCS
	Side Rail	
D		2 PCS
	Bottom Rail	
E		3 PCS
	Bottom Rail Support	
F		3 PCS
No	Hardware List	Qty
G	CSK SCREW M4 x 32MM 	6 PCS
H	JCBC BOLT M6 x 35MM 	6 PCS
I	ALLEN WRENCH M4 	1 PC

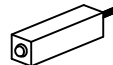
STEP 1 : Attach Head Board Side Leg (C) to Head Board (A) and tighten with JCBC (H) use Allen Wrench (I).

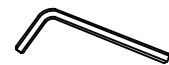
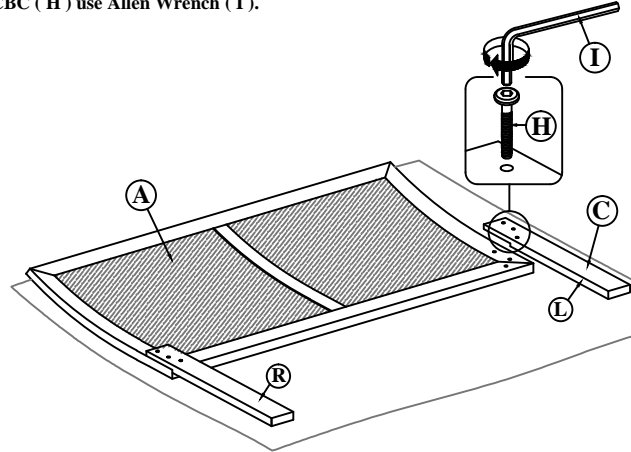

STEP 2 : Attach Side Rail (D) to Head Board (A) Closely and push down to fit it. Repeat the same step to fitting the Foot Board (B). Secure the Side Rail (D) to the Head Board and Foot Board using hammer and protect with cloth. Repeat the procedure until the Head Board and Foot Board not shaking easily. (NOTE : THE CLOTH MUST THICK ENOUGH TO PROTECT THE SIDE RAIL FROM SPLITTING).

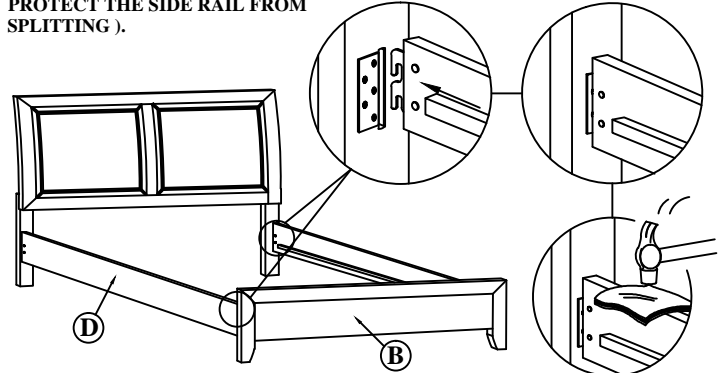

STEP 3 : Attach the Bottom Rail Support (F) to Bottom Rail (E) as picture shown. Fix the assembled Bottom Rail (E) to attach Side Rail (D). Lastly, tighten the Bottom Rail (E) with CSK screw (G), loosen and tighten the adjuster for stability of bed.
(NOTE: THE SETUP MUST DONE AT THE DECIDED LOCATION FOR THE BED TO OBTAIN PERFECT STABILITY)

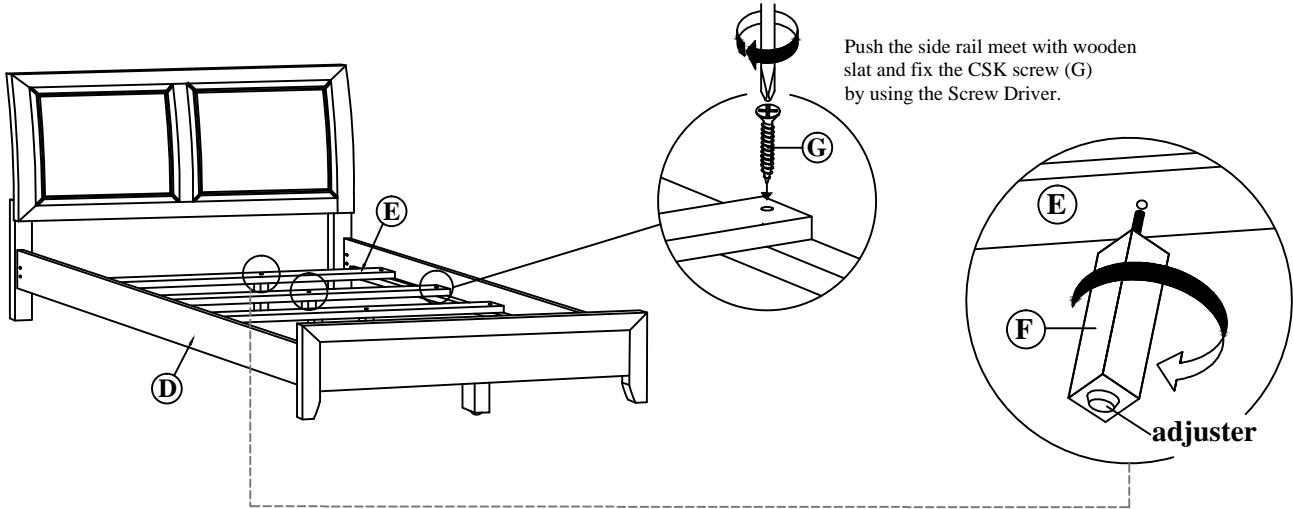

NOTE : SCREWS WILL BECOME LOOSE WITH USE AND OVER TIME WILL NEED TO BE TIGHTENED PERIODICALLY. CHECK TIGHTNESS OF ALL SCREW EVERY 6-8 WEEKS.
THANK YOU FOR PURCHASING THIS QUALITY PRODUCT. BE SURE TO CHECK ALL PACKING MATERIAL CAREFULLY FOR SMALL PARTS WHICH MAY HAVE BECOME LOOSEN INSIDE THE CARTON DURING SHIPMENT.