

ASSEMBLY INSTRUCTION

3PC PACK COUNTER HEIGHT SET WITH FAUX MARBLE TOP

A Table Top

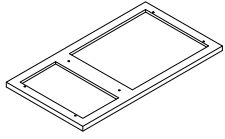

1PC

B Left Side Frame

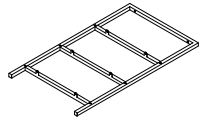

1PC

C Middle Frame

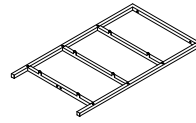

1PC

D Right Side Frame

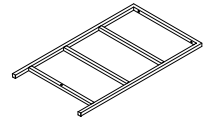

1PC

E Table Stretcher

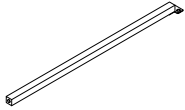

1PC

F Shelf Rail

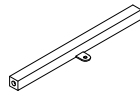

6PCS

G Shelf Panel

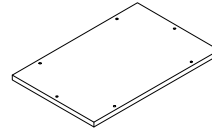

3PCS

H Seat Cushion

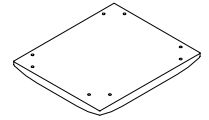

2PCS

I Stool Side Frame

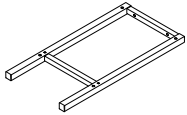

4PCS

J Stool Top Stretcher

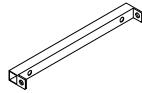

4PCS

K Stool Bottom Stretcher

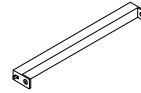

4PCS

L Bolt
1/4"*32mm



35PCS

M Bolt
1/4"*13mm



18PCS

N Bolt
2/13"*13mm



18PCS

O Ratchet Tool
5mm



1PC

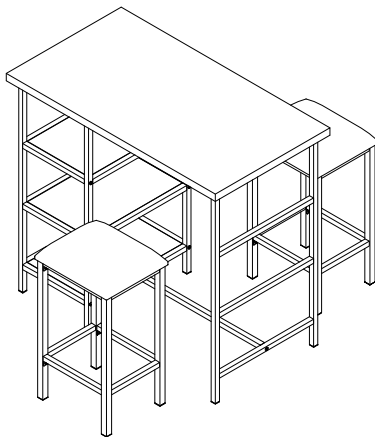

This page lists all the contents included in the box. Please take the time to identify the hardware as well as the individual components to this product. As you unpack and prepare for assembly, place the contents on a carpeted or padded area to protect them from damage.

How to Use the Ratchet Tool (O)

1. Before assembling the furniture, please adjust the lock as needed.

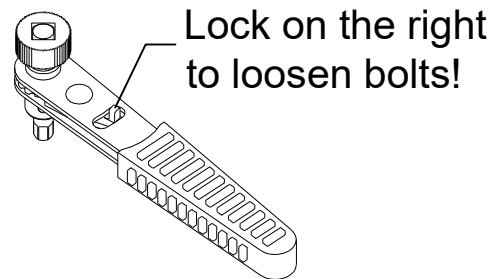
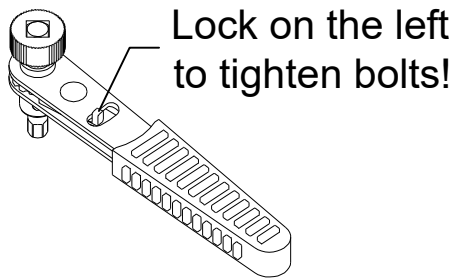

2. Tighten or loosen bolts.

- **Tighten bolts:** Locate the turncap and rotate it clockwise to screw the bolt quickly until it cannot be rotated any more. Then start rotating the handle clockwise to finalize tightening the bolt.

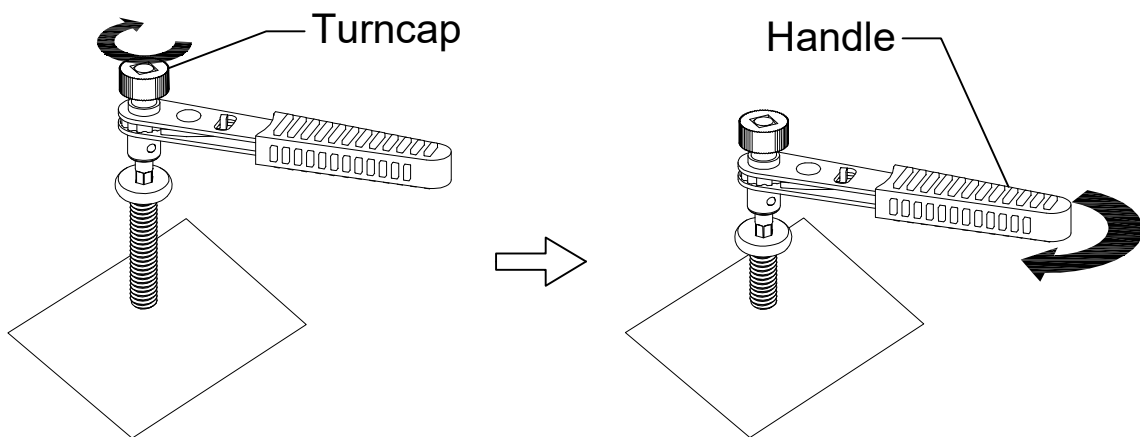

- **Loosen bolts:** Rotate the handle counterclockwise to loosen the bolt. Then continue rotating the turncap in the same direction to remove the bolt completely.

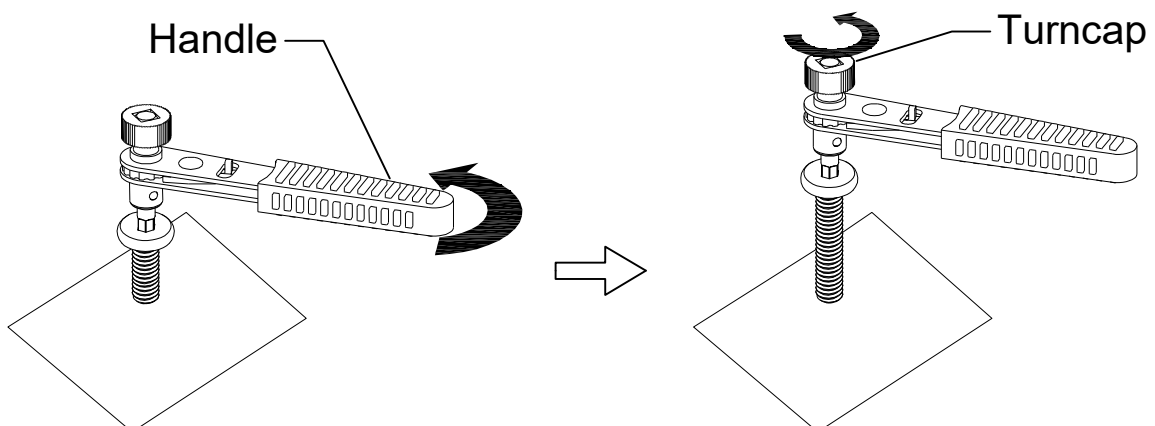

1

Attach Left Side Frame (B), Right Side Frame (D) and Middle Frame (C) to the Table Top (A), insert the Bolt (L), turn the Ratchet Tool (O) to tighten them.

NOTE: Brackets on Left Side Frame (B) and Middle Frame (C) must be oriented towards the opposite direction as shown.

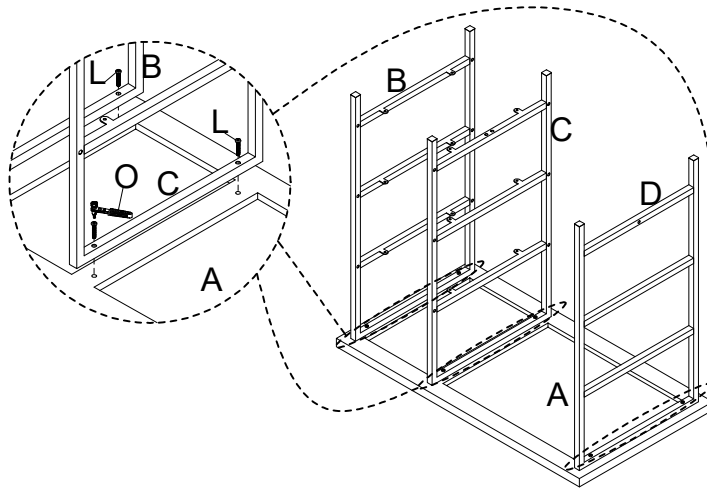
**2**

Attach the Table Stretcher (E) to the Middle Frame (C) and Right Side Frame (D), insert the Bolt (M) and Bolt (L), turn the Ratchet Tool (O) to tighten them.

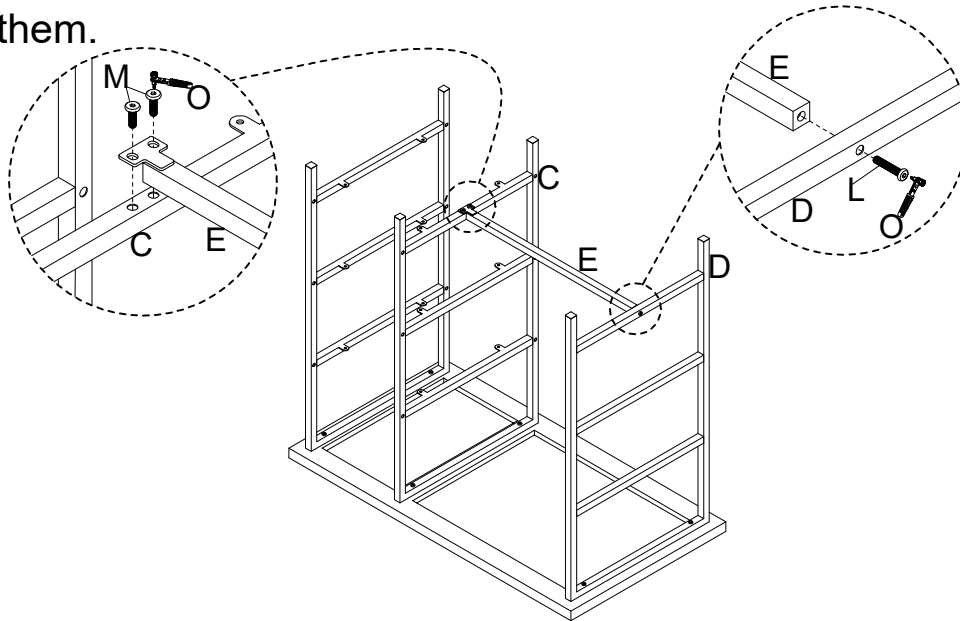
**3**

Attach the Shelf Rail (F) to the Left Side Frame (B) and Middle Frame (C), insert the Bolt (L), turn the Ratchet Tool (O) to tighten them.

NOTE: Brackets on Shelf Rail (F) must be oriented towards the inside of the assembly.

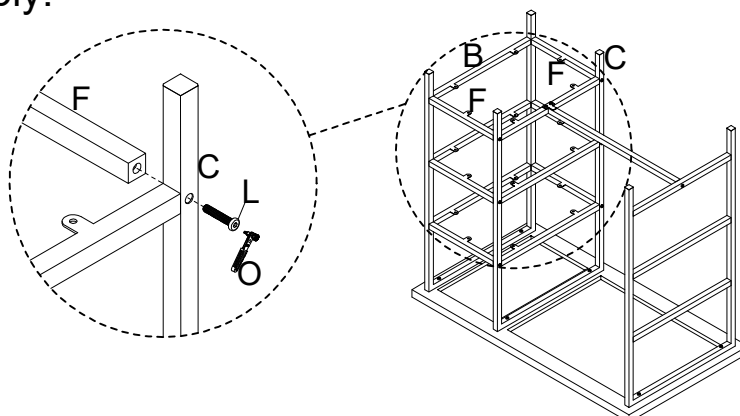

4 Attach the Shelf Panel (G) to the assembled shelf frame, insert the Bolt (N), turn the Screwdriver to tighten them.

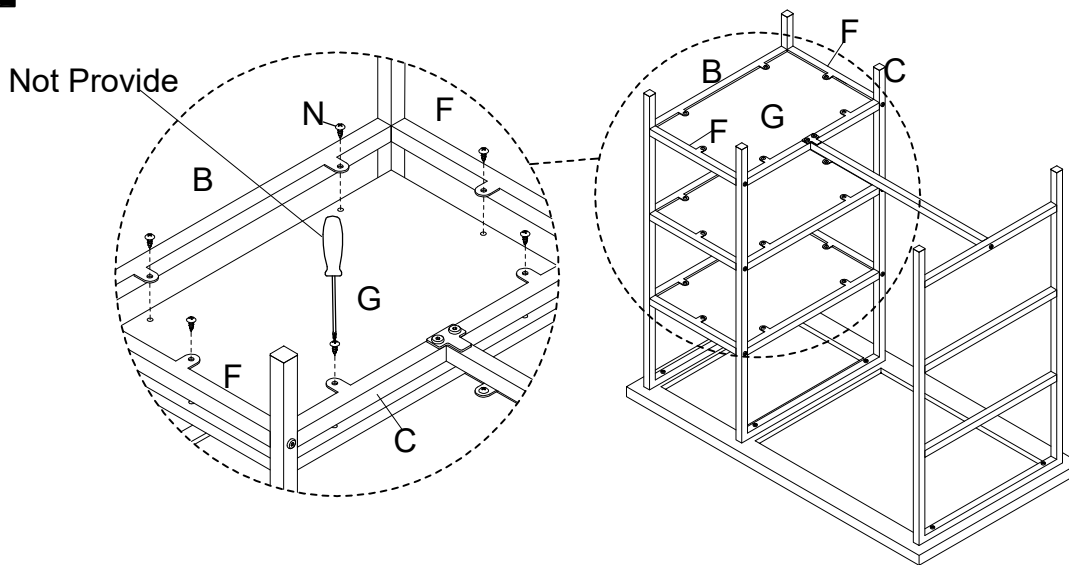

5 Attach the Stool Top Stretcher (J) and Stool Bottom Stretcher (K) to the Stool Side Frame (I), insert the Bolt (M), turn the Ratchet Tool (O) to tighten them.

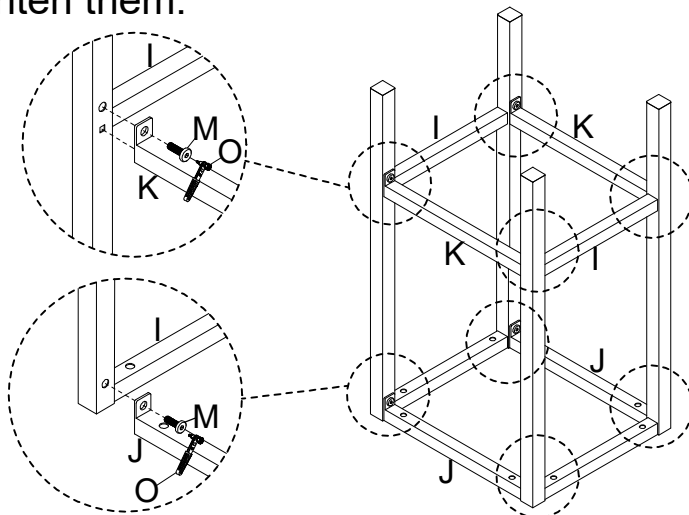

Take the Ratchet Tool, and turn the bolts until the legs are secure. **DO NOT TIGHTEN COMPLETELY.** Stop when you feel you are adding force to tighten the bolts.

6 Attach the Seat Cushion (H) to the assembled stool frame, insert the Bolt (L), turn the Ratchet Tool (O) to tighten them.

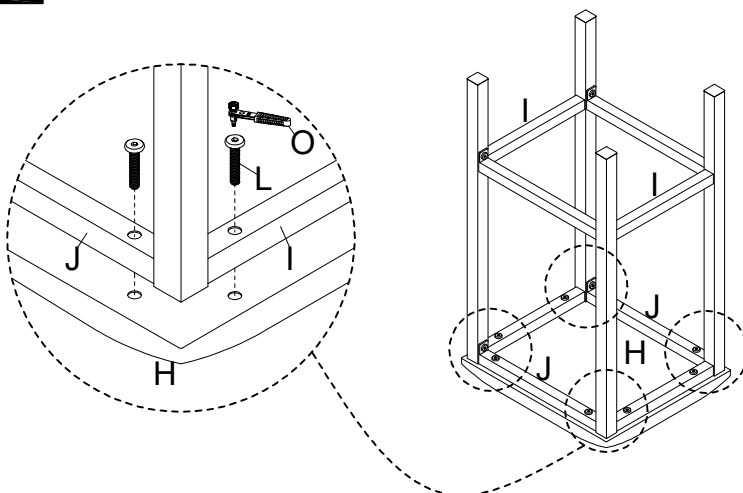

Stand stool up on an even surface and check that it is balanced. If there is a slight wobble, apply downward pressure in the corner where a leg is uneven. Keeping pressure in that corner, tighten all bolts. If balanced, apply downward pressure evenly in the center and tighten all bolts. Do not over-tighten beyond hole depth.

Helpful Tip:
Instead of applying downward pressure while reaching under to tighten bolts, have someone sit in the stool while you tighten the bolts.

Cleaning & Care

Treat surface with care. Surface is resistant to scratches but is not scratch resistant. Clean surfaces with a dry or damp soft cloth. Do not use abrasive cleaners. Hardware may loosen over time. Periodically check that all connections are tight.