

WARRANTY

We strive to offer high-quality products, and we also try our best to satisfy each and every customer that orders from us with product or service as needed.

Each customer must provide a record of their order such as the order number, or item receipt for any items that are out of the warranty period you may also still receive replacement parts by purchasing them with our company if they are available.

**Are you having difficulty
with assembly? Missing parts?**

Please contact us : info@firstopintl.com

telephone No.:5627813327

send email with your order No. to

**For return, please check the return policy with
the retailer or market place you bought from.**

Appreciate your purchasing from us.

Pop up your life by our furniture !

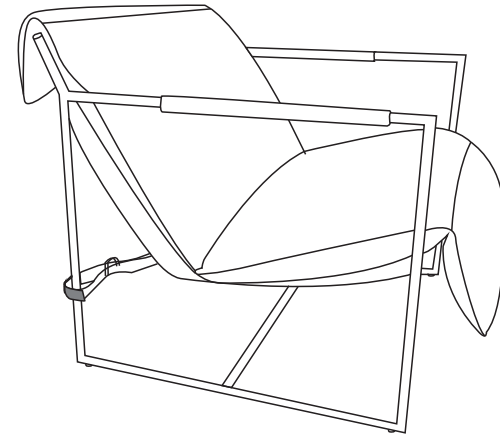
The logo for Wixé, featuring the word "wixé" in a bold, lowercase, sans-serif font. The letter "i" is stylized with a grey dot and a vertical grey bar extending downwards.

ITEM NO. CH0038

NOTE:

This brochure contains IMPORTANT safety info. Please read and keep for future reference.

MAINTAINANCE AND WARNING

- Keep furniture away from heat and fire.
- Keep furniture away from sharp objects.
- Do not clean furniture with harsh cleansers or polish. Do not use detergents, Solvents, abrasives, spray packs or leather cleaner. Use non-color mild soap with warm water clean spills(Mix 1:10 soap to water)
- Do not place furniture under direct sunlight, material will possibly fade over time.
- Do not jump or strike on the furniture.
- Do not write on furniture without a padded barrier to protect the surface.
- Not for commercial use, For residential use only.



Weight Limitation

400LBS

PARTS LIST

Ax1

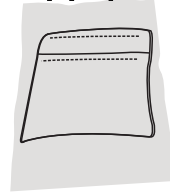

Back Cushion

Bx1

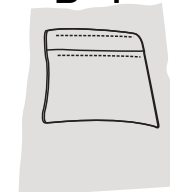

Seat Cushion

Cx1

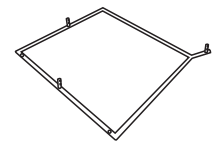

Right Armrest

Dx1

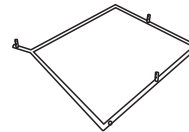

Left Armrest

Ex3



Metal Bars

Fx1

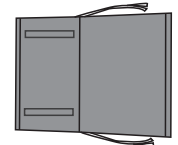

Cushion Support

Gx2

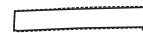

Armrest Covers

HARDWARE and TOOL LIST

① x 12



M6* 10MM
Bolt

② x 1



Allen key

SPARE

③ x 1



Plastic foot pad

Be sure to check all packing materia fit the packing list. Carefully for small parts, which may have come loose inside the carton during shipment.

ASSEMBLY INSTRUCTIONS

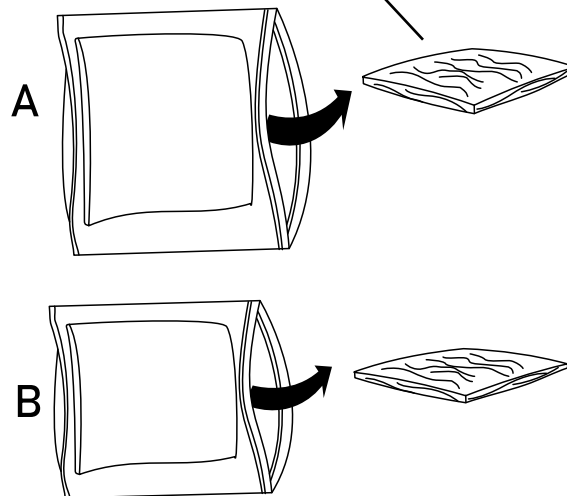
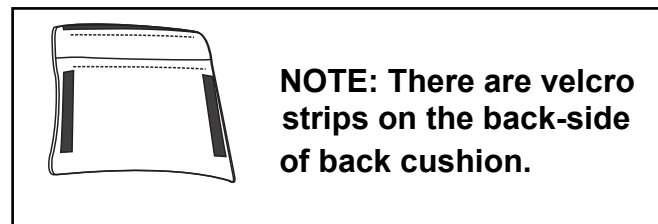

STEP 1: Take the back cushion (A) and seat cushion (B) from the vacuum bags, let them expand for about 24 hours.

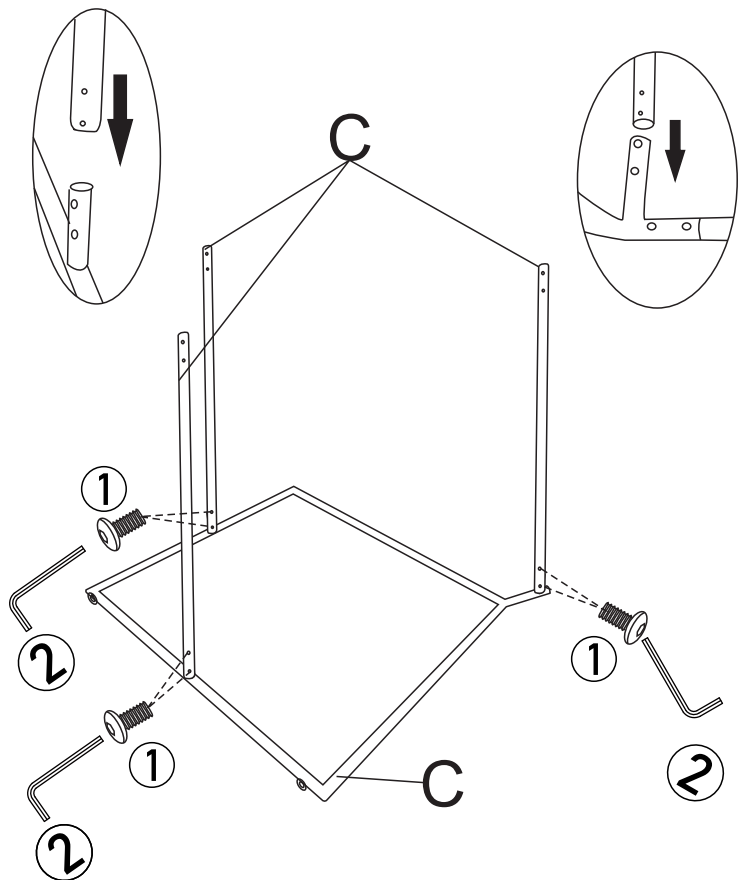

NOTE: When screw the bolts, don't tighten completely, but only for 50%.

STEP 2: Place the right armrest (C) on clean padded surface. Connect the metal bars (E) and armrest (C) by aligning the settled holes. Tighten with bolts ① and allen key ②.

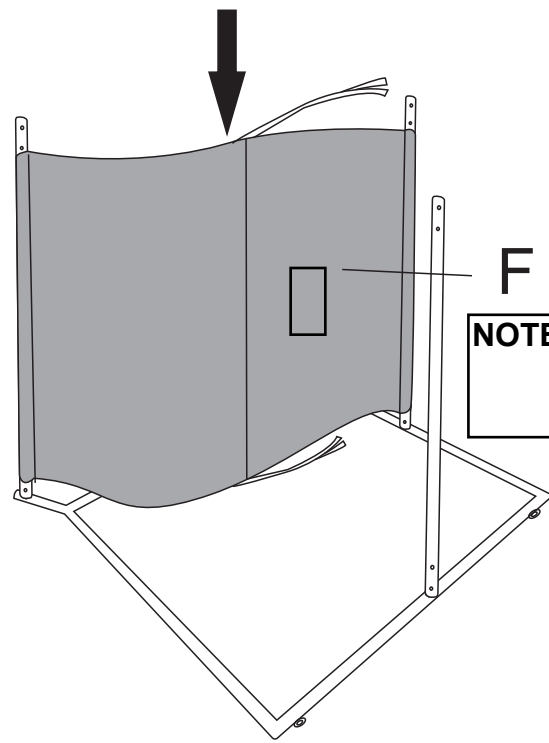
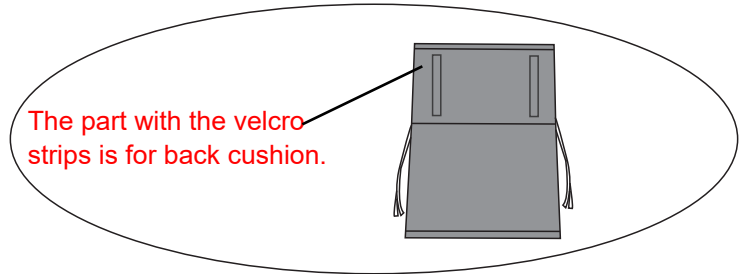

NOTE: This side with law label is under the surface.

STEP 3: Turn the assembled part on last step aside, insert the metal bars (E) into the long fabric tubes on cushion support (F).

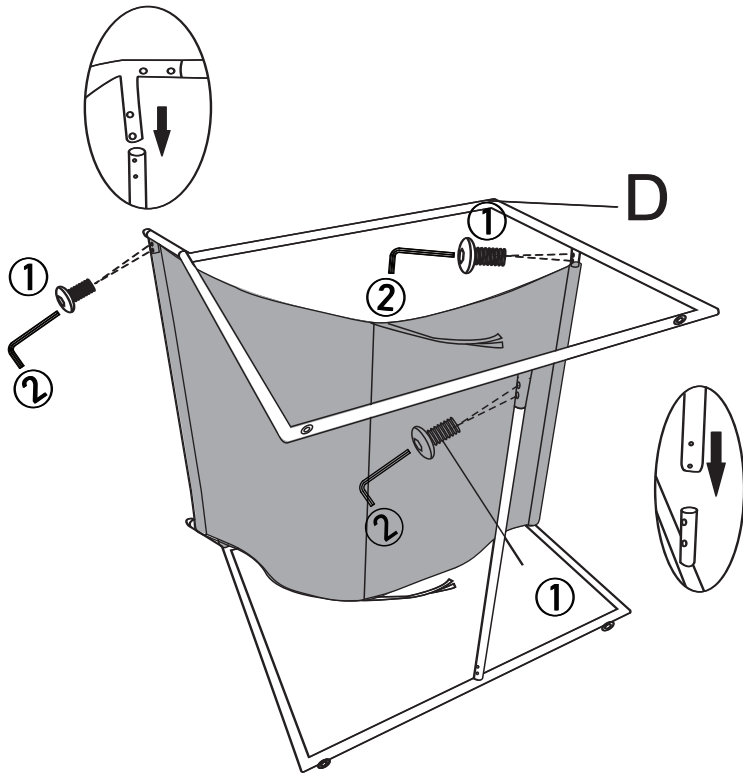

NOTE: When all bolts are fixed into the settled holes, tighten all of them with allen key completely.

STEP 4: Connect the metal bars (E) and left armrest (D) by aligning the settled holes. Tighten with bolts ① and allen key ②.

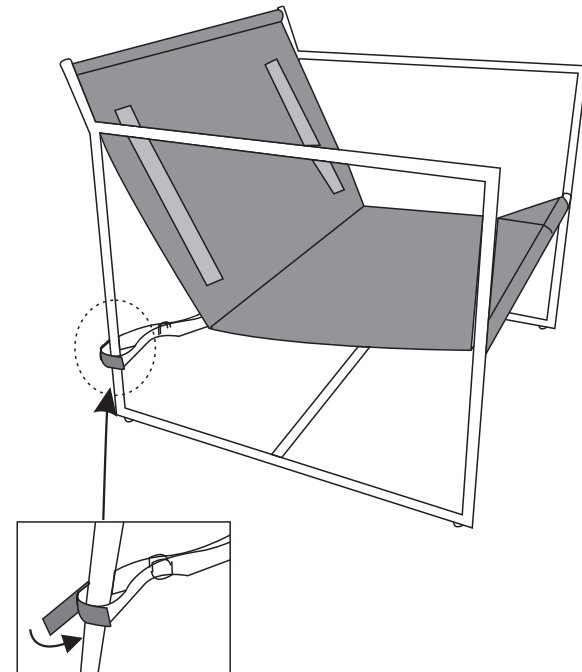

STEP 5: Connect the string on the cushion support (F) with the rear metal tubes of armrests. Tighten the string in circles and stick the both parts of velcro as instruction.

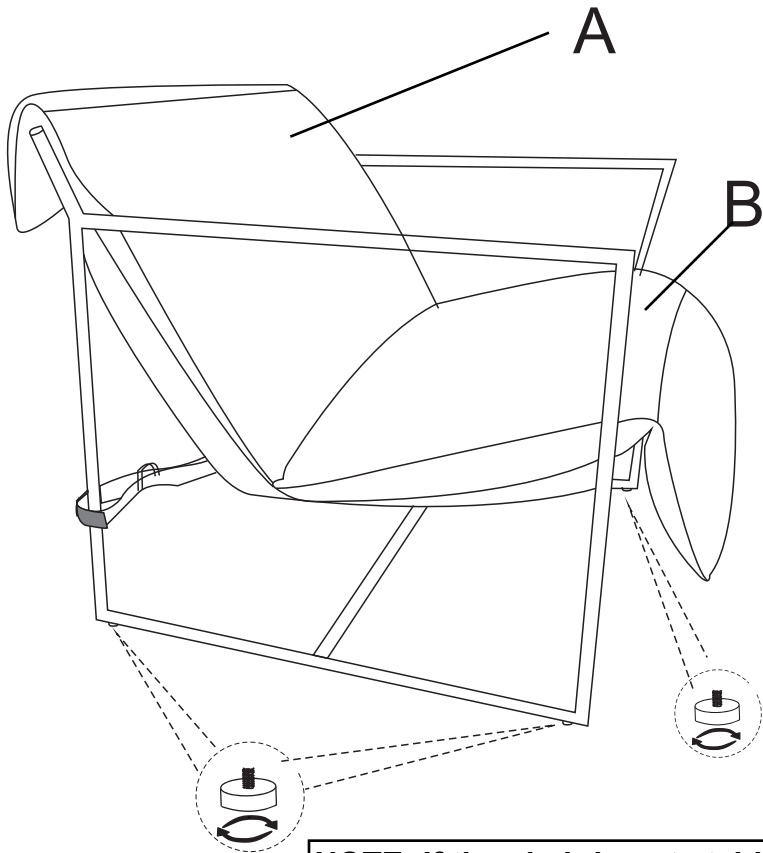

NOTE: If the chair is not stable after assembly, please adjust the plastic foot pads on the bottom.

STEP 6: Put on the seat cushion (A) and back cushion (B) accordingly. Align the velcro strips on back cushion and cushion support.

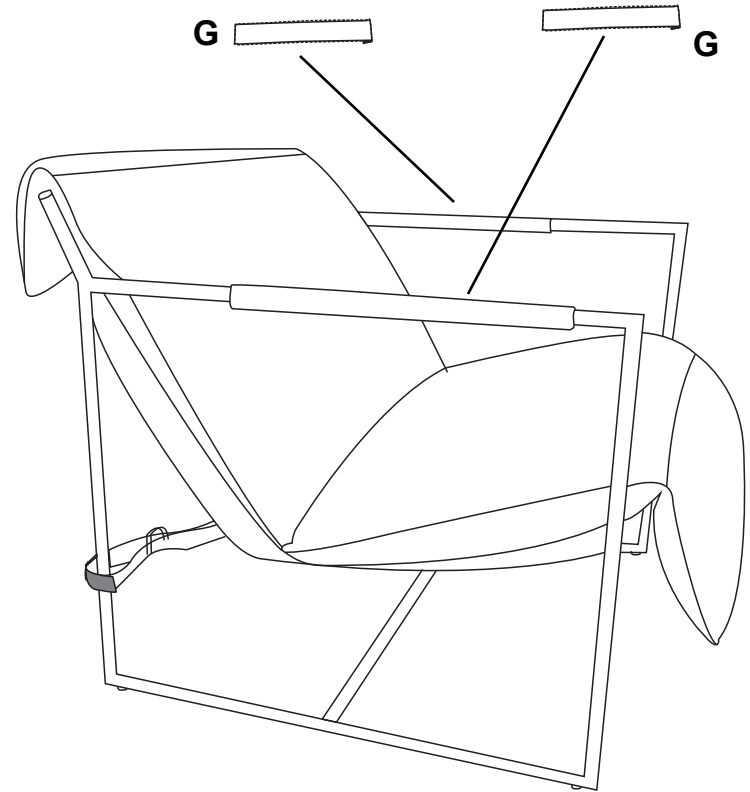

STEP 7: Take out the armrest covers (G) and zip it on the armrests as instruction. Assembly is completed.