



Item # 45-6066

3-in-1 Swivel Table

84
Inch



3

BILLIARDS
AIR HOCKEY
TABLE TENNIS

**IN ONE
GAME TABLE**



Limited 90-Day Triumph Sports USA, Inc. Warranty

All Triumph Sports USA, Inc. (TSU) games have a limited 90-day from date of purchase warranty. This warrants the retail purchaser for any TSU game purchased to be free from any defect in materials and construction for 90 days from the date of purchase. The only exceptions to the warranty include main frames, tabletops, playing surfaces, batteries or tools. Damaged main frames, tabletops, playing surfaces need to be returned to the store as we are unable to replace these parts. Normal play wear and usage is not covered under the warranty, nor is wear or damage due to improper use of the TSU game. This will void any and all TSU warranties.

A PURCHASE RECEIPT (or other proof of purchase date) will be required before any warranty service is initiated. All requests for warranty service can be submitted by email, in writing or by contacting our Customer Service Department at: 1-866-815-4173 or email us at csr@triumphsportsusa.com.

Warnings



WARNING: Choking Hazard--Toy contains small balls and/or small parts. Not for children under 3 years of age.



WARNING: Rotating the game should be done under adult supervision. Rotating table may cause a pinching hazard for young children and pets. Please exercise caution. At least two adults are needed to put this game table together.

Be sure to check out all the exciting games  has to offer.

Visit our web site at:

www.triumphsportsusa.com



BILLIARDS



DARTS



GAME TABLES



CASINO



OUTDOOR GAMES



DARTBOARDS

Triumph Sports USA
11327 W Lincoln Ave.
West Allis, WI 53227

www.triumphsportsusa.com

©2013 Triumph Sports USA. All Rights Reserved.

IMPORTANT SAFETY INSTRUCTIONS

Read all instructions











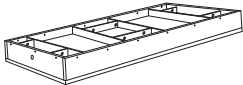
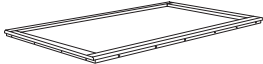



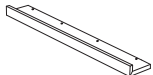

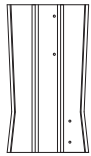



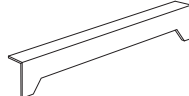
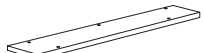

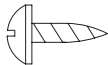
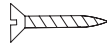
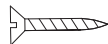
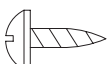

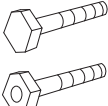
1. Read all instructions-All the safety and operating instructions should be read carefully before this hockey game is played.
2. Caution-This is not a toy and is intended for use by or under the supervision of adults. Adults should review safety guidelines with children to avoid possible risk of electric shock or other injuries.
3. Power sources-This hockey game should be operated only from 110-120V A.C., 60 cycle current as indicated on the identification label. If you are not sure of the type of power supply to your home, consult your appliance dealer or local power company.
4. Power cord protection-Power cord should be routed so that it is not likely to be walked on or pinched by items placed upon or against it. Pay particular attention to cords at plugs, convenience receptacles, and the point of exit from the game.
5. Overloading-Do not overload wall outlets and extension cords as this can result in a risk of fire or electric shock.
6. Object and liquid entry-Never push objects of any kind into this game through openings as they may touch dangerous voltage points or short-out parts which could result in a fire or electric shock. Never spill liquid of any kind on the game.
7. Ventilation-Openings in the game are provided for the exhaust air to create a cushion effect. The openings on the air blower are for the intake air. Keep clear of the air blower when it is on. Do not put hand or other objects near the intake openings. To ensure reliable operation of the game and protect it from overheating these openings must not be blocked or covered.
8. Damage requiring service-Unplug the game from the wall outlet.
Do not attempt to service the blower yourself as opening or removing covers may expose you to dangerous voltage or other hazards. Refer servicing to qualified service personnel under the following conditions.
 - A. When the power supply cord or plug is damaged.
 - B. If liquid has spilled, or objects have fallen into the blower.
 - C. When the air blower exhibits a distinct change in performance e.g. abnormal noise, this indicates a need for service.
9. Grounding or Polarization-This game is equipped with a polarized alternating current line plug (a plug having one blade wider than the other). This plug will fit into the power outlet only one way. This is a safety feature. If you are unable to insert the plug fully into the outlet, try reversing the plug. If the plug should still fail to fit, contact your electrician to replace your obsolete outlet. Do not defeat the safety purpose of the polarized plug.
10. CAUTION-ELECTRICALLY OPERATED PRODUCT-Not recommended for children under 8 years of age. As with all electrical products, precautions should be observed during handling and use to reduce the risk of electric shock.
11. We recommend that the game be periodically examined for conditions that may result in the risk of fire, electrical shock, or injury to persons. In the event such conditions exist, the game should not be used until properly repaired.
12. **RISK OF FIRE, ELECTRIC SHOCK, OR INJURY TO PERSONS**
WARNING-When using electric appliances, basic precautions should always be followed, including the following:
 - A) Read all the instructions before using the appliances.
 - B) To reduce the risk of injury, close supervision is necessary when an appliance is used near children.
 - C) Do not contact moving parts.
 - D) Only use attachment recommended or sold by the manufacturer.
 - E) Do not use outdoors.
 - F) For a cord-connected appliance, the following shall be included:
 - To disconnect, turn all controls to the off position, then remove plug from outlet.
 - Do not unplug by pulling on cord. To unplug, grasp the plug, not the cord.
 - Unplug from outlet when not in use and before servicing or cleaning.
 - Do not operate any appliance with a damaged cord or plug, or after the appliance malfunctions or is dropped or damaged in any manner. Return appliance to the nearest authorized service facility for examination, repair, or electrical or mechanical adjustment.
13. To reduce the risk of electric shock, this appliance has a polarized plug (one blade is wider than the other). This plug will fit in a polarized outlet only one way. If the plug does not fit fully in the outlet, reverse the plug. If it still does not fit, contact a qualified electrician to install the proper outlet. Do not change the plug in any way.

SAVE THESE INSTRUCTIONS



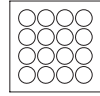

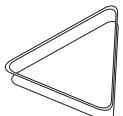

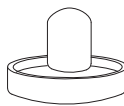

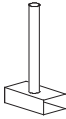
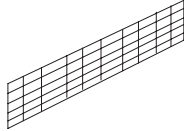

WARNING: To Reduce The Risk Of Fire Or Electric Shock, Do Not Use This Fan With Any Solid-State Speed Control Device.

For Household use only.

Parts List

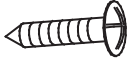
<p>1#</p>  <p>Cabinet-Billiards 1 Piece</p>	<p>2#</p>  <p>Cabinet-Hockey 1 Piece</p>	<p>3#</p>  <p>Leg Pedestal 2 Pieces</p>	<p>4#</p>  <p>Catcher Box 2 Pieces</p>	<p>5#</p>  <p>Lock Pin 4 Pieces</p>
<p>6#</p>  <p>Ball Below Board-A 2 Pieces</p>	<p>7#</p>  <p>Ball Below Board-B 2 Pieces</p>	<p>8#</p>  <p>Steel Bracket 4 Pieces</p>	<p>9#</p>  <p>Right Leg 2 Pieces</p>	<p>10#</p>  <p>Left Leg 2 Pieces</p>
<p>11#</p>  <p>Leg Brace 4 Pieces</p>	<p>12#</p>  <p>Leg Base 4 Pieces</p>	<p>13#</p>  <p>Apron-End Board 4 Pieces</p>	<p>14#</p>  <p>Outside Rail 2 Pieces</p>	<p>15#</p>  <p>Top Side Panel 2 Pieces</p>
<p>16#</p>  <p>Tennis Surface-A 2 Pieces</p>	<p>17#</p>  <p>Tennis Surface-B 1 Piece</p>	<p>18#</p>  <p>WP4*1-1/4" Screw 20 Pieces</p>	<p>19#</p>  <p>F4*3/4" Screw 16 Pieces</p>	<p>20#</p>  <p>F4*1-3/4" Screw 74 Pieces</p>
<p>21#</p>  <p>T4*1/2" Screw 8 Pieces</p>	<p>22#</p>  <p>5/16*1-1/2" Allen key bolt 16 Pieces</p>	<p>23#</p>  <p>20mm Hex bolt (1 Piece Pre-assembled) 1 Pieces</p>	<p>24#</p>  <p>20mm Washer (2 Piece Pre-assembled) 2 Pieces</p>	<p>25#</p>  <p>5/16*19 mm Washer 16 Pieces</p>
<p>26#</p>  <p>Leg Leveler 4 Pieces</p>	<p>27#</p>  <p>Glue 1 Piece</p>	<p>28#</p>  <p>Wrench 1 Piece</p>	<p>29#</p>  <p>Tennis Top-Support 2 Pieces</p>	<p>30#</p>  <p>Billiard Balls 1 Set</p>
<p>31#</p>  <p>Cue Stick 2 Pieces</p>	<p>32#</p>  <p>Triangle 1 Piece</p>	<p>33#</p>  <p>Chalk 2 Pieces</p>	<p>34#</p>  <p>Brush 1 Piece</p>	<p>35#</p>  <p>Hockey Striker 2 Pieces</p>

Parts List

36#  Hockey Felt 2 Pieces	37#  Hockey Puck 2 Pieces	38#  Table Tennis Post 2 Pieces	39#  Table Tennis Net 1 Piece	40#  Table Tennis Bat 2 Pieces
41#  Table Tennis Ball 2 Pieces	42#  Plastic Strip 4 Pieces	43#  P3*3/4" Screw 8 Pieces	44#  End Panel Inner Cushion 4 Pieces	45#  20mm Plastic Washer (1 Piece Pre-assembled) 1 Piece
46#  Table Tennis Top Cushion 12 Pieces	47#  Allen Key 1 Piece			

Step 1

Route the power cord connector through the holes on the frame and connect the power cord together

Attach the Plastic Strip(#42) to the end of the Cabinet Billiard (#1) with screw (#43)

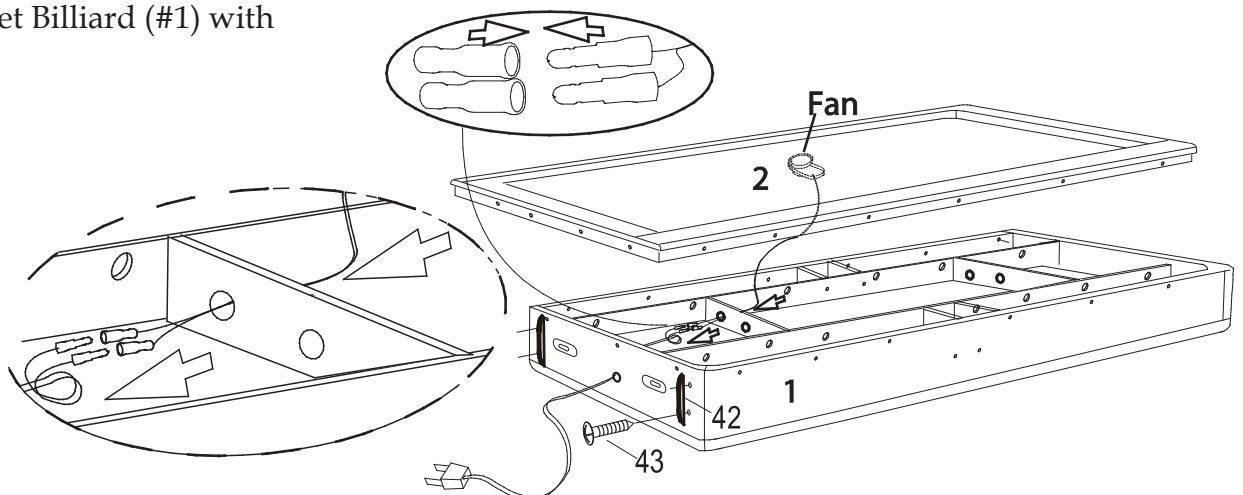

Step 2

Remove all components from the carton.
NOTE: Parts are packed inside the table top.
Remove the Hockey table surface (#2), inside the table top you will find all the parts needed to assemble your table. When all the parts are out of the table top, replace the Hockey table surface. Attach the pool table surface by using the screws (#18).

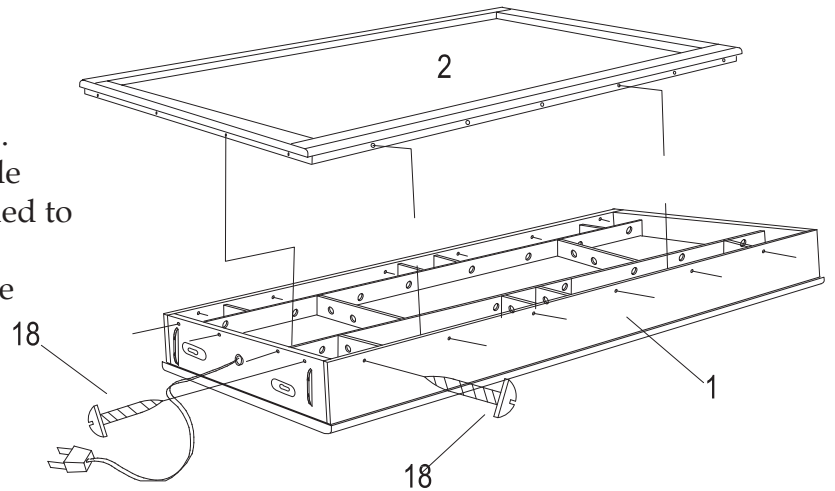

Step 3

FIG: 3A

Stick the end panel inner cushion (#43) to the each side of the end panel (#3).

FIG: 3B

Screw 2 lock pins (#5) into leg pedestal (#3) predrilled holes with screws (#19). Attach the catcher box (#4) with screws (#20) into predrilled holes.

FIG: 3C

Screw the ball below board-A (#6) to the leg pedestal (#3) using screws (#20) into predrilled holes.

FIG: 3D

Screw the steel bracket (#8) into the ball below board-B (#7) to the predrilled holes using screw (#21). Now attach the ball below board-B (#7) to the leg pedestal (#3) in the predrilled holes using screw (#20). Repeat these steps for the other end of the table.

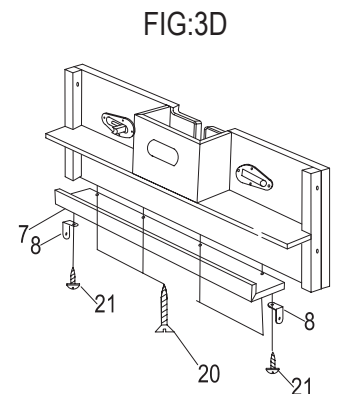
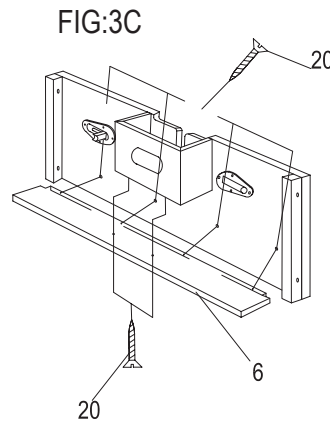
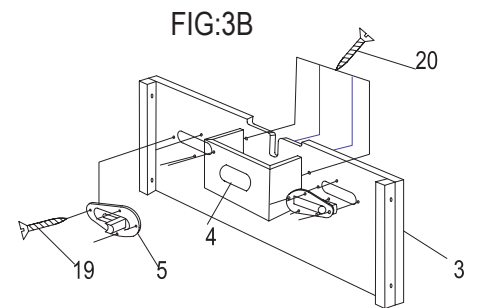
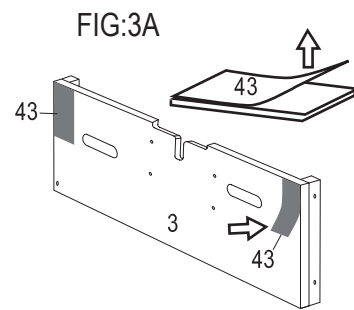

Step 4

Identify part (#12), leg base to FIG: 4C, add glue drops to both sides of image.

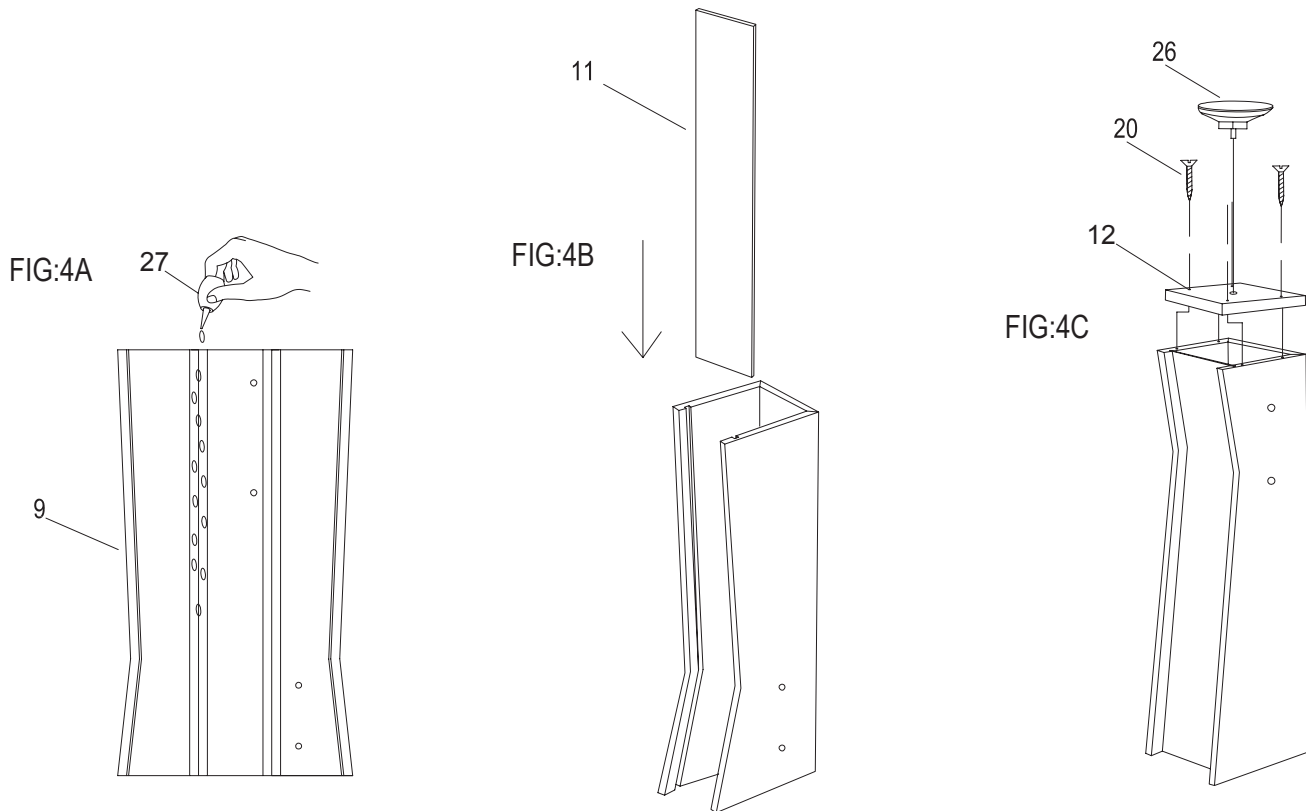

FIG: 4A

Assemble the legs (#9). Run a bead of glue (#27) in the grooves on the inside edges of the leg (#9).

FIG: 4B

Slide leg brace (#11) into glued grooves on leg (#9).

FIG: 4C

Screw leg base (#12) to bottom end of leg using screws (#20). Screw leg leveler (#26) into leg base (#12).

Repeat this step for all 4 legs, 2 of (#9) & 2 of (#10).

Step 5

Attach the leg pedestal (#3) to the legs (#9) & (#10). Align the screw holes on each side of the leg pedestal (#3) to each leg (#9 & #10) using Bolt(#22) with washer (#25). Now screw the steel bracket (#8) to the Predrilled hole in the leg using screw (#21).

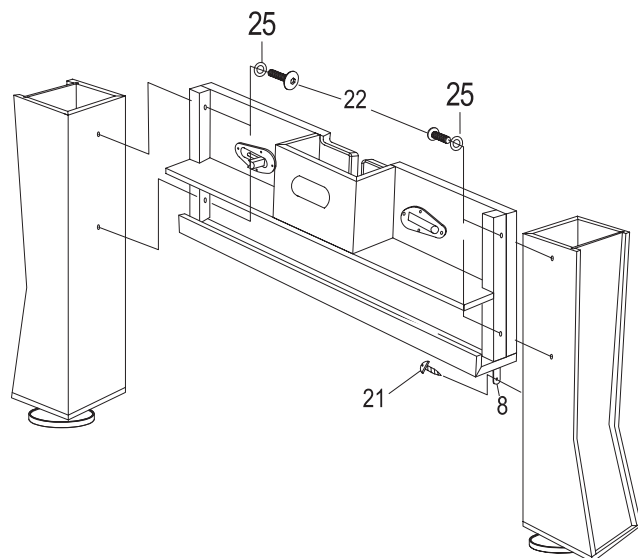

Step 6

Assemble the outside rails (#14) by screwing the apron-end board (#13) to each end of the outside rail (#14) with screw (#20).

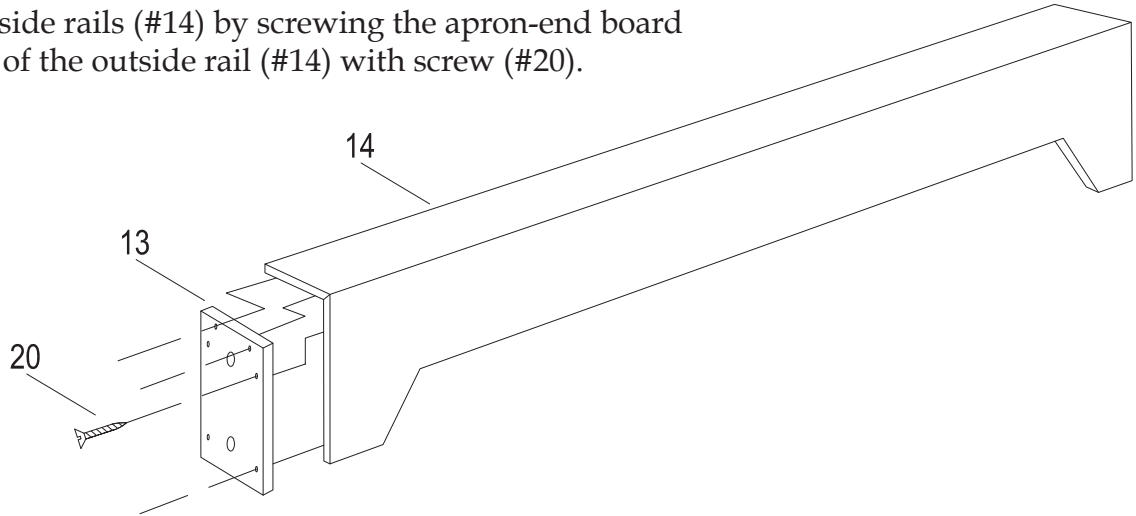

Step 7

With the help of another person attach the outside rails (#14) (flat side up) to the assembled leg pedestals by aligning the holes in the outside rails (#14) with the predrilled holes in the leg using screw (#22) with washer (#25).

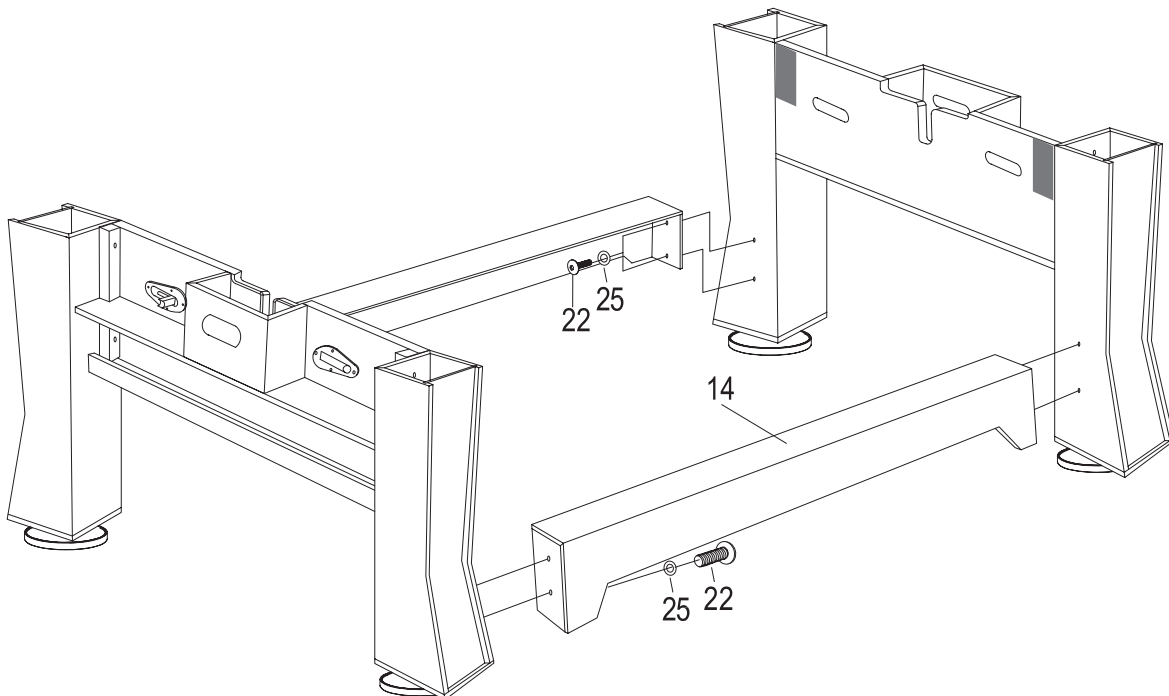

Step 8

Preparing the table top for mounting.

The threaded shaft in the cabinet-hockey (#1) cannot be removed, be sure to pull it out as far as possible, about 2 to 3 inches on the end with the electric plug. On the opposite end, slide ½" washer (#24) and ½" plastic washer (#25) onto the ½" hex bolt (#23). Insert the ½" hex bolt (#23) into the threaded shaft. Screw the bolt into the shaft leaving about 2 to 3 inches of the hex bolt exposed when the bolt is secured into the threaded shaft.

Attaching the table top to the base frame.

You are now ready to place the table top (#1) onto the base frame. With the help of a few friends, have two people on each side of the table top, and the other on the end to help guide the hex bolt (#23) into the slot on the on the leg pedestal. Once in place make sure the head of the hex bolt (#23) and the 20mm washer (#24) are sticking out past the leg panel. Make sure the plastic washer (#45) is against the cabinet-Billiard (#1) as it will act as the spacer for the table to rotate.

To securer the table top to the leg panel use the wrench (#28) provided. Tighten each of the 20mm hex bolts (#23) on each side of the leg panel towards each other, firmly tighten. This will lock the table top to the base frame, and still allow the table top to spin freely. When complete, engage all 4 lock pins.

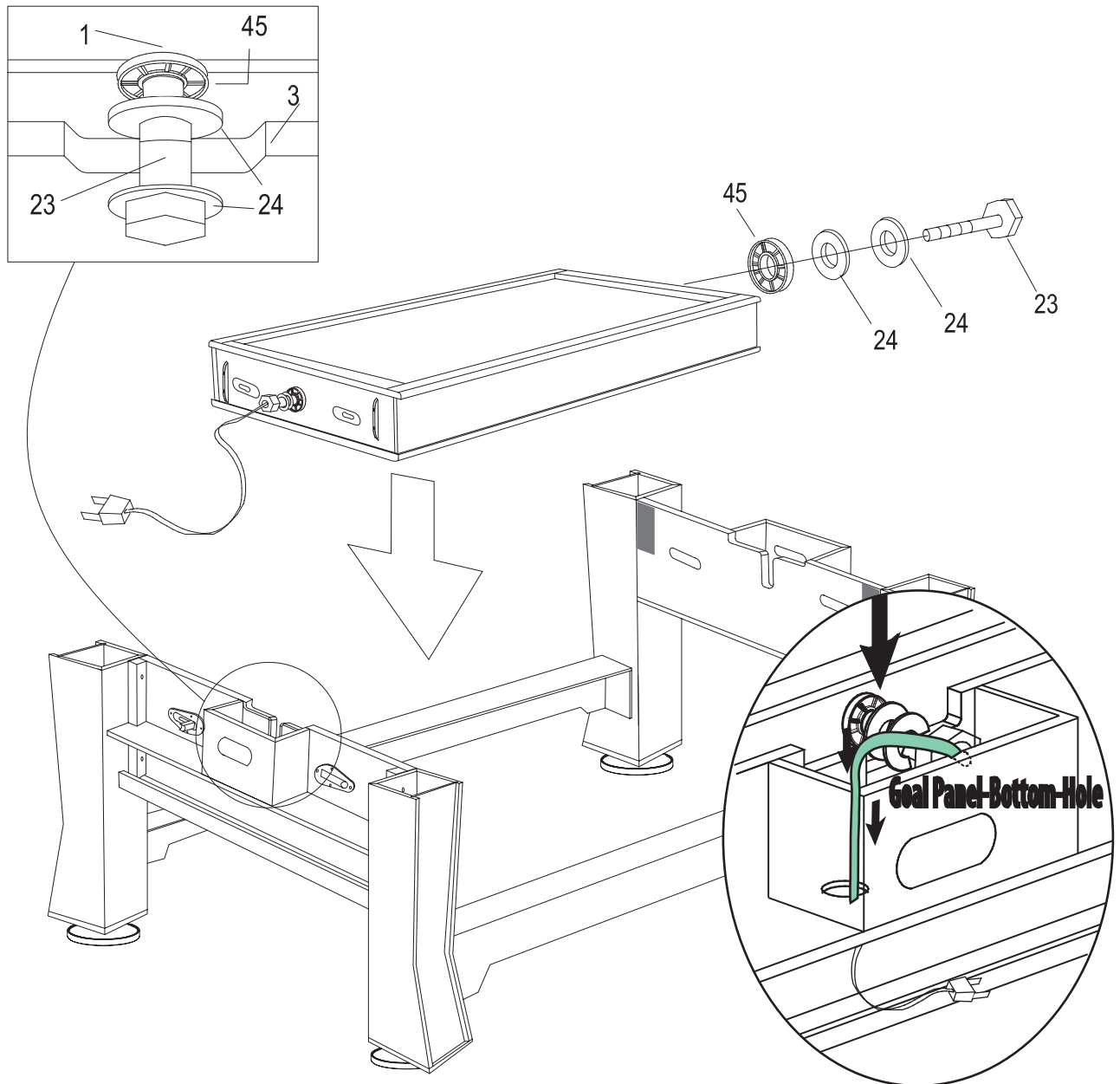

Step 9

Attach top side panel (#15) to the assembled leg pedestal (#3) by aligning the holes in the side panel (#15) with the predrilled holes in the top of the leg pedestal (#3) with screw (#20).

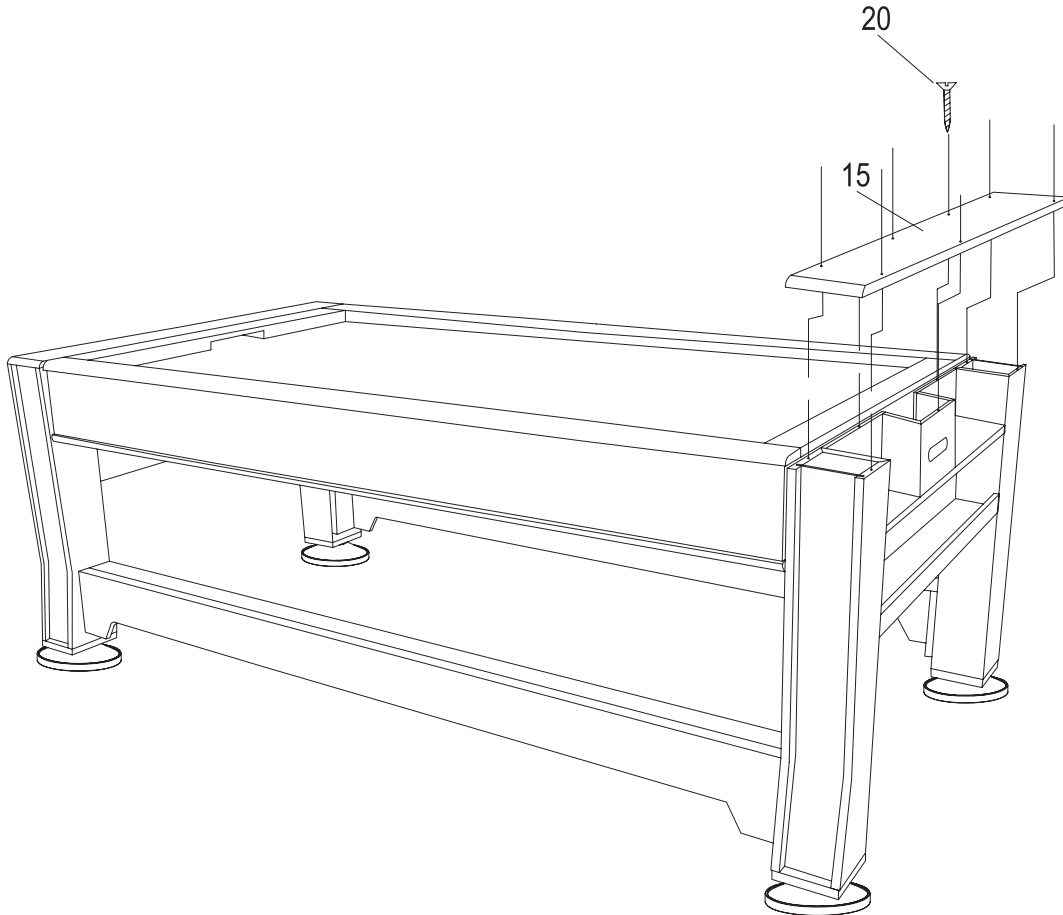

Step 10

Assemble the hockey striker (#35) by attaching the hockey felt (#36) by removing the protective paper and adhering the hockey felt (#36) to the striker (#35).

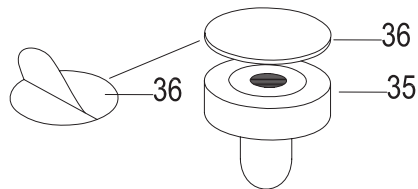

Step 11

Place the tennis top-support (#29) in the center of the table. Unfold the tennis surface-B (#17) and tennis surface-A (#16) and place on the table surface.

WARNING: Tennis top must be removed before rotating table top!

Trouble Shooting:

If the pool table side is not level first try to level by using the leg levelers on each leg. Most of the time the table can be easily leveled using this method. If the tennis top surface still needs adjustments shims may be used on the cross supports to bring up the low spots.

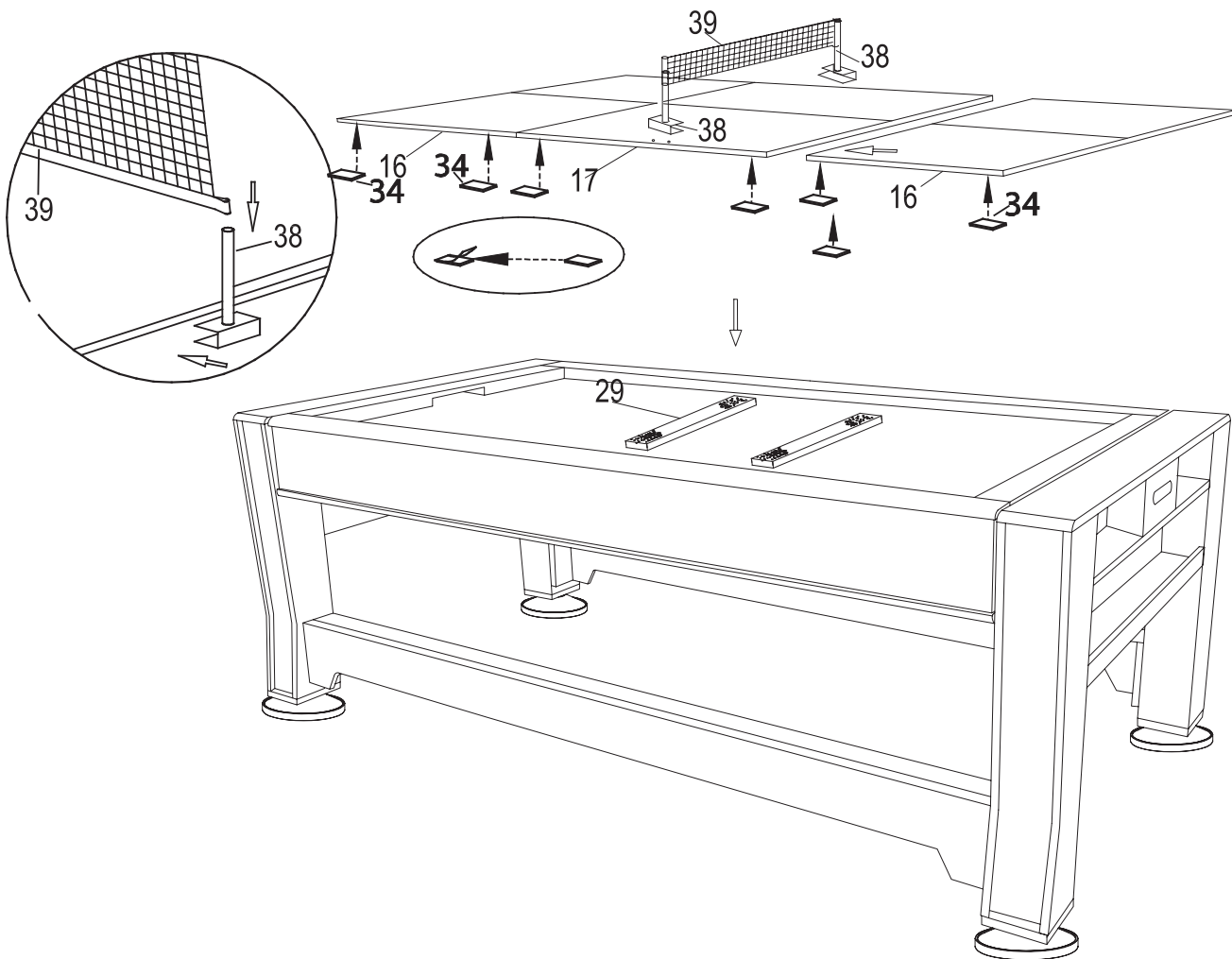

BILLIARDS:

After the break, regardless of whether any balls were pocketed on the break, the table is Open, with the choice of stripes or solids determined by the next legally pocketed ball.

In the course of play, a player must call each shot in advance, by indicating the ball to be made and the pocket into which it will be made. It is not necessary to indicate details such as cushions, banks, caroms, etc. Failure to make the shot as called results in a loss of turn. If the shot is made as called, then any other balls pocketed remain pocketed. However, if the called shot is not made and any other balls are pocketed, then the shooter's ball(s) that were pocketed would be spotted and any of the opponent's balls would remain pocketed.

In order to execute a Legal Shot, the first ball hit must be one of the balls in the shooter's group (stripes or solids) and the object ball must be pocketed or the cue ball or any object ball must come into contact with a rail. (Note: It is legal for the shooter to bank the cue ball off a rail before hitting the object ball.) A player who legally pockets a ball continues play until missing or committing a Foul. Once a player's ball group (stripes or solids) is pocketed, the player may play the 8 ball. Again, the player must clearly indicate the intended pocket, even if it appears obvious. A player who legally pockets all of his ball group and the 8 ball is the winner.

FOULS

1. Failure to execute a legal shot as defined above.
2. A scratch shot (shooting the cue ball into a pocket or off the table)
3. Moving or touching any ball by means other than legal play.
4. Shooting an intentional jump shot over another ball by scooping the cue stick under the cue ball.
A jump shot executed by striking the cue ball above center is legal.
5. Using the 8 ball first in a combination shot when the table is not open.

HOCKEY:

- 1) This game is designed to be played with two (2) players, one at each end, or with four (4) players, two at each end of the game table.
- 2) Play begins when the puck is placed on the playing surface. Players must hit the puck with the hand-held pushers and attempt to shoot into the opponent's goal.
- 3) One point is given when a puck is shot into the opponent's goal.
- 4) Winning: the winning goal is accomplished by being the first player to reach a predetermined score or by being the player to score the most points within a given period.

TABLE TENNIS:

In singles, the server first makes a good service and then the receiver makes a good return. Thereafter, server and receiver alternately each make a good return. In doubles, the server first makes a good service and the receiver returns the ball. Then the partner of the server makes a good return, followed by the partner of the receiver returning the ball. Thereafter, each player alternately in that sequence makes a good return.

Serving

After hitting it, the ball must first touch the server's own court and pass directly over the net or around the net assembly, then touching the receiver's court. In doubles, the ball must first touch the server's right half-court or center line, pass over the net, and then touch the receiver's right half-court or center line. If, in attempting to serve, a player fails to strike the ball while it is in play, he loses a point. Return After the ball is served or returned in play, it is struck so that it passes directly over the net and its assembly and touches the opponent's court. A returned ball which touches the net or its supports on the way over to the other side, is considered a good return. The ball is in play from the last moment at which it is stationary on the palm of the server's free hand before being projected in service until:

- a point is scored.
- it touches the same court twice consecutively.
- it has been volleyed.
- it touches a player, or anything he wears or carries, other than his racket or his racket hand below his wrist.
- it touches any object other than the net or its support (referred to above).
- it is struck by a player more than once consecutively.
- it touches, in a doubles service, the left half-court of the server or receiver.
- it is struck, in doubles, by a player out of sequence, except where there has been a genuine error in playing order.

