

---

**SIDE CHAIR**  
**CAISE D' APPOINT**  
**SILLA AUXILIAR**

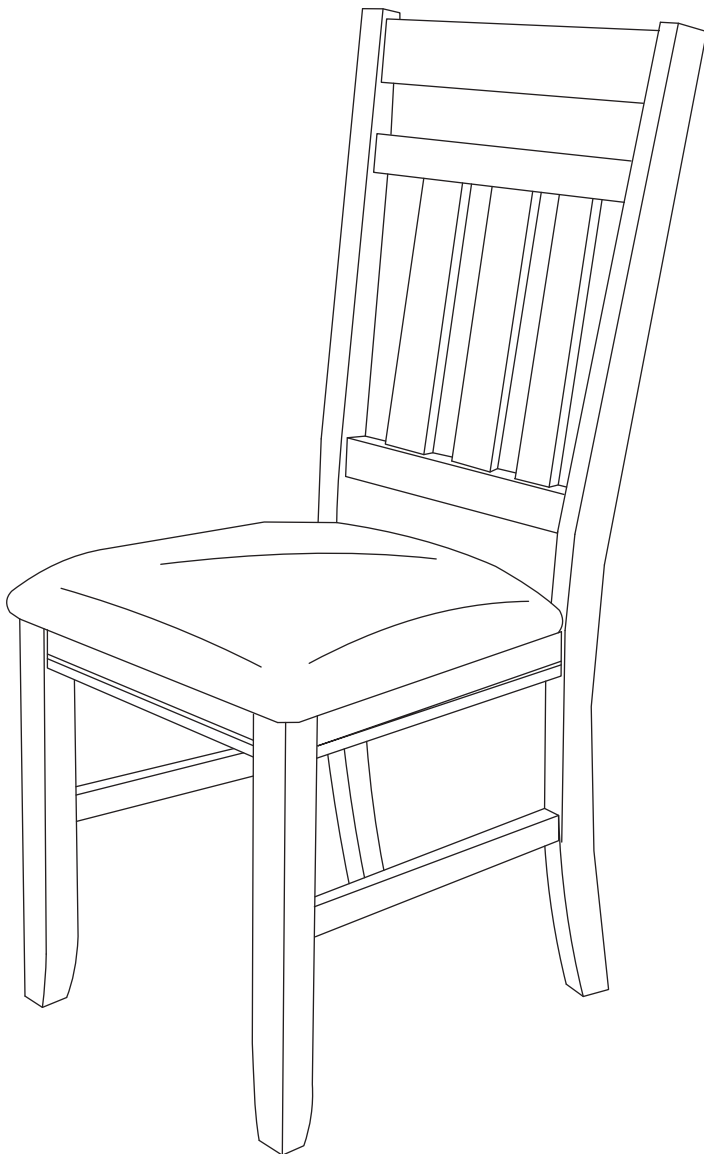





---

**We are here to help!**  
**Before you return it - contact us.**

**Nous sommes là pour vous aider!**  
**Avant de retourner le produit, veuillez communiquer avec nous.**

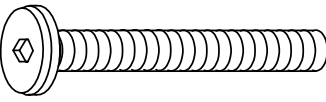
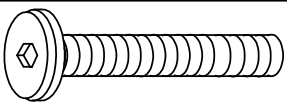
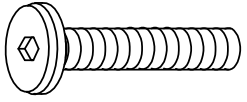
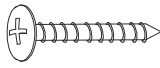
**Estamos aquí para ayudarle!**  
**Antes de regresar el producto, comuníquese con nosotros.**

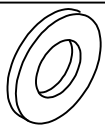
## HARDWARE LIST

			
H1x4 Ø1/4"x3"	H2x2 Ø1/4"x2-1/2"	H3x3 Ø1/4"x1-1/2"	
			
H4x4 #4x1-1/2"	H5x11 Ø1/4"	H6x11 Ø1/4"X16mm	H7x1 Allen wrench



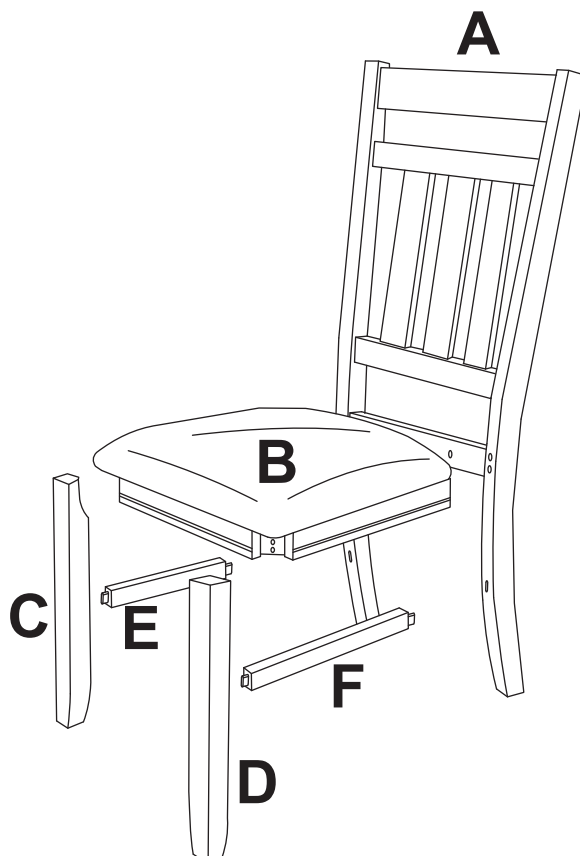

## PART LIST:

PARTS	DESCRIPTION	QTY
<b>A</b>	<b>CHAIR BACK</b>	<b>1</b>
<b>B</b>	<b>CUSHION</b>	<b>1</b>
<b>C</b>	<b>LEFT FRONT LEG</b>	<b>1</b>
<b>D</b>	<b>RIGHT FRONT LEG</b>	<b>1</b>
<b>E</b>	<b>LEFT SIDE STRETCHER</b>	<b>1</b>
<b>F</b>	<b>RIGHT SIDE STRETCHER</b>	<b>1</b>

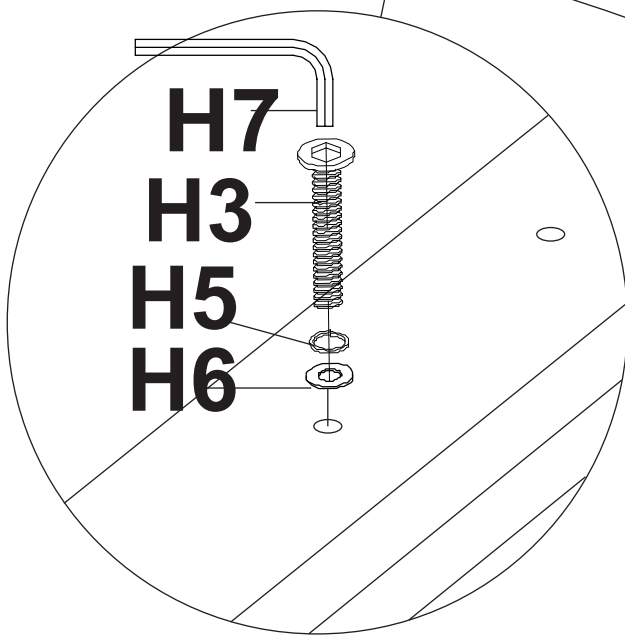
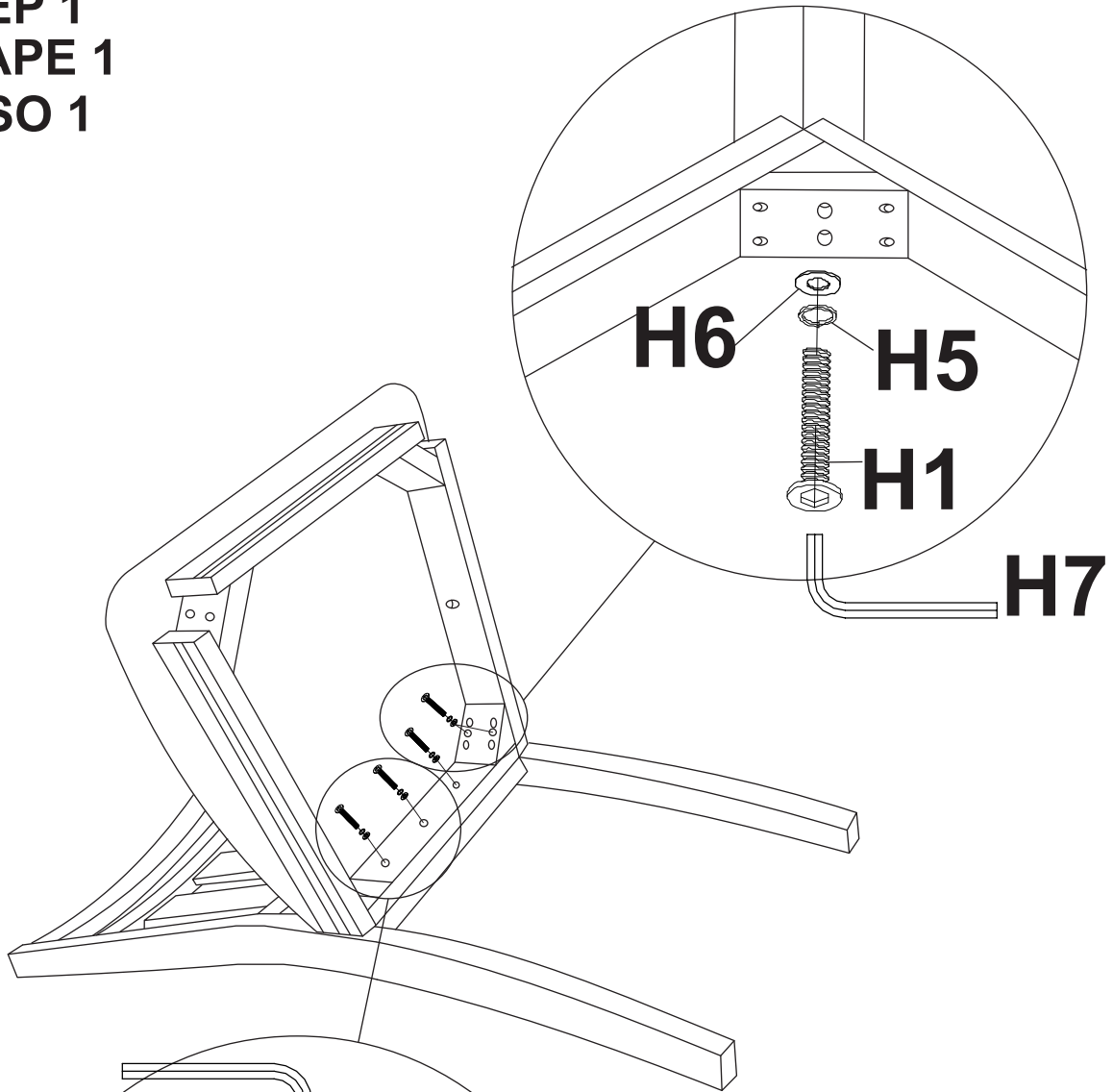



**STEP 1**  
**ÉTAPE 1**  
**PASO 1**

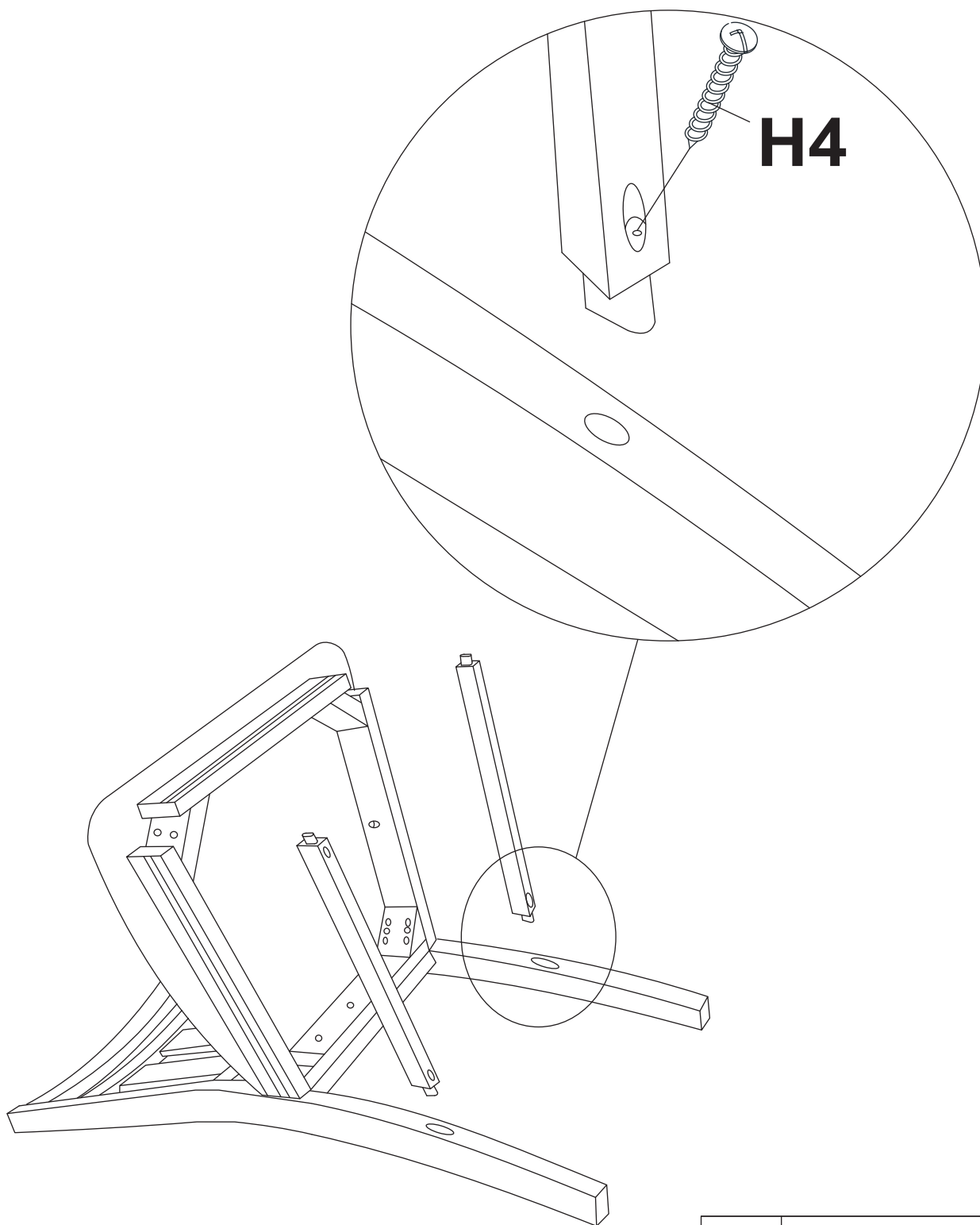

<b>H1</b>		4
<b>H3</b>		3
<b>H5</b>		7
<b>H6</b>		7
<b>H7</b>		1

**STEP 2**  
**ÉTAPE 2**  
**PASO 2**







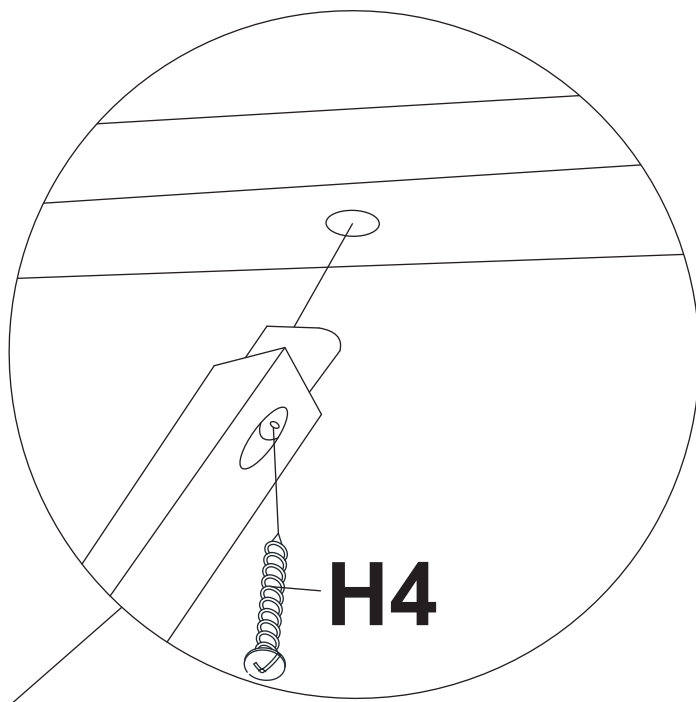
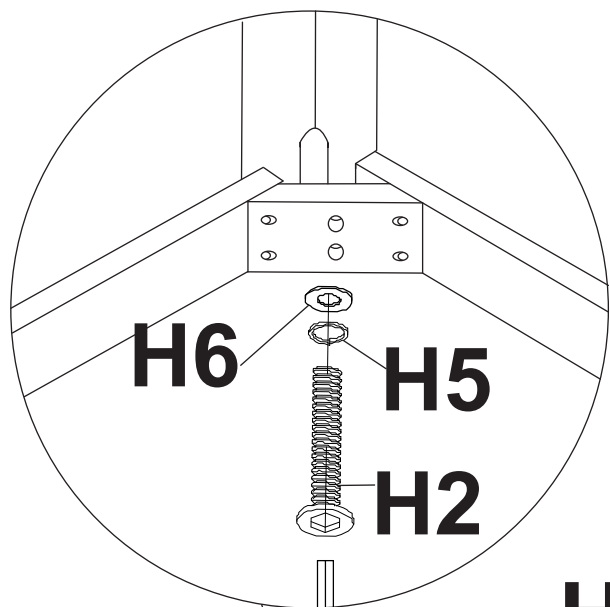

<b>H4</b>		<b>2</b>
-----------	---	----------

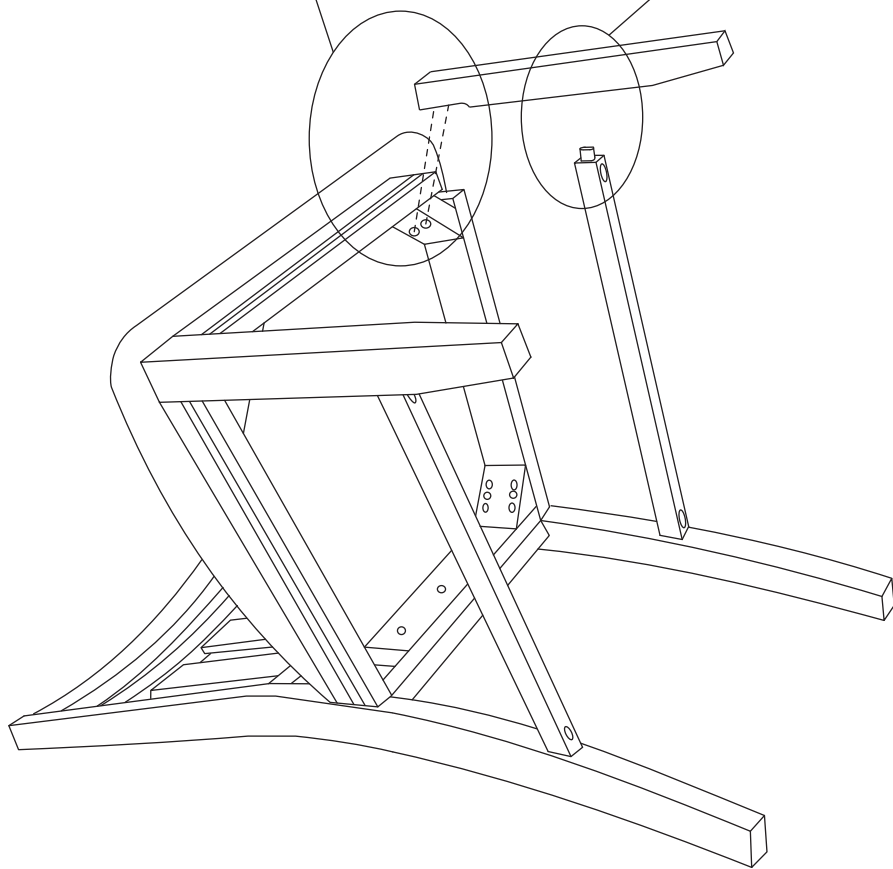
**STEP 3**  
**ÉTAPE 3**  
**PASO 3**



**H7**



<b>H2</b>		4
<b>H4</b>		2
<b>H5</b>		4
<b>H6</b>		4
<b>H7</b>		1

---

**LIMITED WARRANTY**  
**GARANTIE LIMITÉE DE**  
**GARANTÍA LIMITADA DE**

MADE IN VIETNAM  
FABRIQUÉ AU VIETNAM  
HECHO EN VIETNAM

