

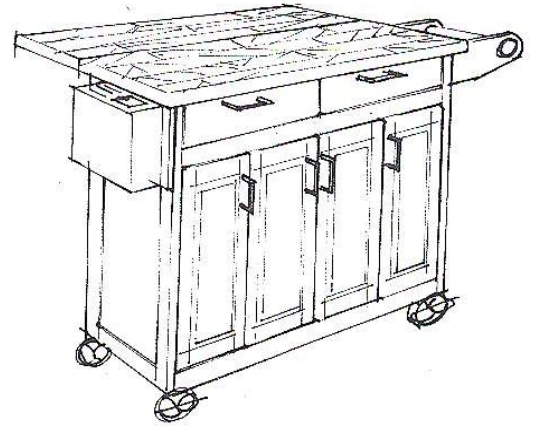

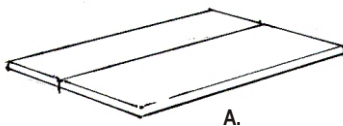













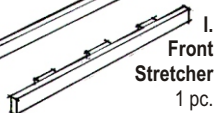
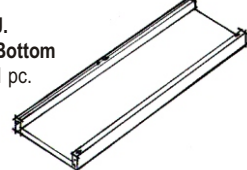

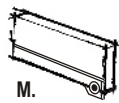
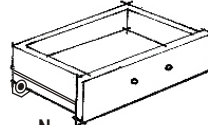
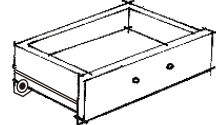
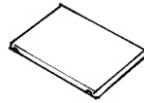

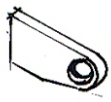

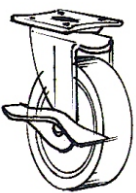

Thank you for purchasing our quality products. Please carefully check the quantity of the parts and hardware. Please also read this assembly instructions until you understand clearly how to put the parts together then start assembling step by step.



## PART LIST

 <b>A. Top</b> 1 pc.		 <b>B. Side Frame L.</b> 1 pc.	 <b>C. Middle Frame</b> 2 pcs.	 <b>D. Side Frame R.</b> 1 pc.	 <b>E. Small Back Panel</b> 2 pcs.	 <b>F. Large Back Panel</b> 1 pc.	 <b>G. Back Post</b> 2 pcs.
 <b>H. Back Stretcher</b> 1 pc.	 <b>I. Front Stretcher</b> 1 pc.	 <b>J. Bottom</b> 1 pc.	 <b>K. Door L.</b> 2 pcs.	 <b>L. Door R.</b> 2 pcs.	 <b>M. Drawer Divider.</b> 1 pc.	 <b>N. KD. Drawer L.</b> 1 pc.	 <b>O. KD. Drawer R.</b> 1 pc.
 <b>P. Small Shelf</b> 2 pcs.	 <b>Q. Large Shelf</b> 1 pc.	 <b>R. Gate Leg</b> 1 pc.	 <b>S. Handle Arms</b> 2 pcs.	 <b>T. Round Arm</b> 1 pc.	<p>(For Drawer N&amp;O Packed in separate carton with hardware and assembly instructions.)</p>		 <b>U. Knife Box</b> 1 pc.

## HARDWARE LIST

 <b>Caster with and without brake</b> 4 pcs.	 <b>Head Cap Bolt</b> 13 pcs. (+1Extra)	 <b>Cam Lock Screw</b> 6 pcs. (+1Extra)	 <b>Pull Handle</b> 4 pcs.	 <b>Wood Screw</b> 20 pcs. (+2 Extra)	 <b>Wood Plug</b> 6 pcs. (+2 Extra)
 <b>Hex Wrench</b> 1 pc.	 <b>Cam Lock</b> 6 pcs. (+1Extra)	 <b>Machine Screw for Pull Handle</b> 8 pcs.	 <b>Adjustable Pin</b> 12 pcs. (+2Extra)		

# Assembly Instructions 2/3

## IMPORTANT

Do not tighten up all the screws until each part is properly assembled. You should keep Hex Wrench in the safe place as you may need to tighten up the Head Cap Bolts in the future.

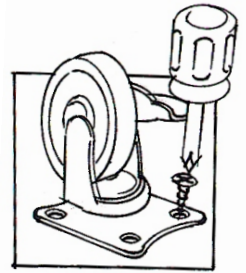

## STEP 1

Attach 4 Casters to the under side of the Bottom (J), put the 2 Casters with brakes in front as you first need to lock the cart from moving. (See sticker in the bottom indicating front side)

## STEP 2

Attach the Side Frame (D) to the Bottom (J). Tighten Head Cap Bolt only half way. Place the Back Posts (G) on the Bottom rear. Attach the Middle Frame (C) with the Back Posts (G).

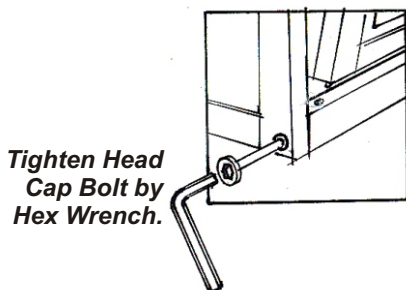
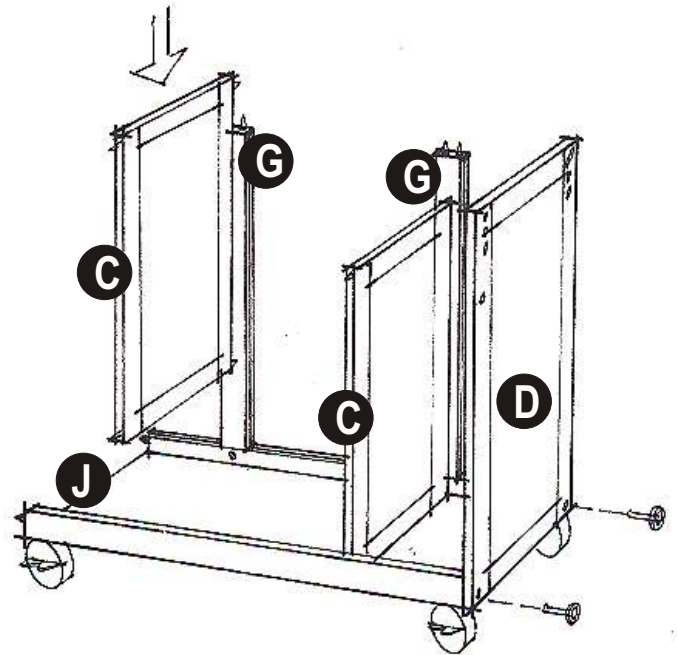

Tighten Head Cap Bolt by Hex Wrench.

## STEP 3

Slide the Back Panels (E),(F) in places. Place the Back Stretcher (H) on Back Panels(E),(F) insert the Head Cap Bolts through the Side Frame (D), then tighten them only half way.

Place the Front Stretcher(I) in front, then tighten all Head Cap Bolt half way. Attach the Drawer Divider(M) to the Back Stretcher(H) and Front Stretcher(I). Tighten Head Cap Bolt. Attach the Side Frame (B) to the left side of the assembled body. Retighten all Head Cap Bolts.

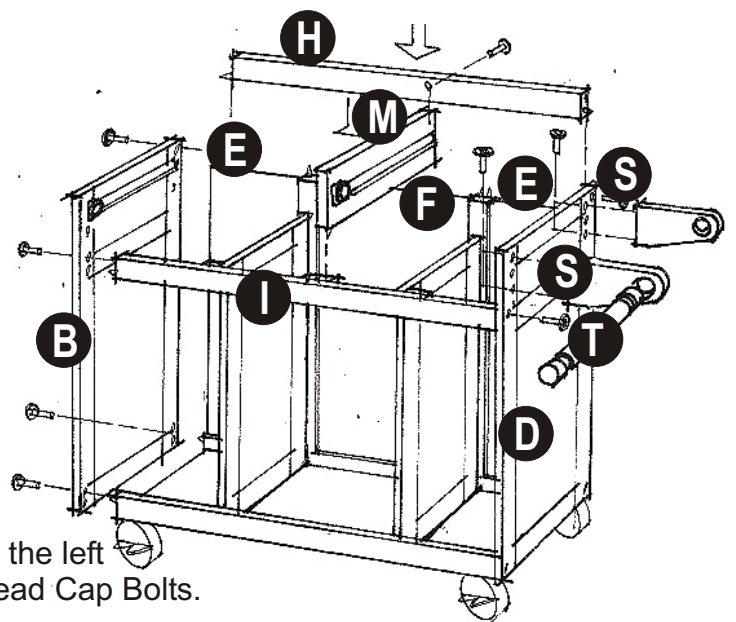

Attach the Handle Arms (S) using Head Cap Bolts from the inside and slide the Round Arm (T) in place.

# Assembly Instructions 3/3

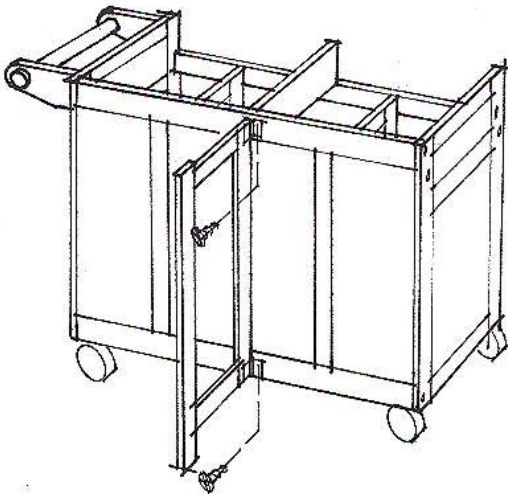

## STEP 4

Place the Gate leg (R) on the rear and hold on back frame with Wood Screws.

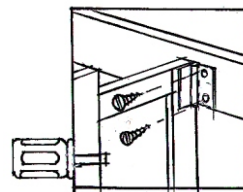

*Holding Gate Leg and rear frame with Wood Screw*

## STEP 5

Attach the Knife Box (U) to the Side Frame (B) with the Head Cap Bolts.

Place the Cam Lock Screws into the Top holes, then place the Top(A) on the assembled body. Place the Cam Locks into the holes of the Side Frames (B) and (D), ***Make sure the Arrow sing on top.***

Attach the Doors (K),(L) to the Front Stretcher (I) and Bottom (J) using Spring Pin Hinge. Assemble the Door and Drawer Pull Handles using the Machine Screws.

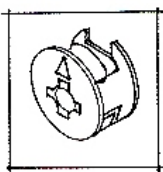
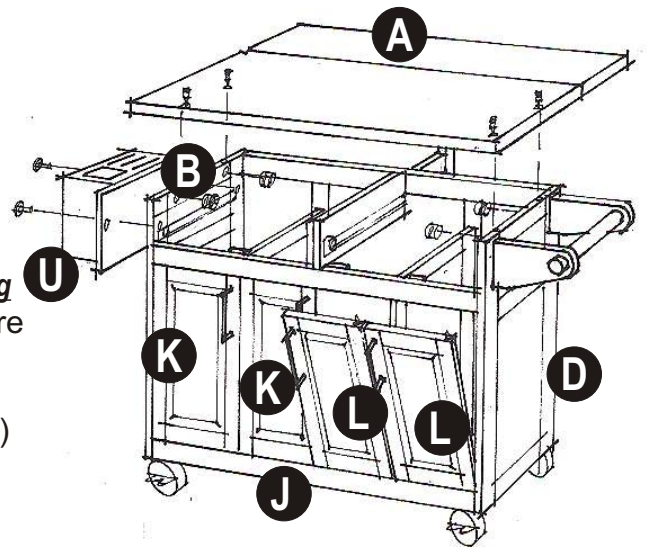

See the "Arrow" on top

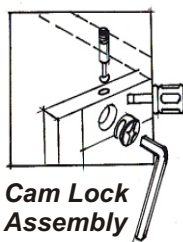

*Cam Lock Assembly*

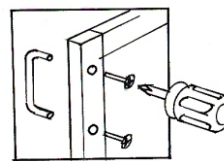

*Pull Handle Assembly*

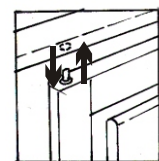

*Door Assembly using Spring Pin Hinge*

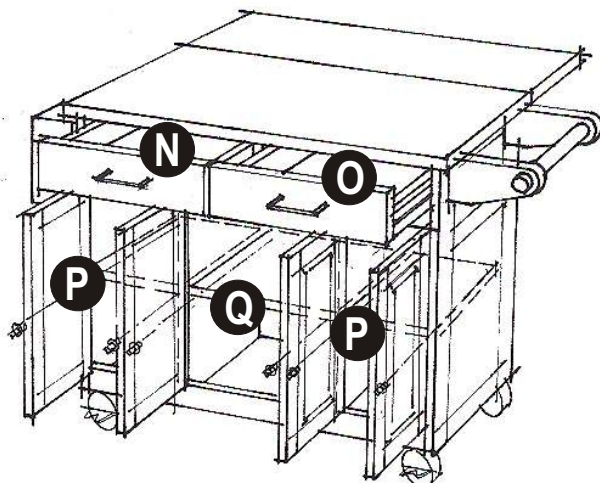

## STEP 6

Put the Adjustable Pins into the side panel, in the desired position. Place Shelf (P),(Q). Slide the Drawer(N) and Drawer(O) in places.

## STEP 7

Cover all holes with Wood Plugs

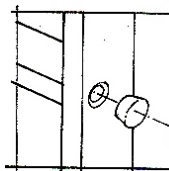



# Drawer (N) Drawer (O)

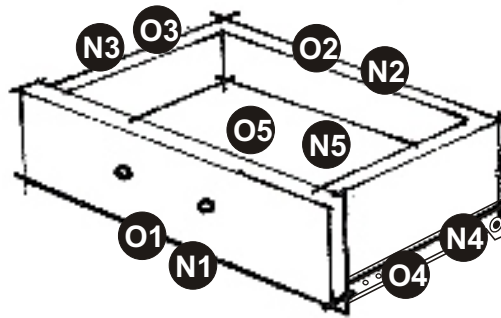

## Unit Part List

## HARDWARE LIST

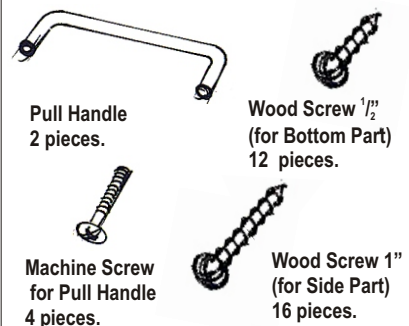
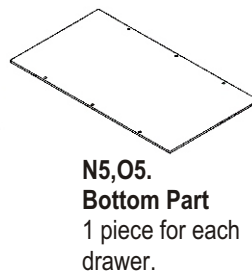
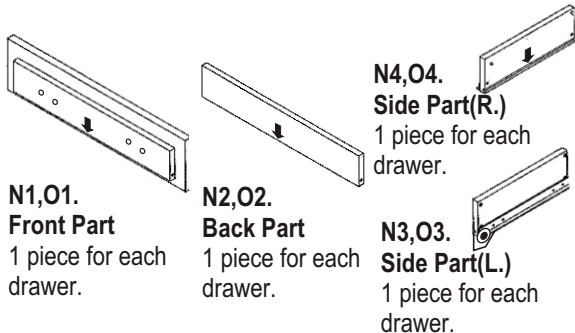

## Assembly Instructions

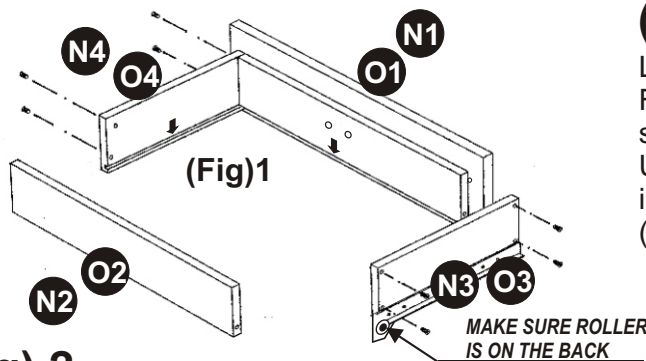

**(Fig) 1**

Line up Side Parts (N3,O3) and (N4,O4) to the Front Part (N1,O1) and Back Part (N2,O2). Be sure to follow the 'Arrow' sign sticker on the parts. Using a **Phillip's** screw driver, insert 1" screws into each of the 4 pre-drilled holes in sides (N3,O3) and (N4,O4), then tighten half way.

**(Fig) 2**

Turn the assembled drawer over and slide the Plywood Bottom Part (N5,O5) into the grooves on Side Parts (N3,O3) and (N4,O4). Be sure to push the plywood all the way forward so it meets the Front Part (N1,O1).

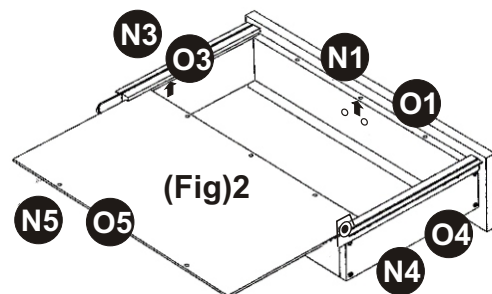

**(Fig) 3**

Insert the remaining (6) 1/2" screws into the pre-drilled holes in Bottom Part (N5,O5), then tighten all screws

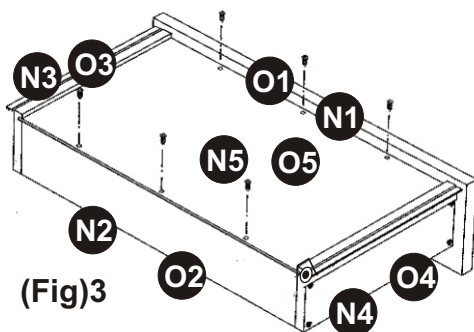

**(Fig) 4**

Assemble the Pull Handle with Machine Screw on the Front Part (N1,O1).

