

Metal Garden Shed

5x3FT

Assembly Instruction

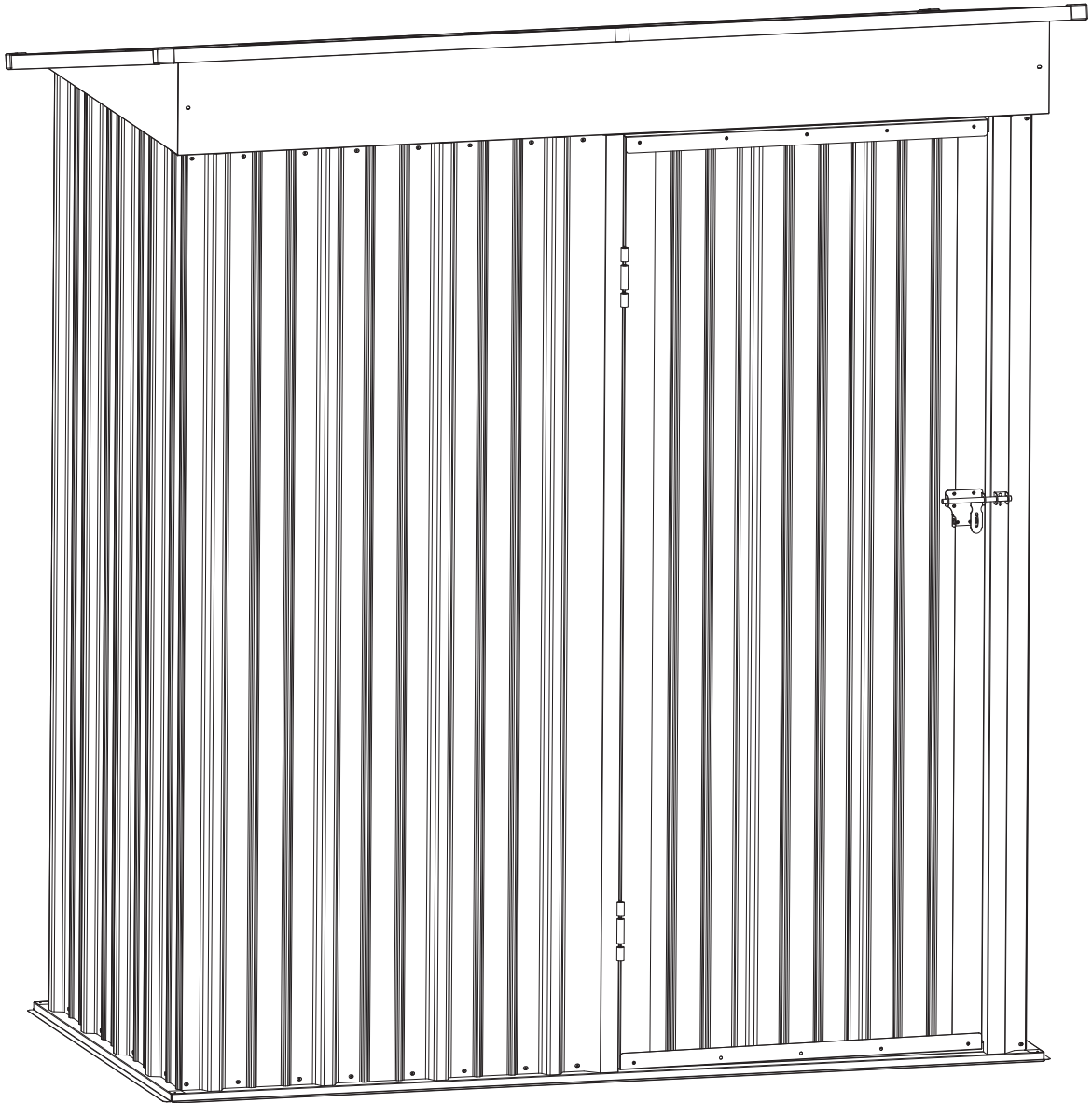

Requires two people and takes 2-3 hours for Installation.
Recommended to wear gloves to avoid scratches

Tall Walk in Shed
Quick & Easy Assembly
Ridge Reinforced Walls
Available in Various Sizes

Contact Weave Support

Need service or support?
Start your request by Emailing Us.
AND we will find you a Solution.

E-mail: HelloweaveGaming@Gmail.com
Cell: 5419085215 10am-4:30pmPST

PLAN AHEAD

Before beginning installation, check local building codes regarding footings, location and other requirements.

Study and understand this instruction.

Important information and helpful tips will make your installation easier and more enjoyable.

Tools and Materials: There are some basic tools and materials you will need for the installation. Decide which method of anchoring and the type of foundation you wish to use in order to form a complete list of the materials you will need.

BEFORE YOU BEGIN







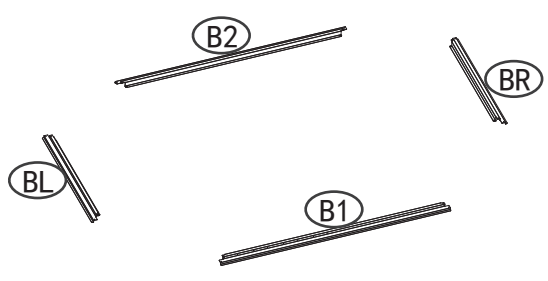
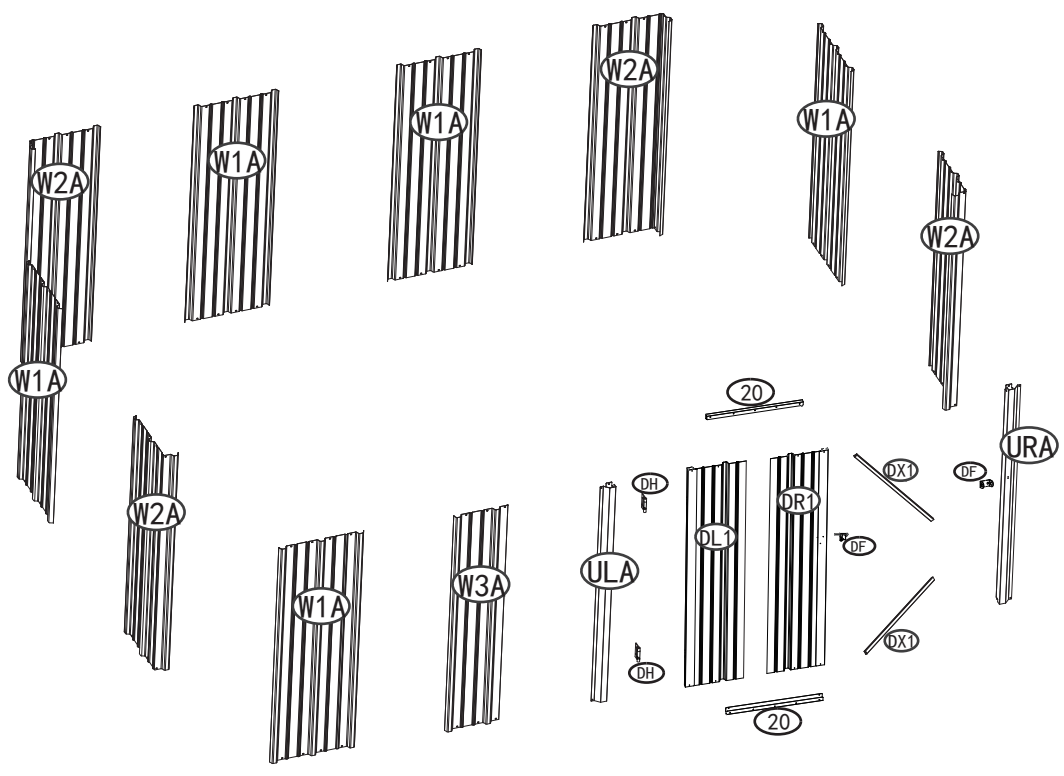
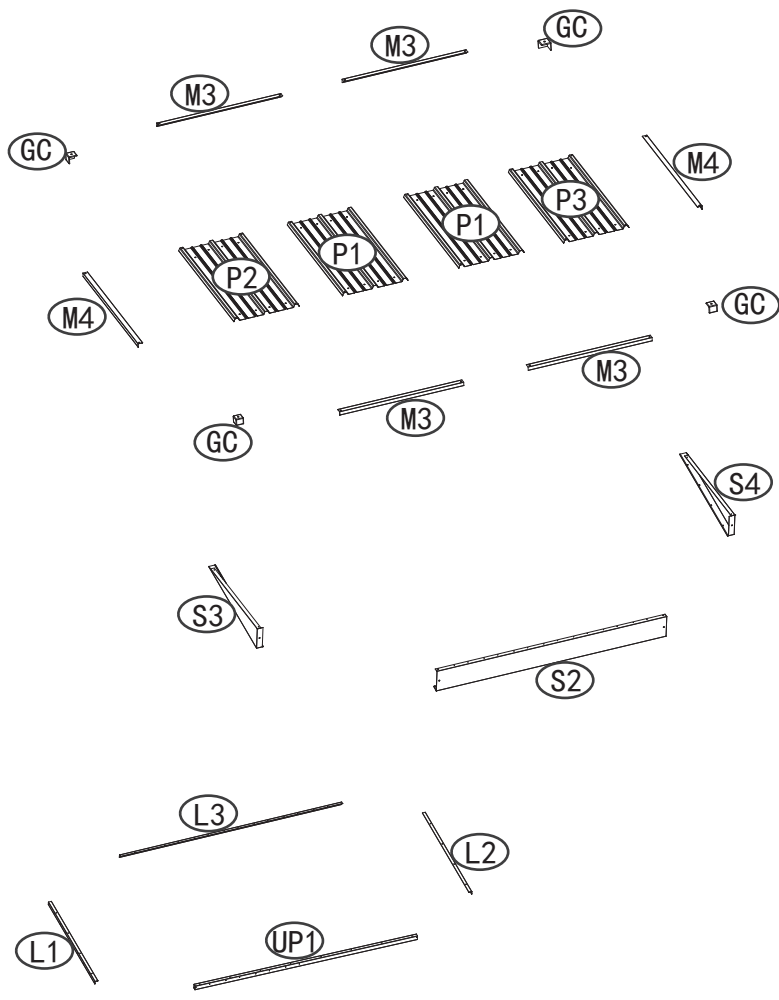













Assembly Instruction: Instructions are supplied in this manual and contain all appropriate information for your installation. Review all instructions before you begin, and during assembly, follow the step sequence carefully for correct results.













Parts List: Check to be sure that you have all the necessary parts and quantities in your package. These are packaged within the carton. Note that extra fasteners have been supplied for your convenience.





Explosion Diagram: All parts except screws and bolts are shown in this diagram, review all parts before you begin. Familiarize yourself with the hardware and fasteners for easier use during installation.





PARTS LIST

PART	NO.	Qty.
	B1	1
	B2	1
	BL	1
	BR	1
	L1	1
	L2	1
	L3	1
	UP1	1
	M3	4
	M4	2
	W1A	5
	W2A	4
	W3A	1
	ULA	1
	URA	1
	20	2
	DL1	1
	DR1	1
	DF	1
	DX1	2
	DH	2
	DG	1

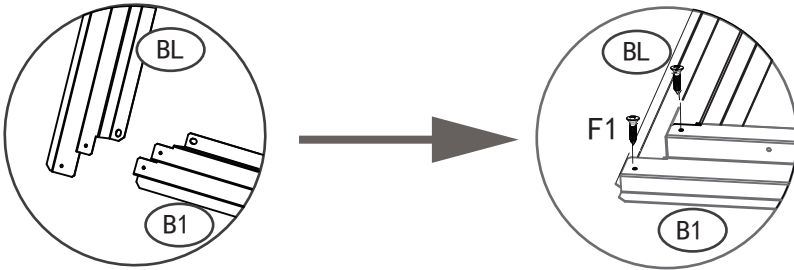
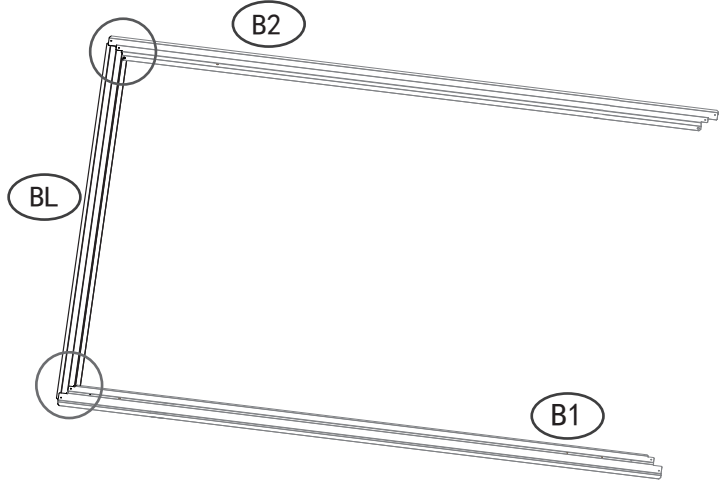
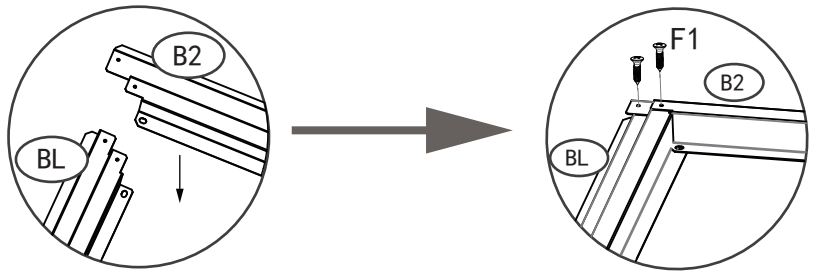

PART	NO.	Qty.
	S2	1
	S4	1
	S3	1
	P1	2
	P2	1
	P3	1
	GC	4
	F1	168
	F2	10
	F3	16
	V2	150
	S1	150

PART	NO.	Qty.
	B1	1
	B2	1
	BL	1
	F1	4



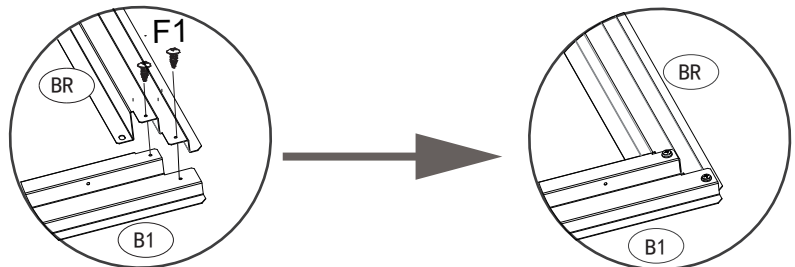
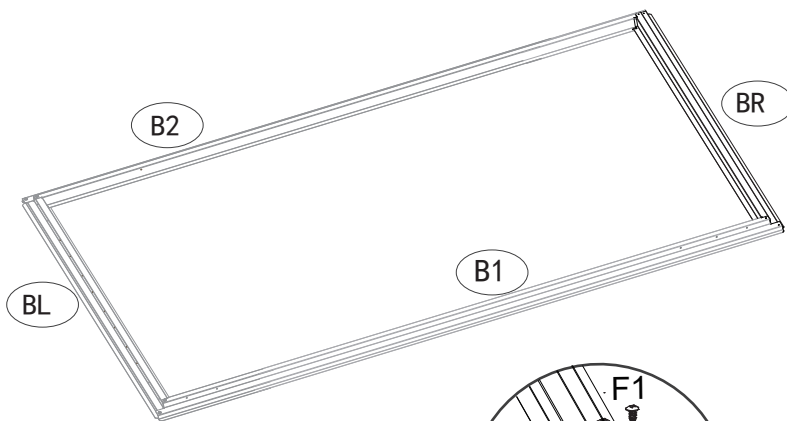
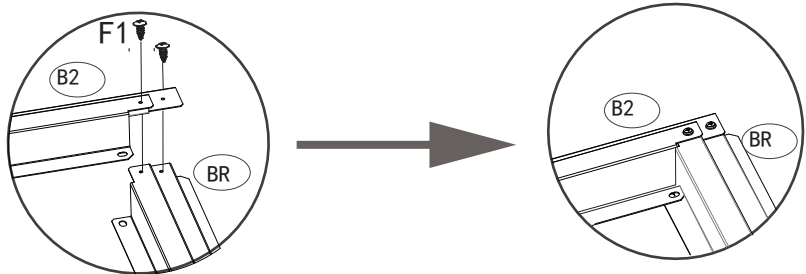

PART	NO.	Qty.
	BR	1
	F1	4



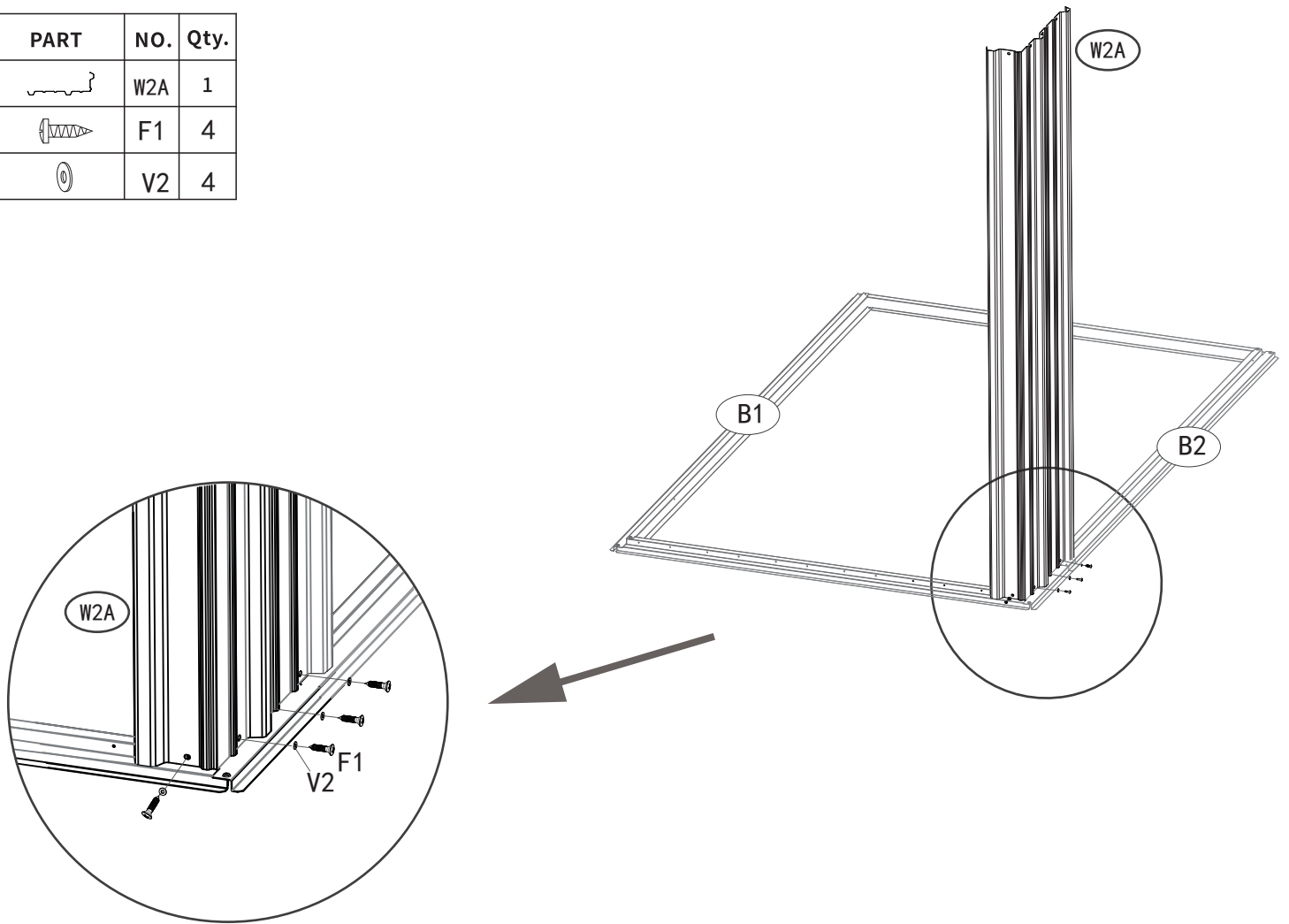

PART	NO.	Qty.
	W2A	1
	F1	4
	V2	4



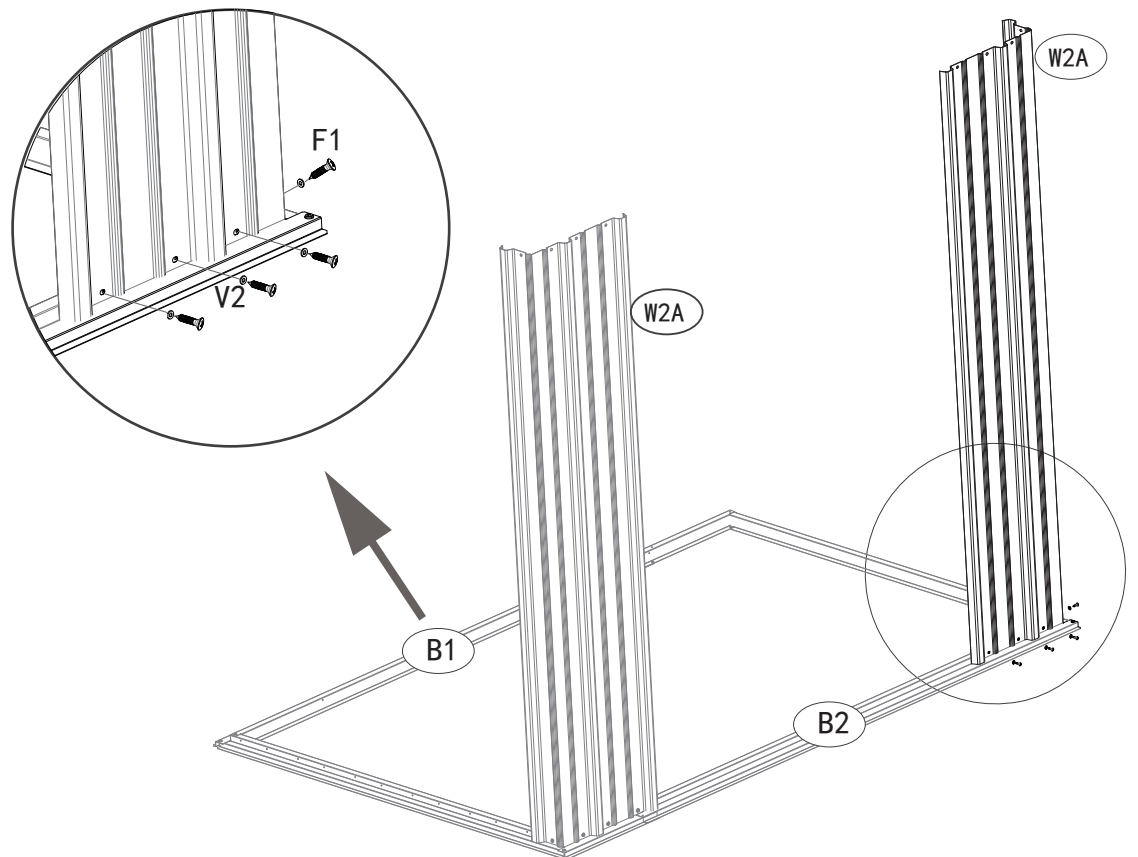

PART	NO.	Qty.
	W2A	1
	F1	4
	V2	4



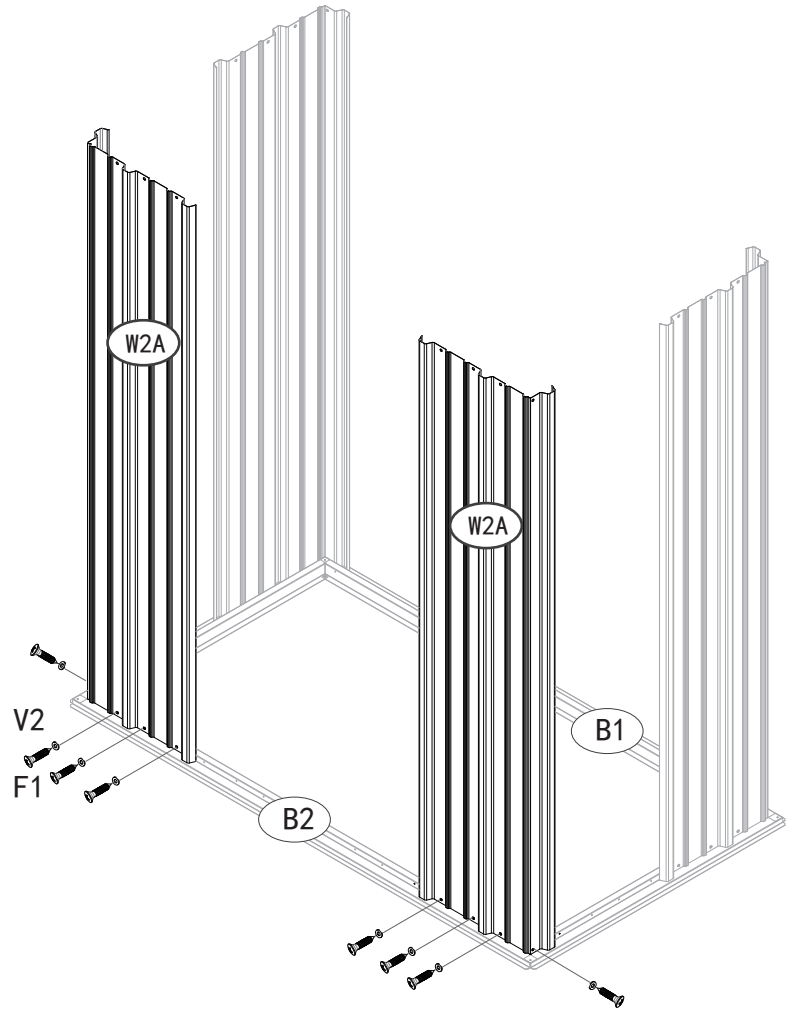



PART	NO.	Qty.
	W2A	2
	F1	8
	V2	8

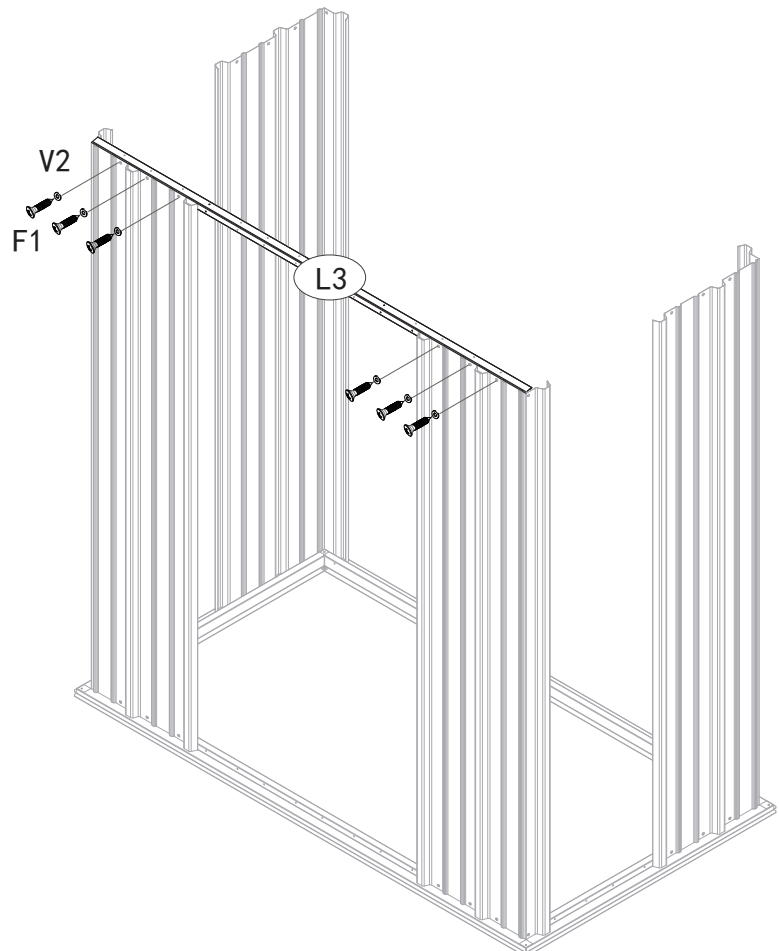



PART	NO.	Qty.
	L3	1
	F1	6
	V2	6



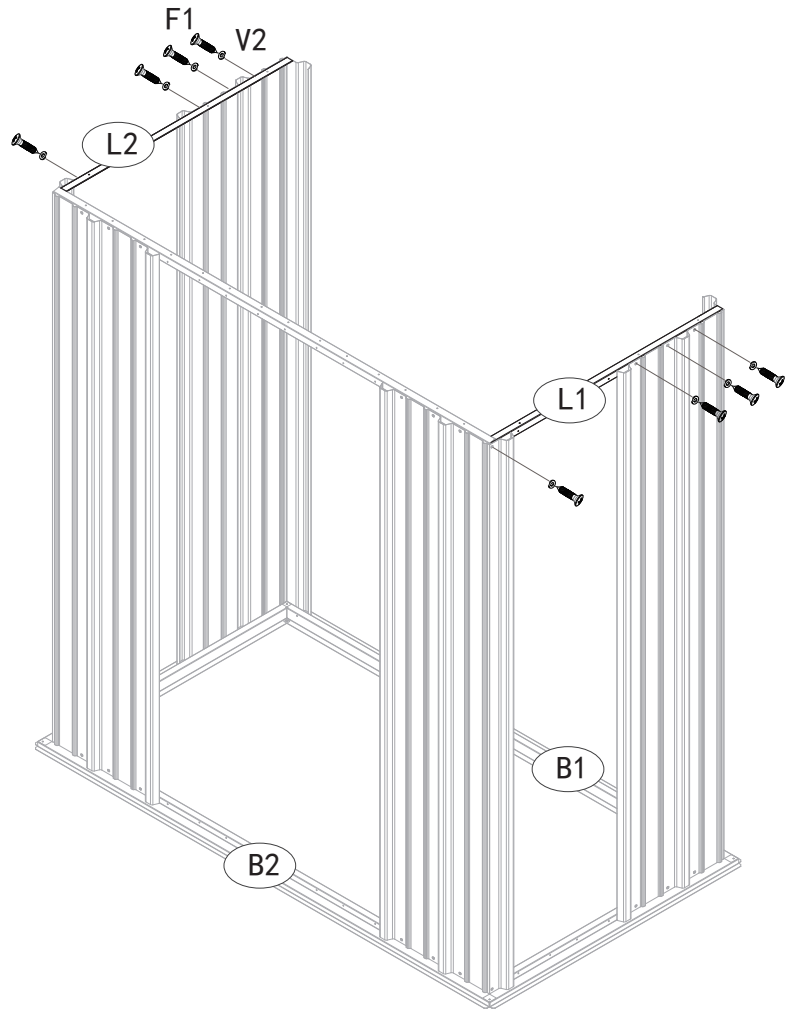

PART	NO.	Qty.
	L1	1
	L2	1
	F1	6
	V2	6



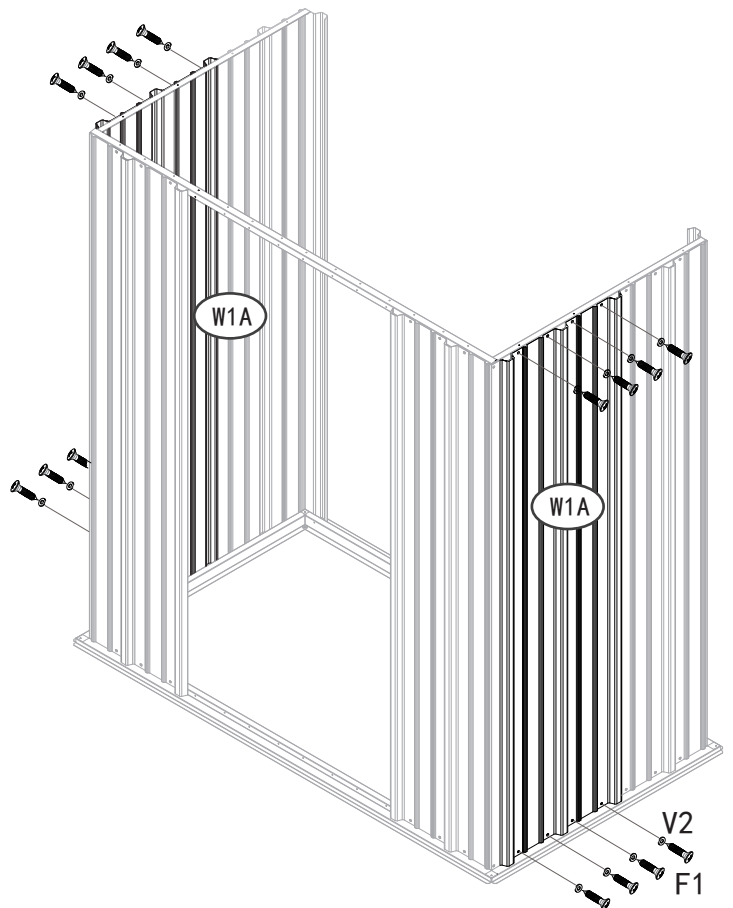

PART	NO.	Qty.
	W1A	2
	F1	16
	V2	16



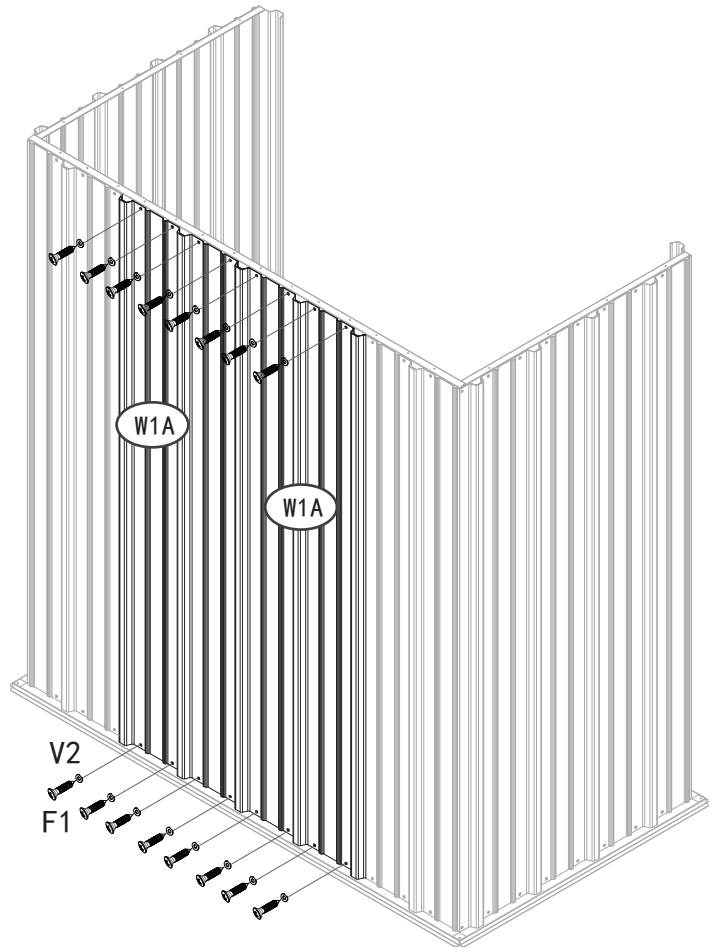

PART	NO.	Qty.
	W1A	2
	F1	16
	V2	16



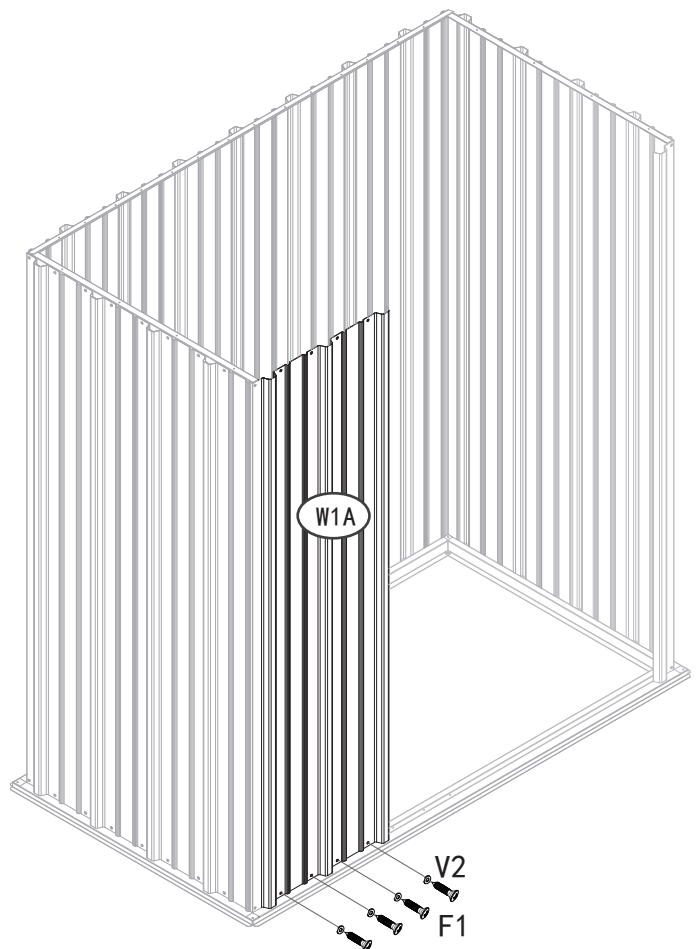

PART	NO.	Qty.
	W1A	1
	F1	4
	V2	4



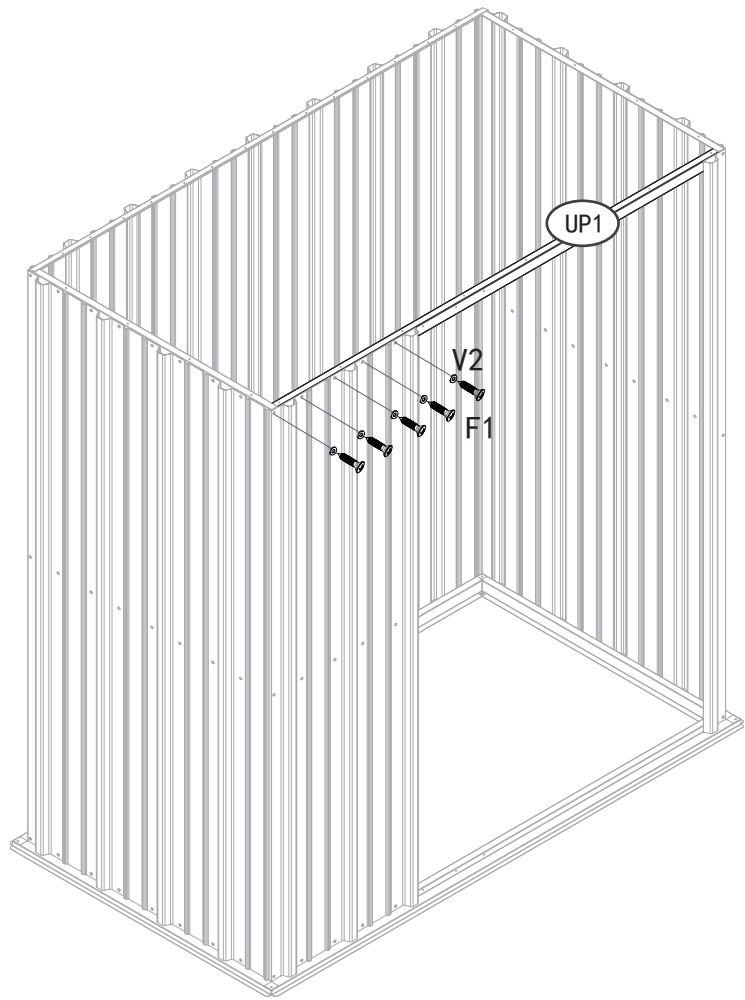



PART	NO.	Qty.
	UP1	1
	F1	5
	V2	5

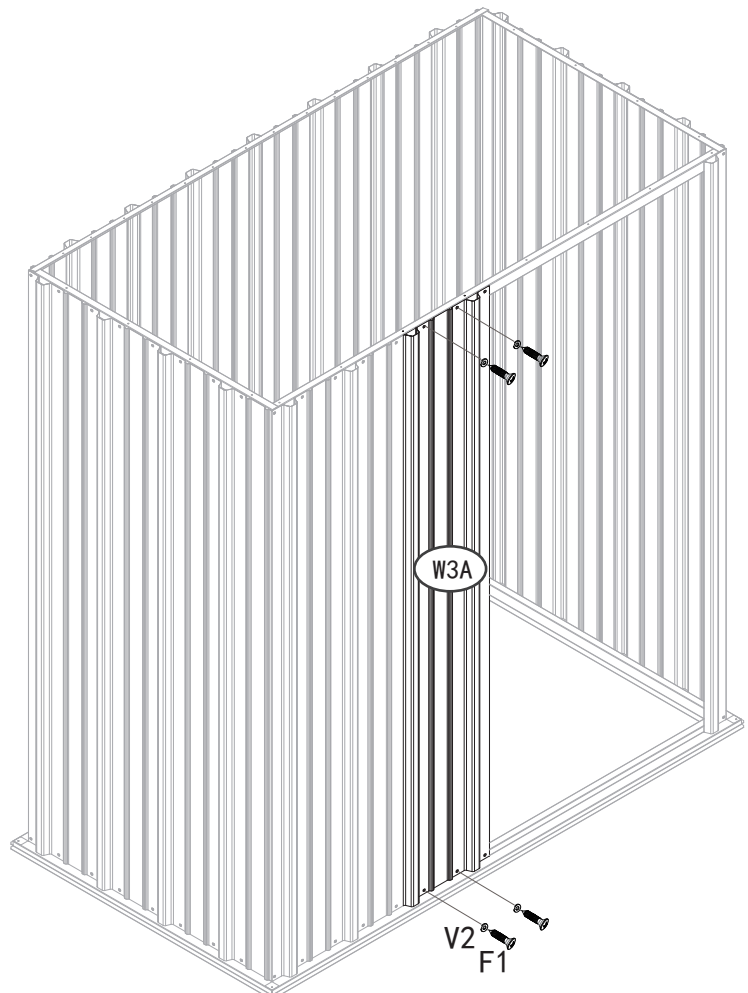

PART	NO.	Qty.
	W3A	1
	F1	4
	V2	4



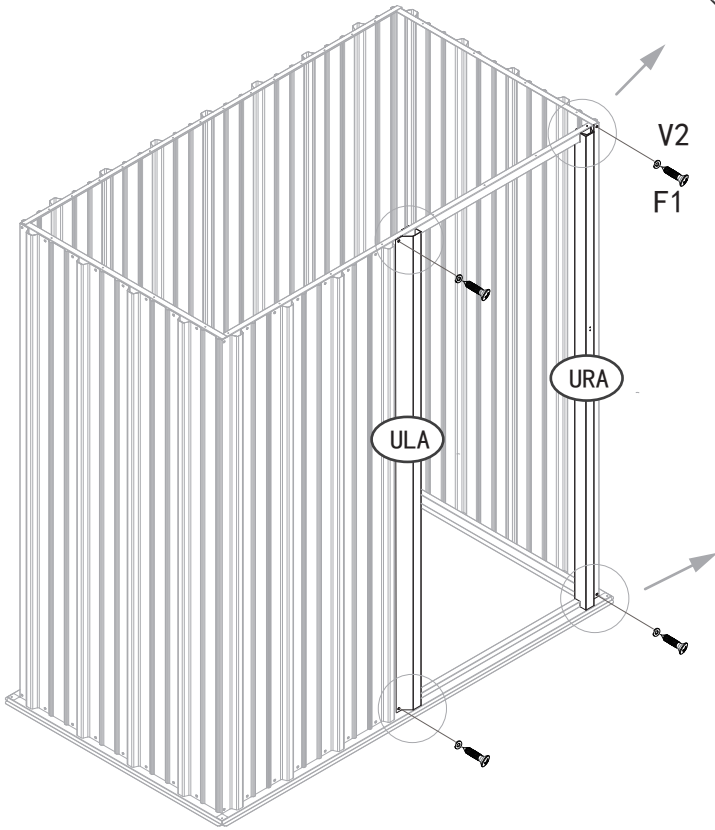
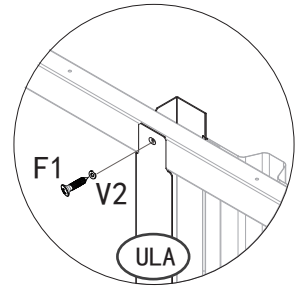
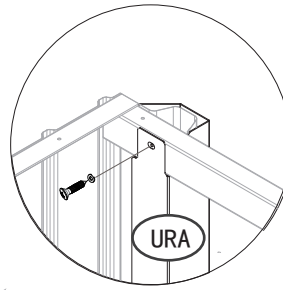

PART	NO.	Qty.
	URA	1
	ULA	1
	F1	8
	V2	8



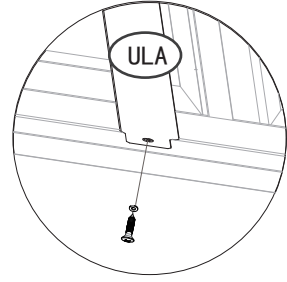
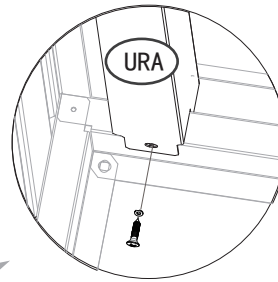



internal setup

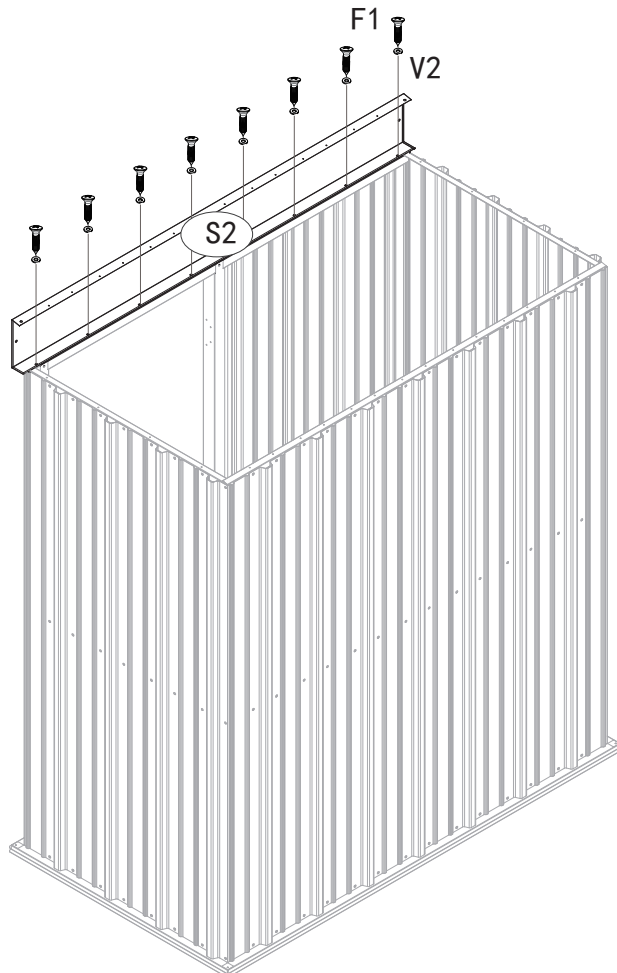





PART	NO.	Qty.
	12L	1
	F1	8
	V2	8

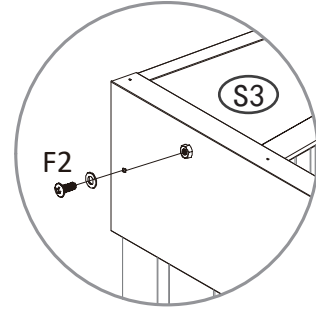
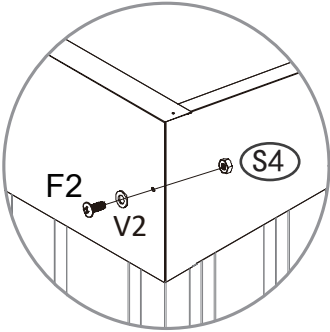
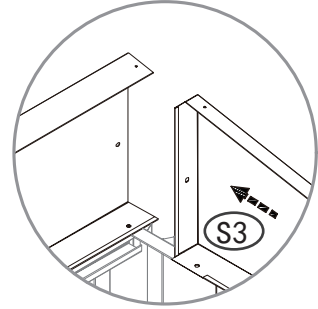
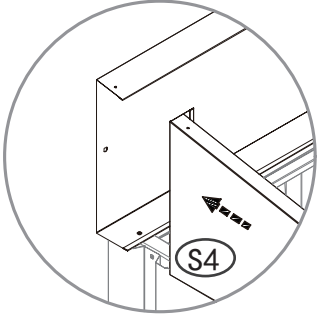
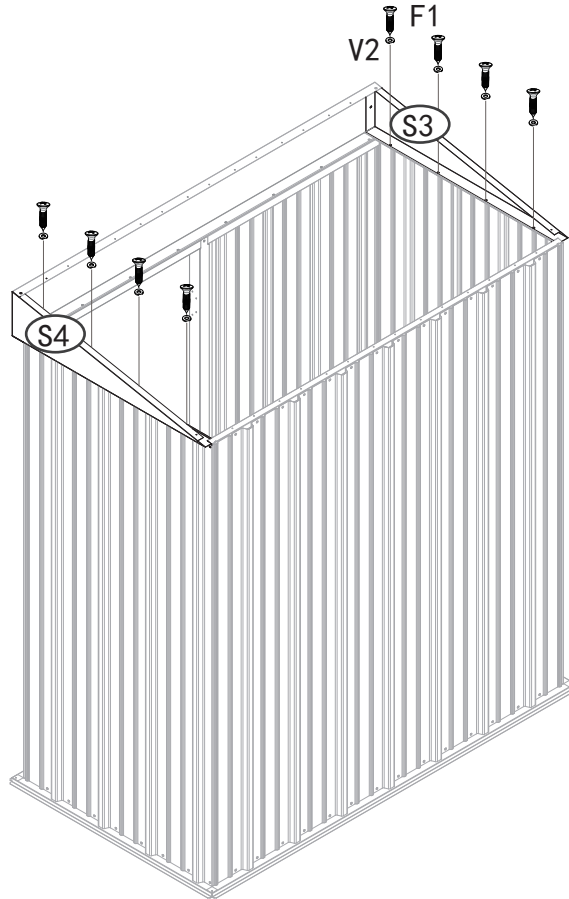

PART	NO.	Qty.
	S3	1
	S4	1
	F1	8
	V2	10
	F2	2



PART	NO.	Qty.
	P1	2
	P2	1
	P3	1
	F1	32
	V2	32

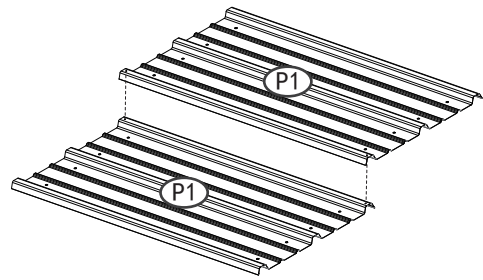
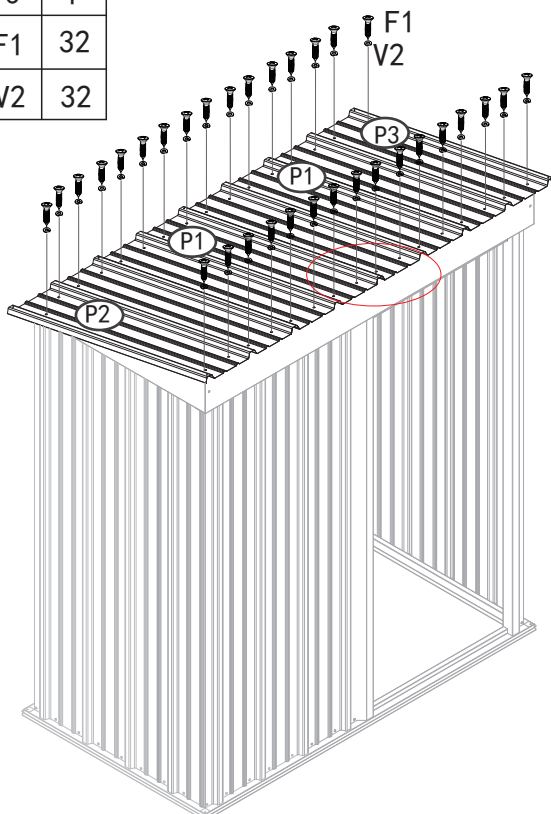

Pls pay attention to assembling way of roof panels!

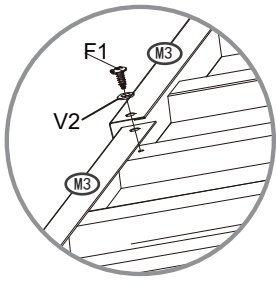



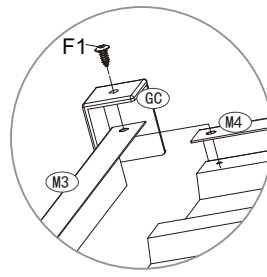

x2

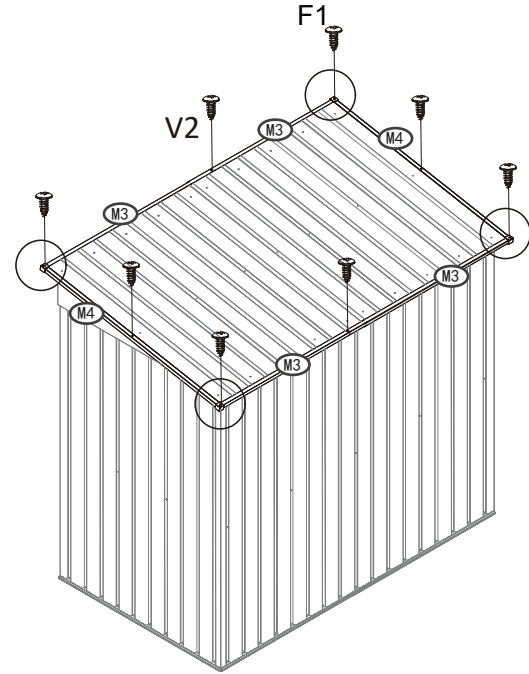
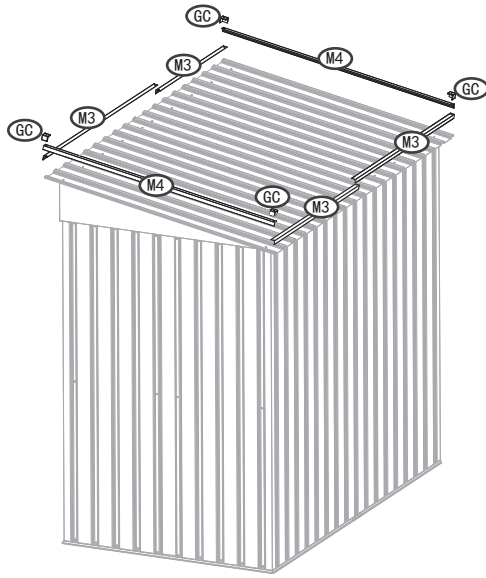





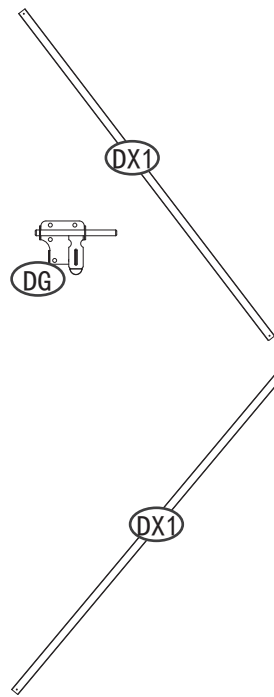
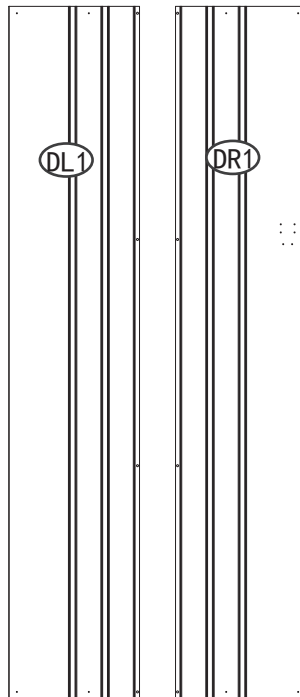
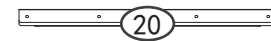

x4





PART	NO.	Qty.
	M3	4
	M4	2
	GC	4
	F1	8
	V2	4

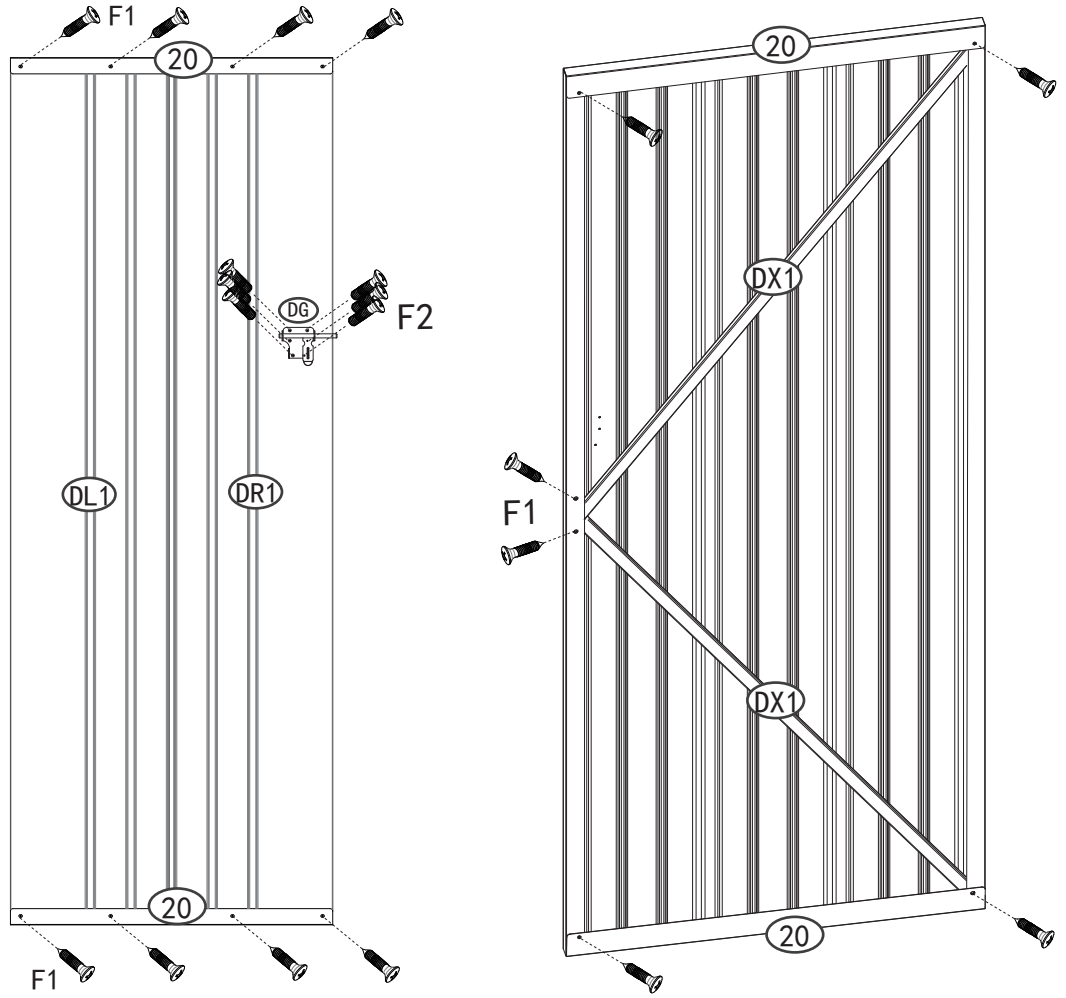

PART	NO.	Qty.
	DX1	2
	20	2
	DL1	1
	DR1	1
	DG	1
	F1	20
	F2	6





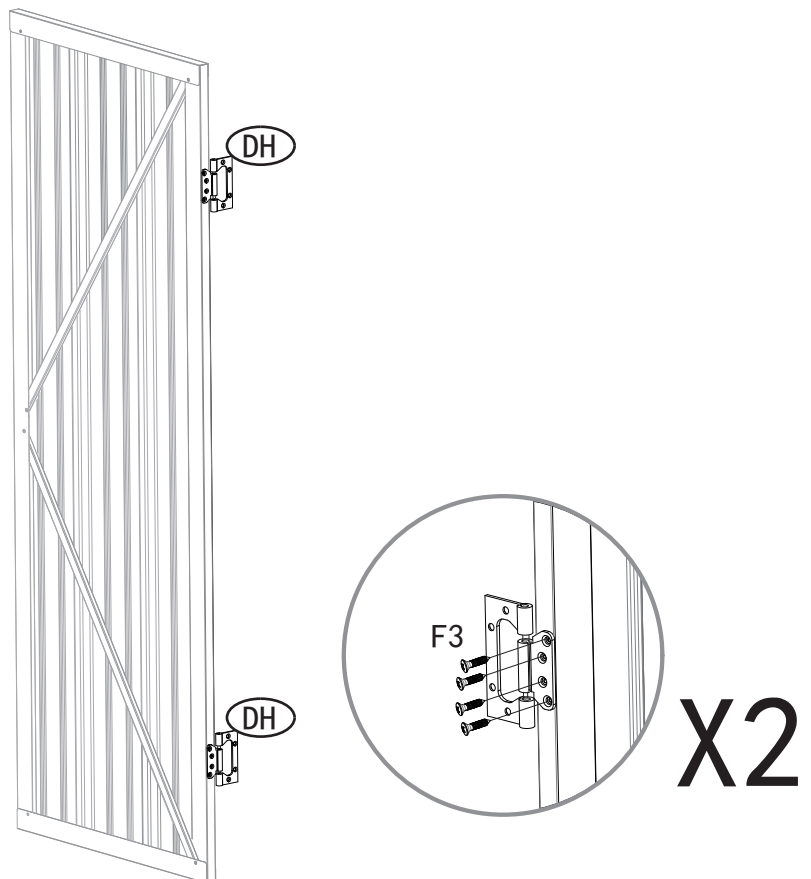

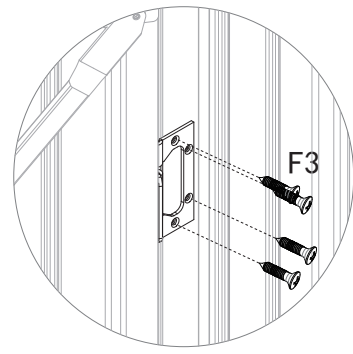
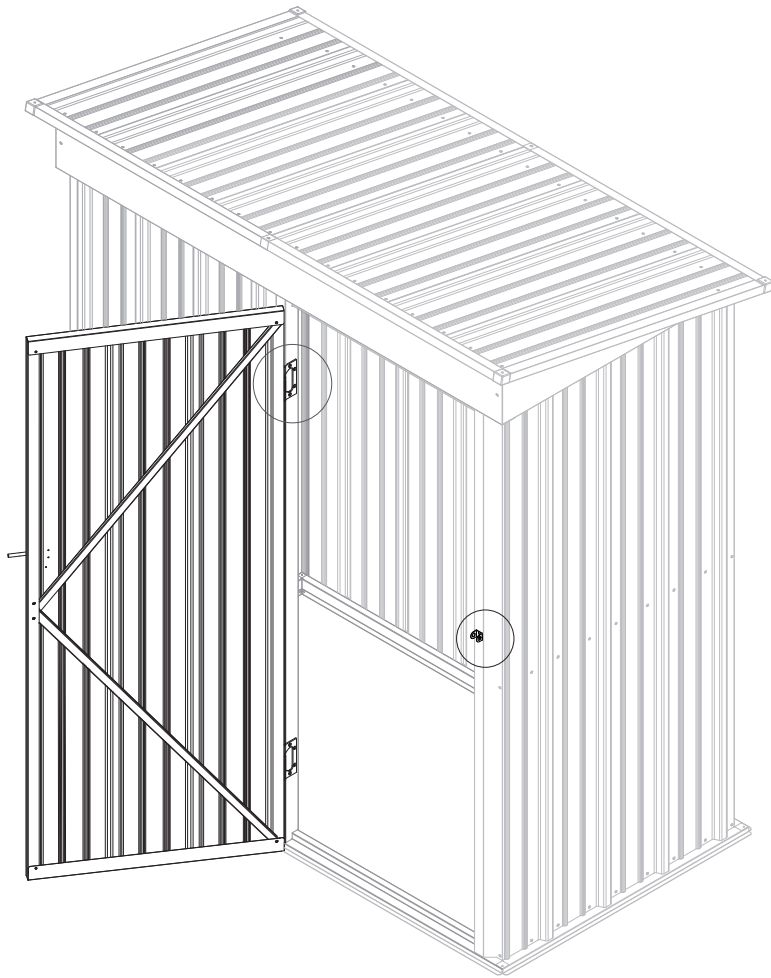
PART	NO.	Qty.
	DH	2
	F3	8



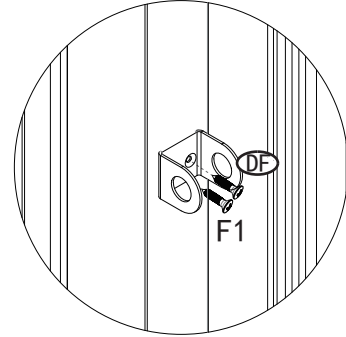

X2



PART	NO.	Qty.
	DF	1
	F3	8
	F1	2

PART	NO.	Qty.
	S1	122

