

ASSEMBLY INSTRUCTION

BENCH

A Seat Frame & Seat

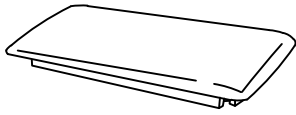

1 pc

B Leg

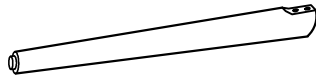

4 pcs

C Jcbc Bolt M6 x 60mm

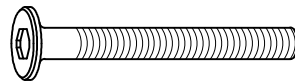

8 pcs

D Spring Washer M6



8 pcs

E Flat Washer



8 pcs

F Allen Key



1 pc



This page lists all the contents included in the box. Please take the time to identify the hardware as well as the individual components to this product. As you unpack and prepare for assembly, place the contents on a carpeted or padded area to protect them from damage.

1

Put the Seat Frame & Seat (A) upside down on the soft and smooth surface. Attach Leg (B) onto Seat Frame & Seat (A). Then insert Jcbc Bolt (C), Spring Washer (D) and Flat Washer (E) into holes of each Corner Block of Seat Frame & Seat (A), by using Allen Key (F). Do not fully tighten the bolts in this step.

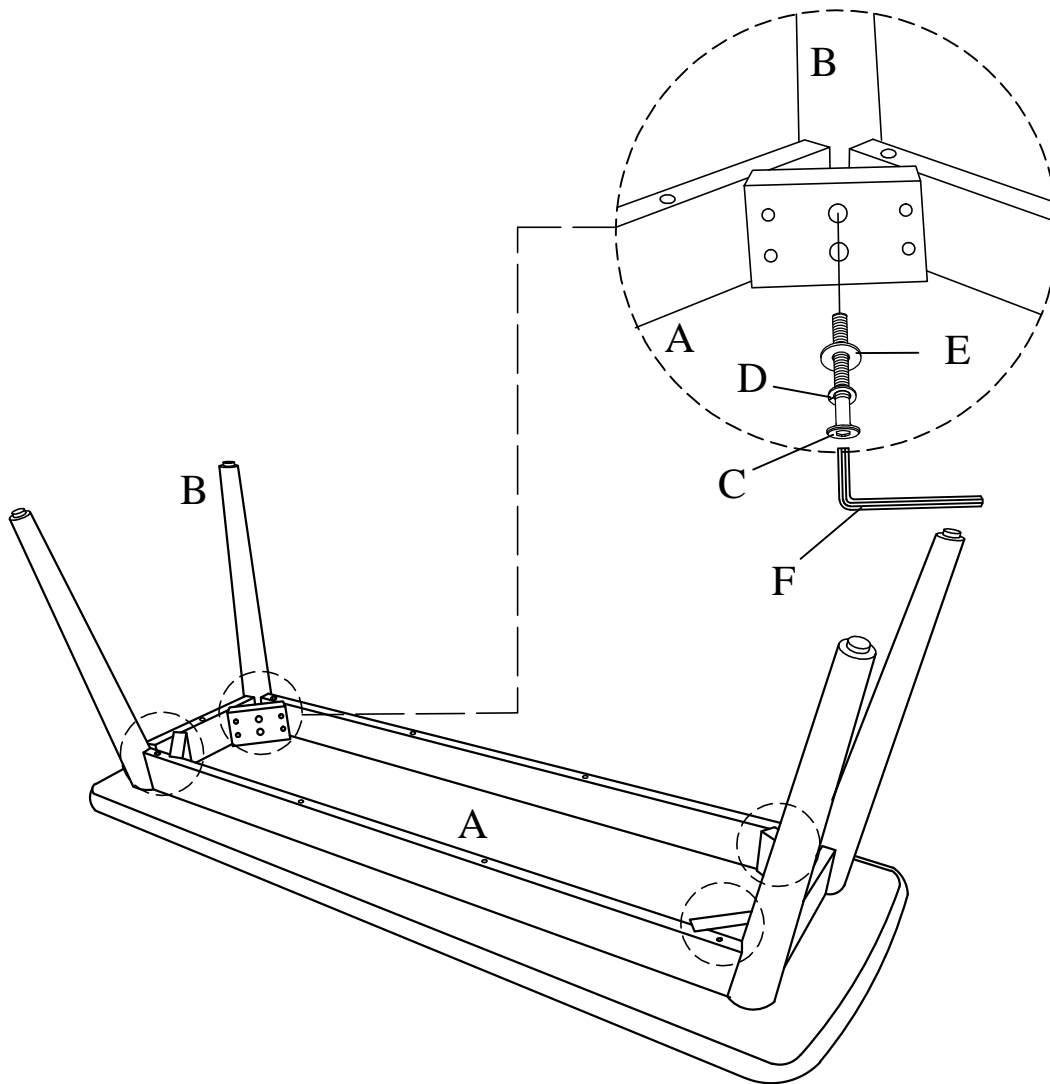

Stand chair up on an even surface and check that it is balanced. If there is a slight wobble, apply downward pressure in the corner where a leg is uneven. Keeping pressure in that corner, tighten all bolts. If balanced, apply downward pressure evenly in the center and tighten all bolts. Do not over-tighten beyond hole depth.

Helpful Tip:- Instead of applying downward pressure while reaching under to tighten bolts, have someone sit in the chair while you tighten the bolts.

Cleaning & Care

Treat surface with care. Surface is resistant to scratches but is not scratch resistant. Clean surface with a dry or damp soft cloth. Do not use abrasive cleaners. Hardware may loosen over time. Periodically check that all connections are tight.