

Assembly Instructions

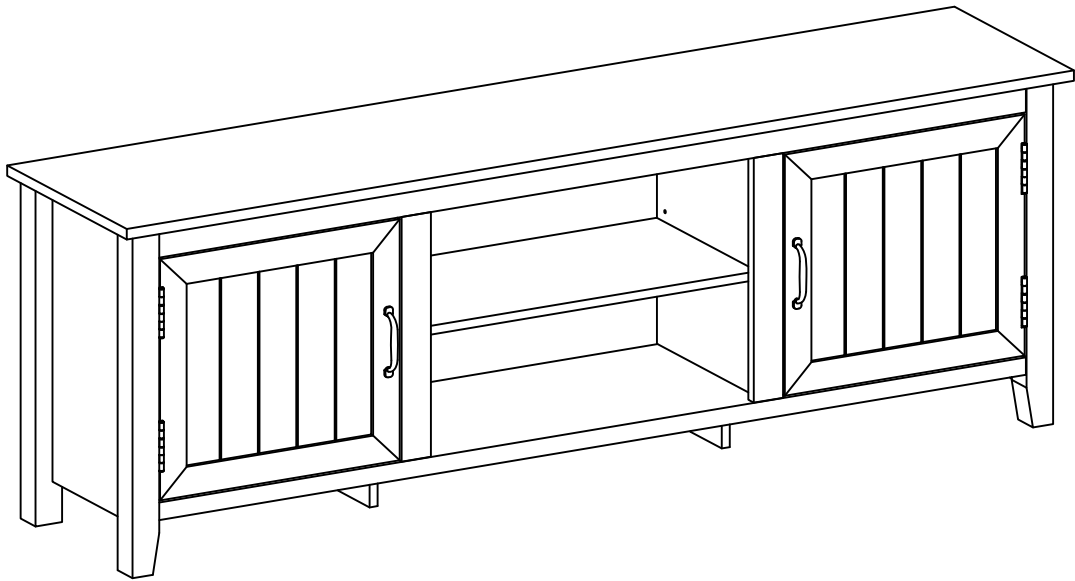

Please visit our website for the most current instructions, assembly tips, report damage, or request parts.

General Assembly Guidelines

- I. Ensure that all parts and hardware are available before beginning assembly.
- II. Follow each step carefully to ensure the proper assembly of this product.
- III. Two people are recommended for ease in the assembly of this product.
- IV. The three main types of hardware used to assemble this product are : wood dowels , screws and bolts.
- V. The provided glue is to secure wood dowels in place . When first inserting dowels , locate the appropriate hole for the dowel , place a small amount of glue in the hole and insert the dowel . Wipe away excess glue immediately.

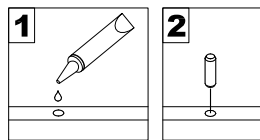

In future assembly steps when dowels are necessary to attach assembly parts together , place a small amount of glue on the end of the dowel before attaching parts together . Wipe away excess glue immediately.

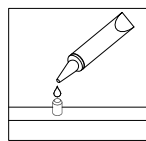

- VI. A Phillips head screwdriver is required for the assembly of this product .

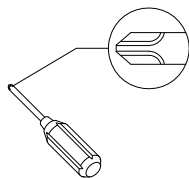



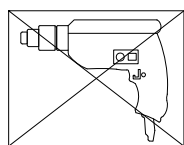



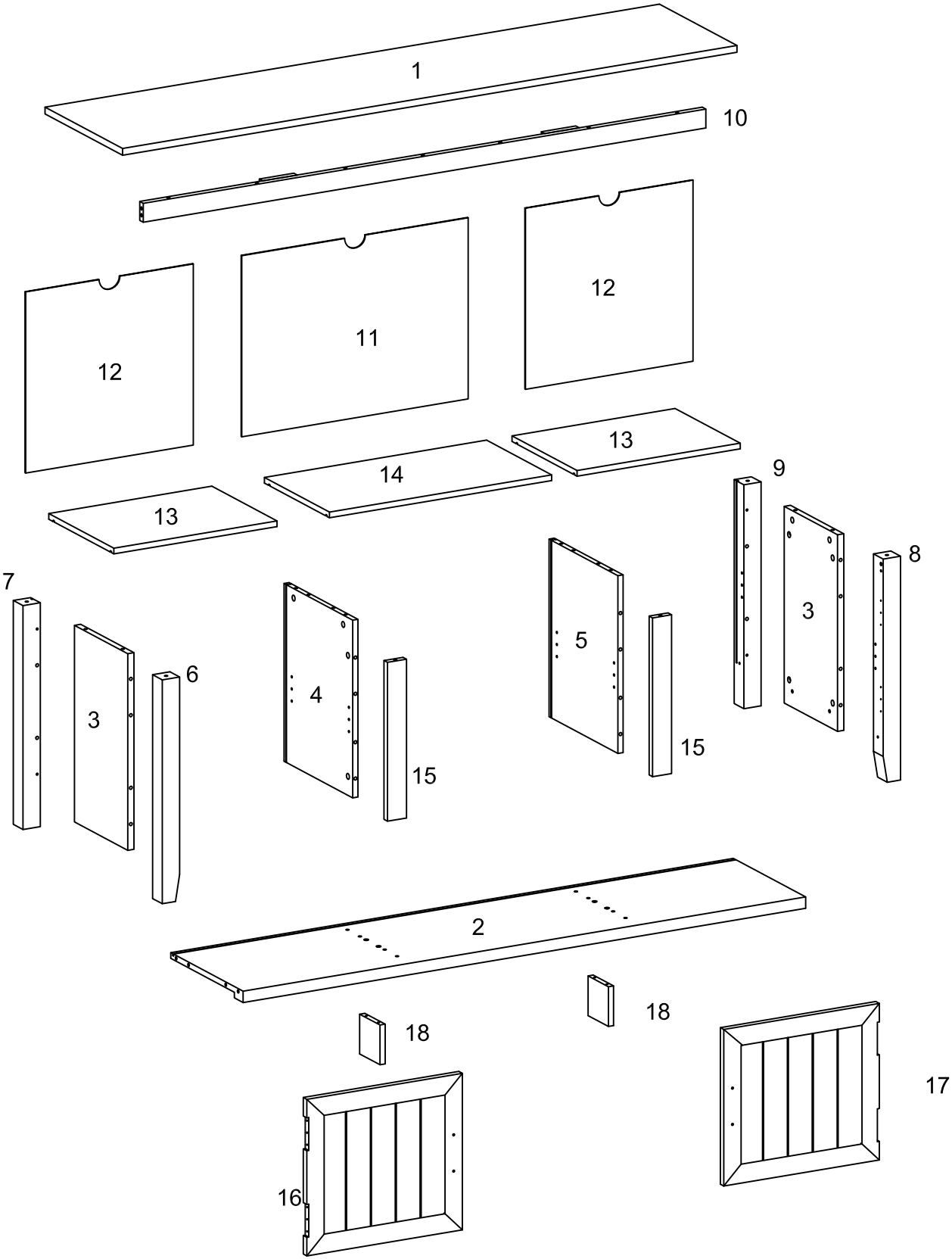







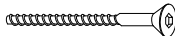

- VII. Power tools should not be used to assemble this product .

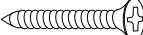
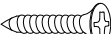

Parts List

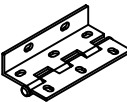

Hardware List

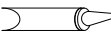
A		Ø8x30mm	Wooden dowel	35 pcs
B		Ø15x11mm	Cam lock	30 pcs
C		Ø6x35mm	Cam bolt	30 pcs
D		Ø30mm	Sticker	30 pcs
E			Plastic wedge	12 pcs
F		Ø3x17	screw	12 pcs
G		Ø6x50mm	Bolt	8 pcs
H		Ø5x16mm	Shelf support pin	12 pcs
I		Ø4x20	Screw	24 pcs
J		Ø4x15	Screw	8 pcs
K		Ø4x25	Bolt	4 pcs
L			Handle	2 pcs
M		30x20x1	Door plate	2 pcs
N			Hinge	4 pcs
O			Door stopper	2 pcs
P		Ø3x15	Screw	4 pcs
Q		Ø3x12	Screw	2 pcs
R		M 4	Hex key	1 pcs
S			Glue tube	1 pcs

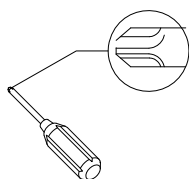

Philips head screwdriver required for assembly
(not included)

*The hardware quantities listed above are required for proper assembly.
Some extra hardware may also have been included.*

Step 1

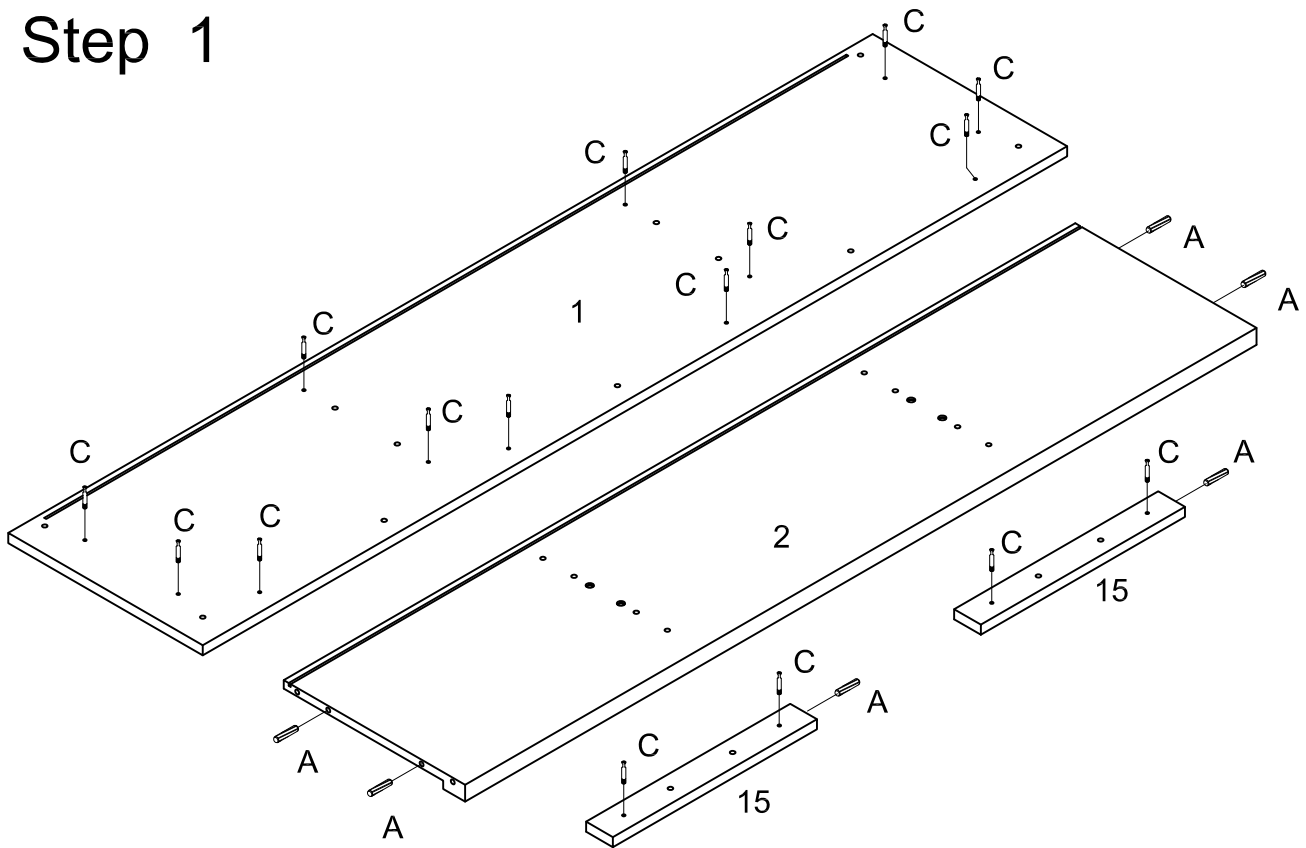

Insert wooden dowel (A) to part (2,15). Insert cam bolt (C) to part (1,15).

Step 2

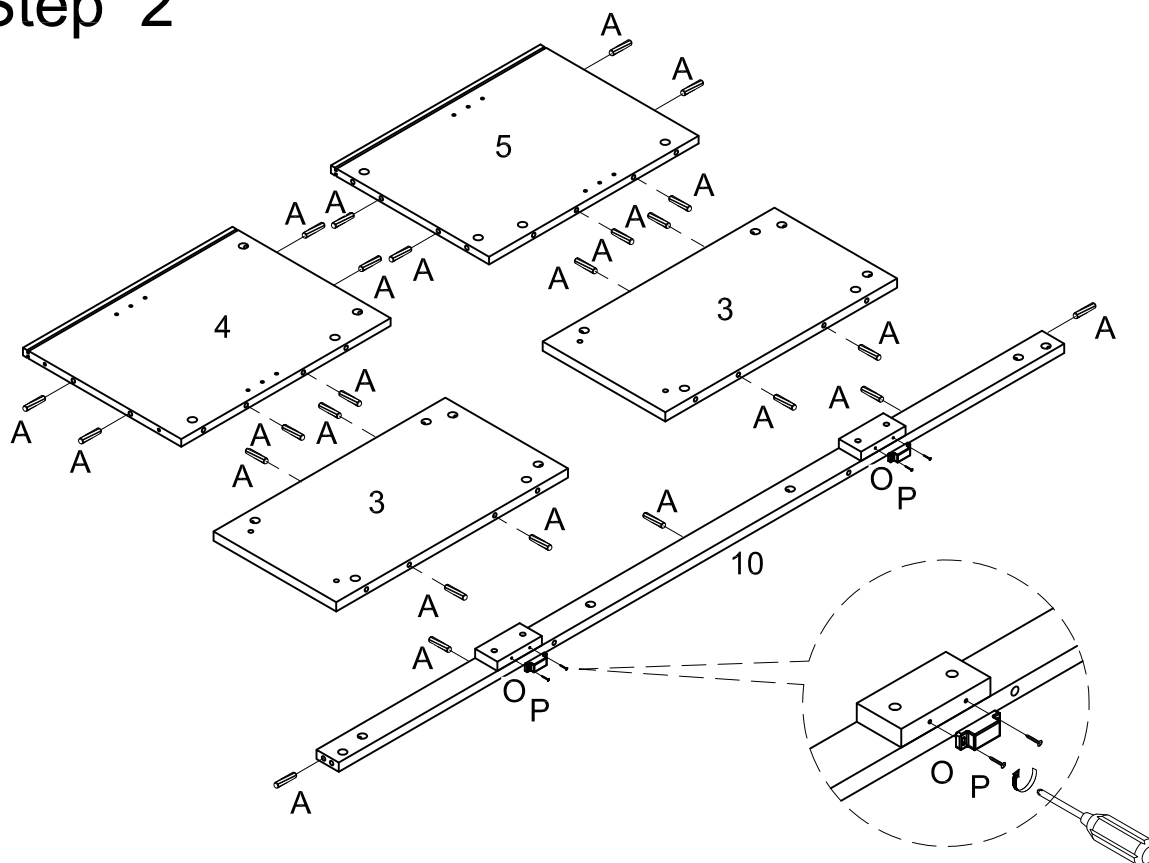

Insert wooden dowel (A) to part (3,4,5,10). Attach door stopper (O) to part (10) using screw (P) with screwdriver.

Step 3

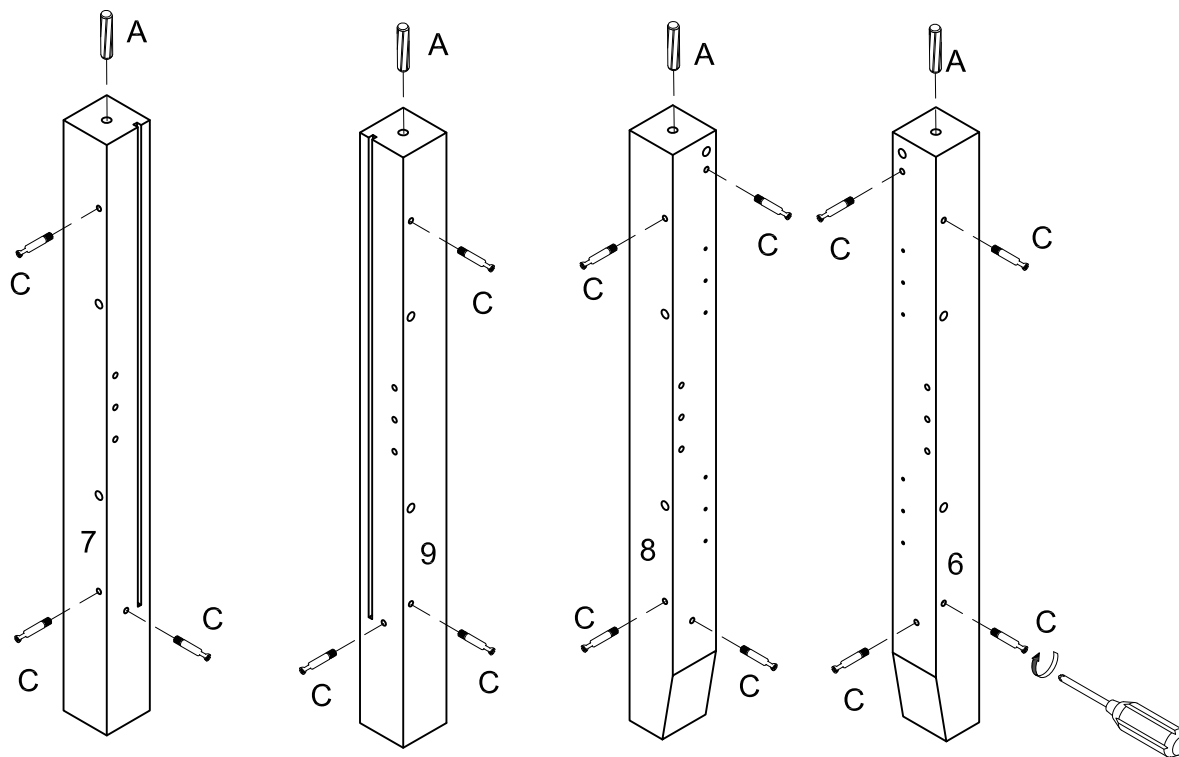

Insert wooden dowel (A) and cam bolt (C) to part (6,7,8,9).

Step 4

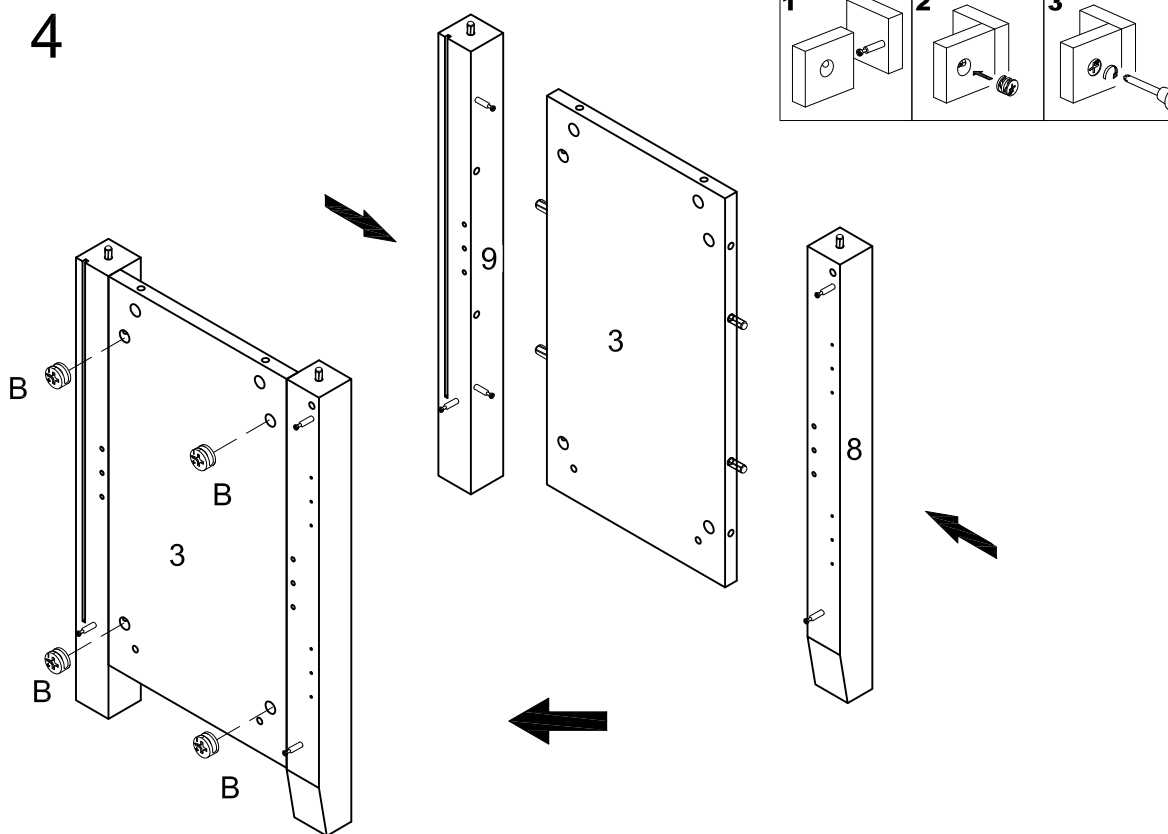

Attach part (8,9) to part (3), then insert and secure cam lock (B) to part (3) to lock it.

Step 5

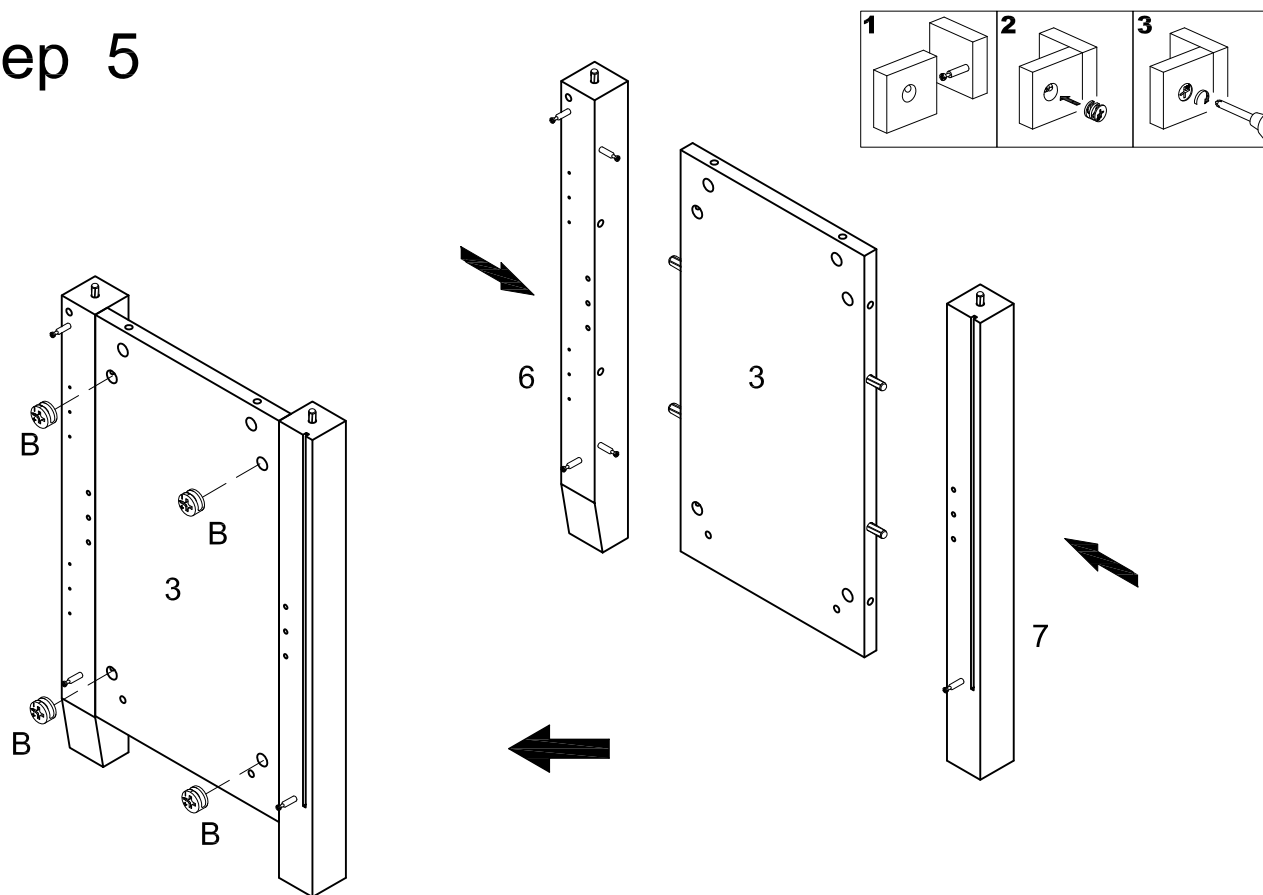

Attach part (6,7) to part (3), then insert and secure cam lock (B) to part (3) to lock it.

Step 6

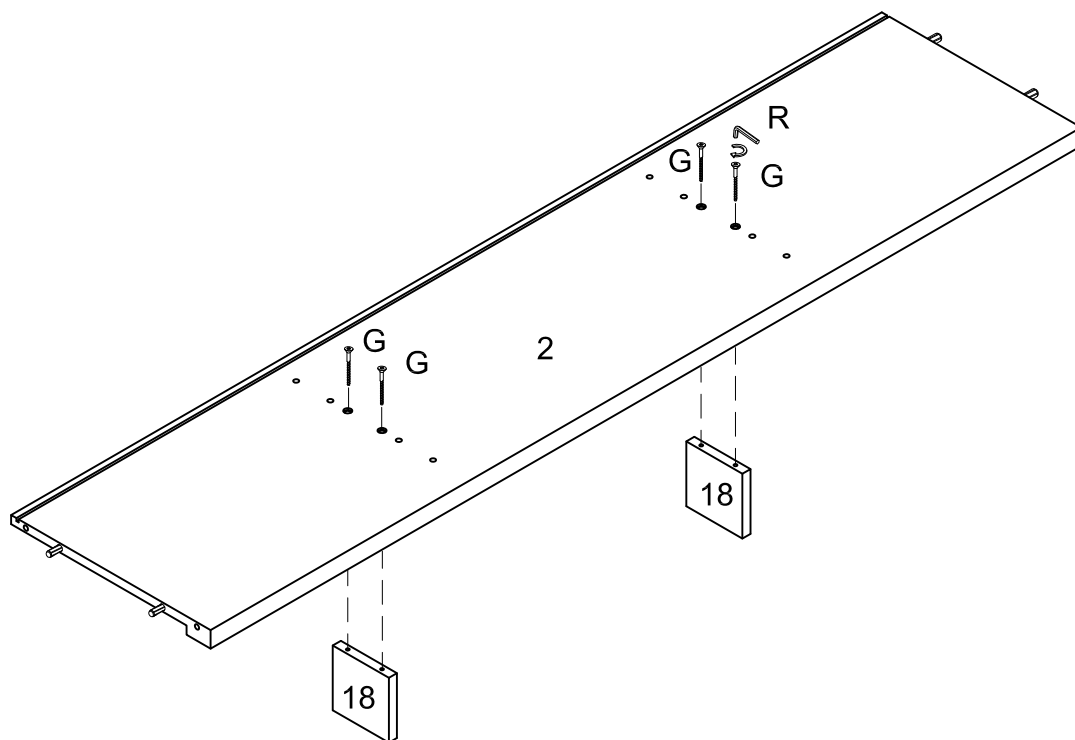

Attach part (18) to part (2) using bolt (G) with hex key (R).

Step 7

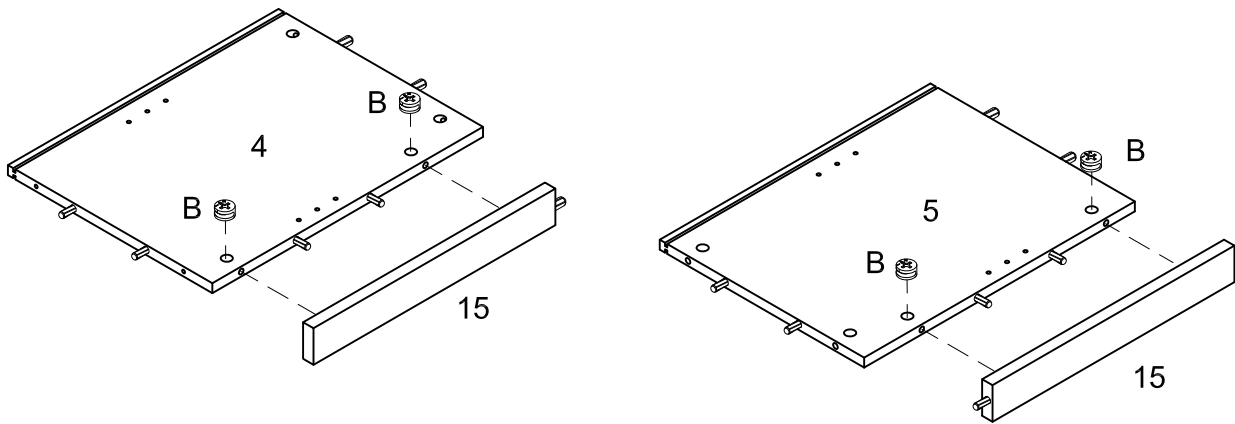
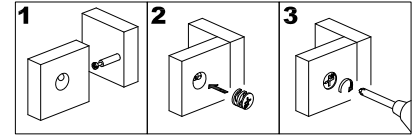

Attach part (15) to part (4,5), then insert and secure cam lock (B) to part (4,5) to lock it.

Step 8

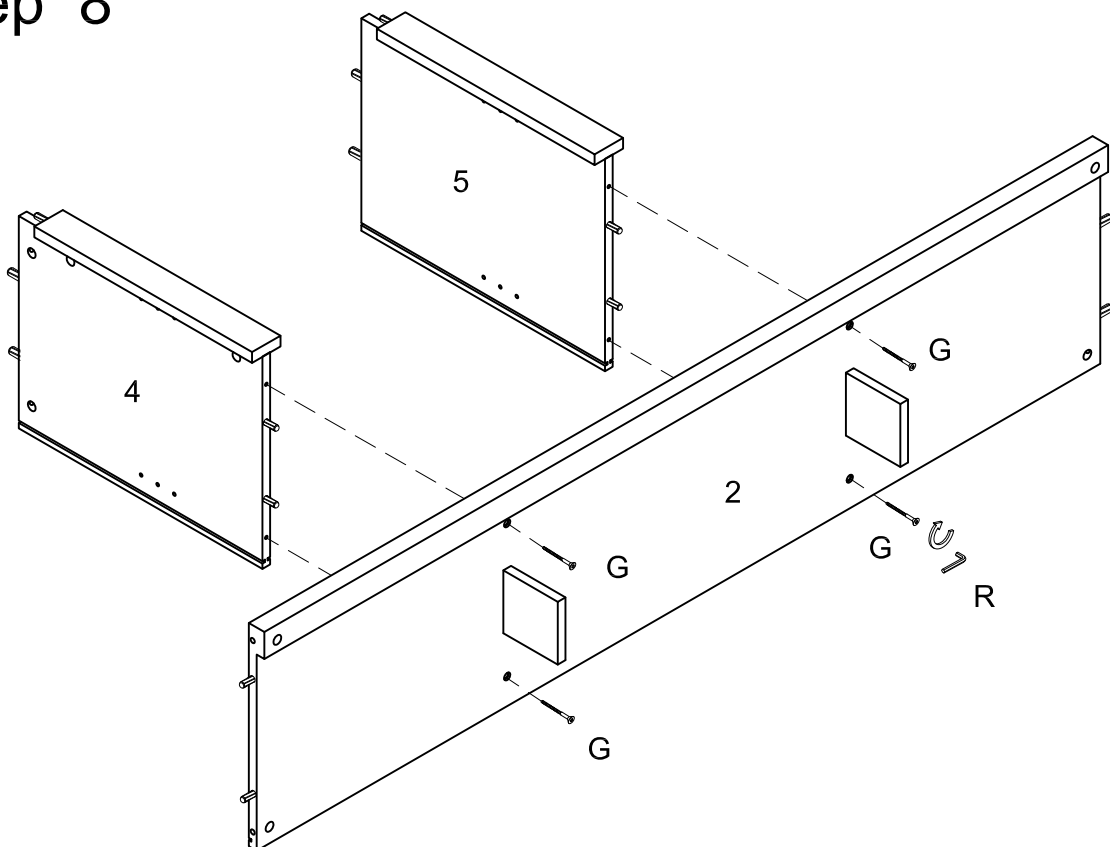

Attach part (4,5) to part (2) using bolt (G) with hex key (R).

Step 9

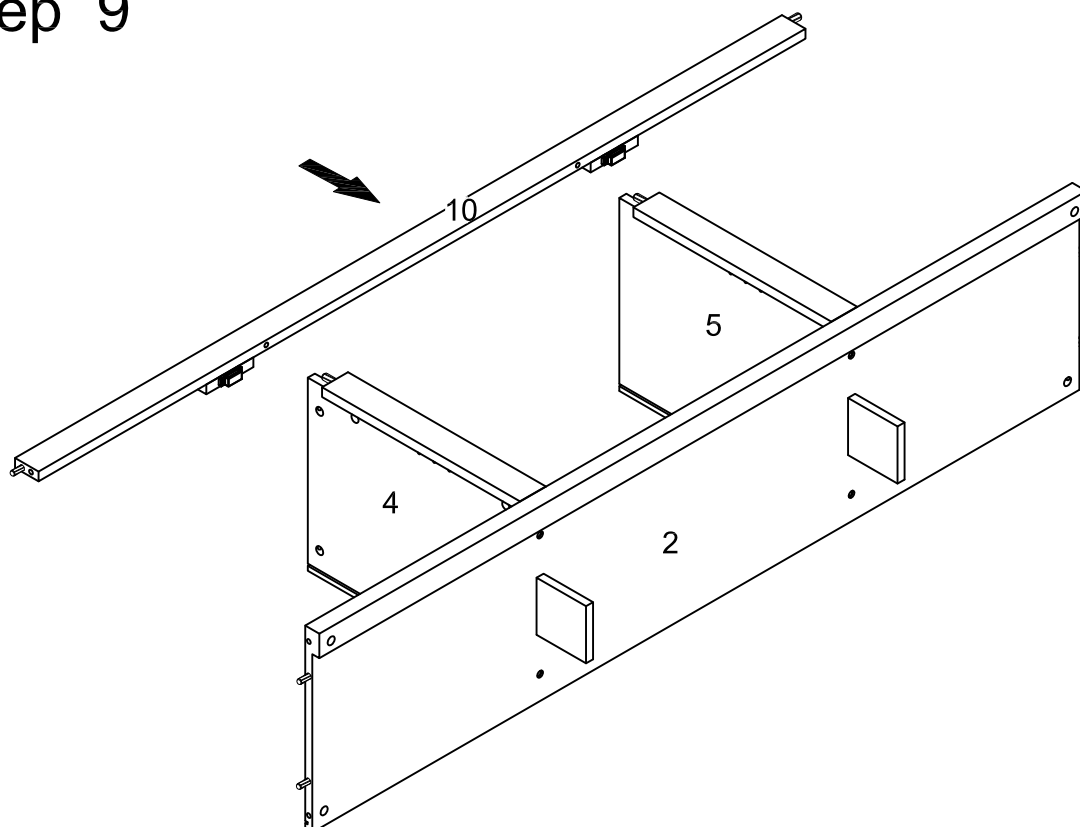

Attach part (10) to part (4,5).

Step 10

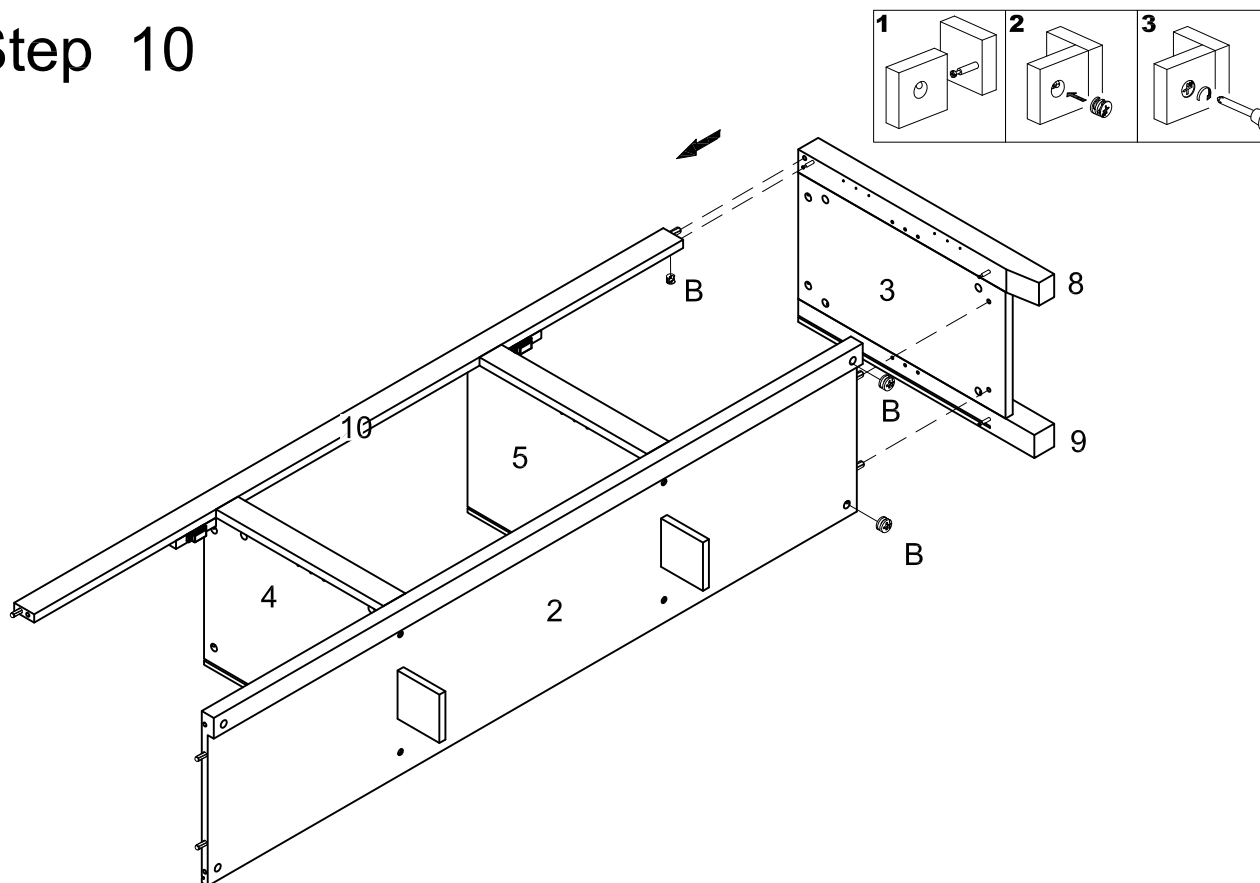

Attach part (8,9) to part (2,10), then insert and secure cam lock (B) to part (2,10) to lock it.

Step 11

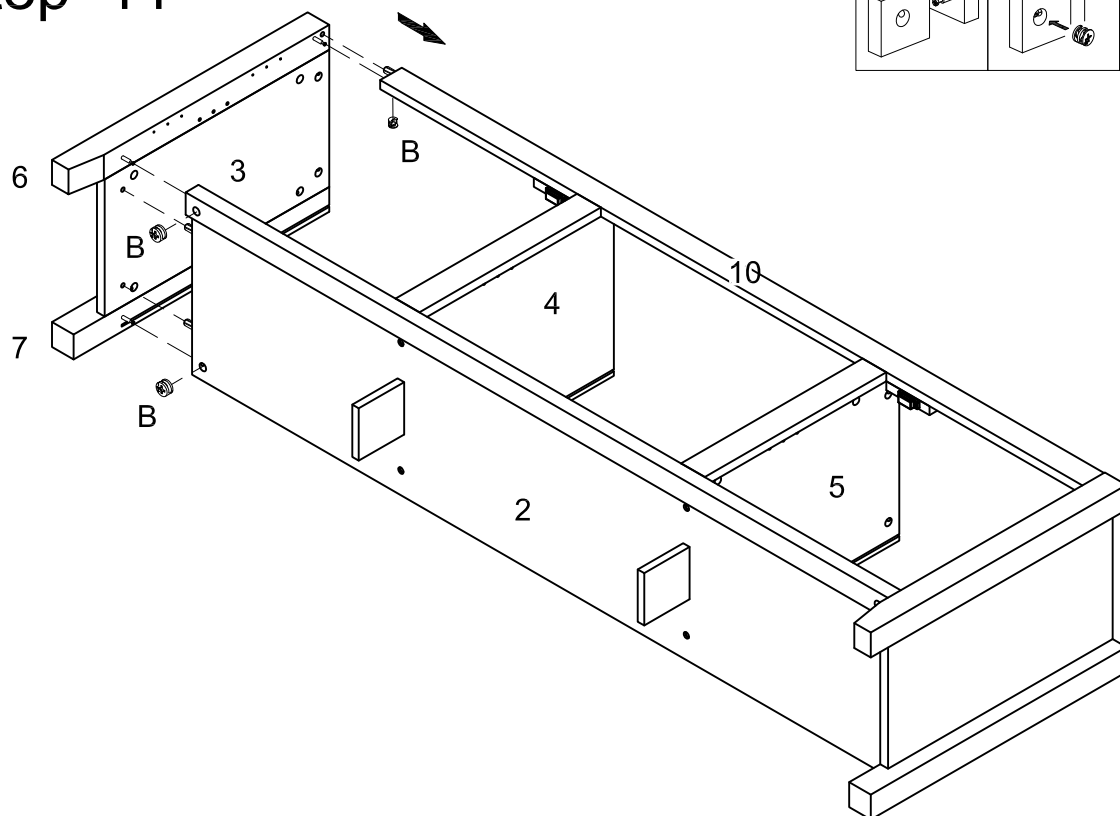

Attach part (6,7) to part (2,10), then insert and secure cam lock (B) to part (2,10) to lock it.

Step 12

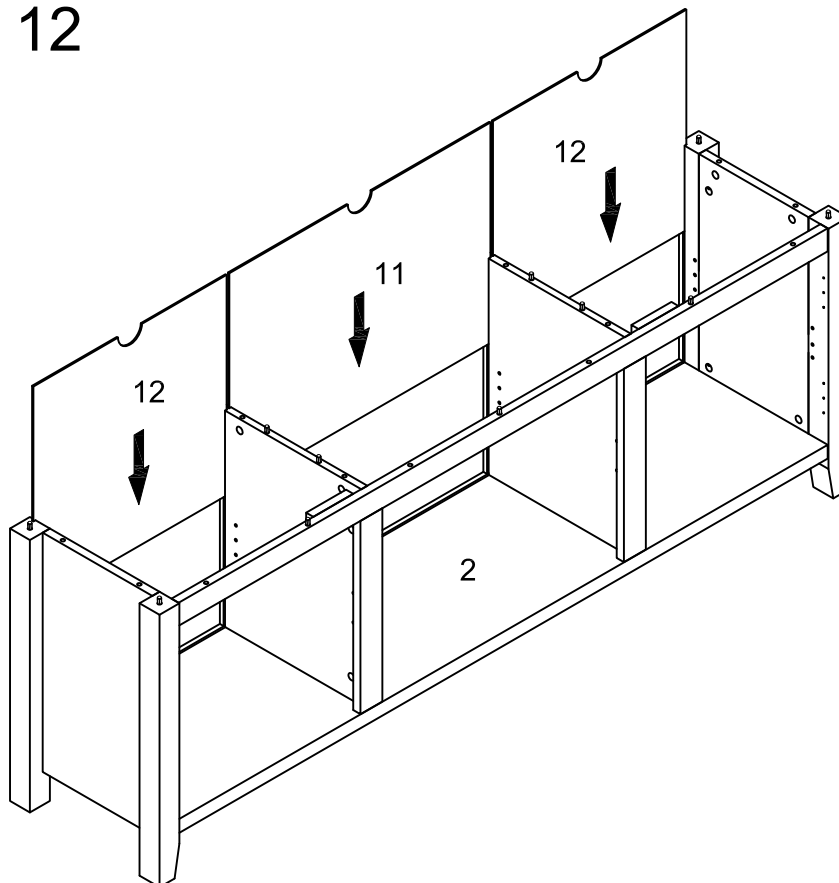

Slide back panel (11,12) into grooves as per diagram.

Step 13

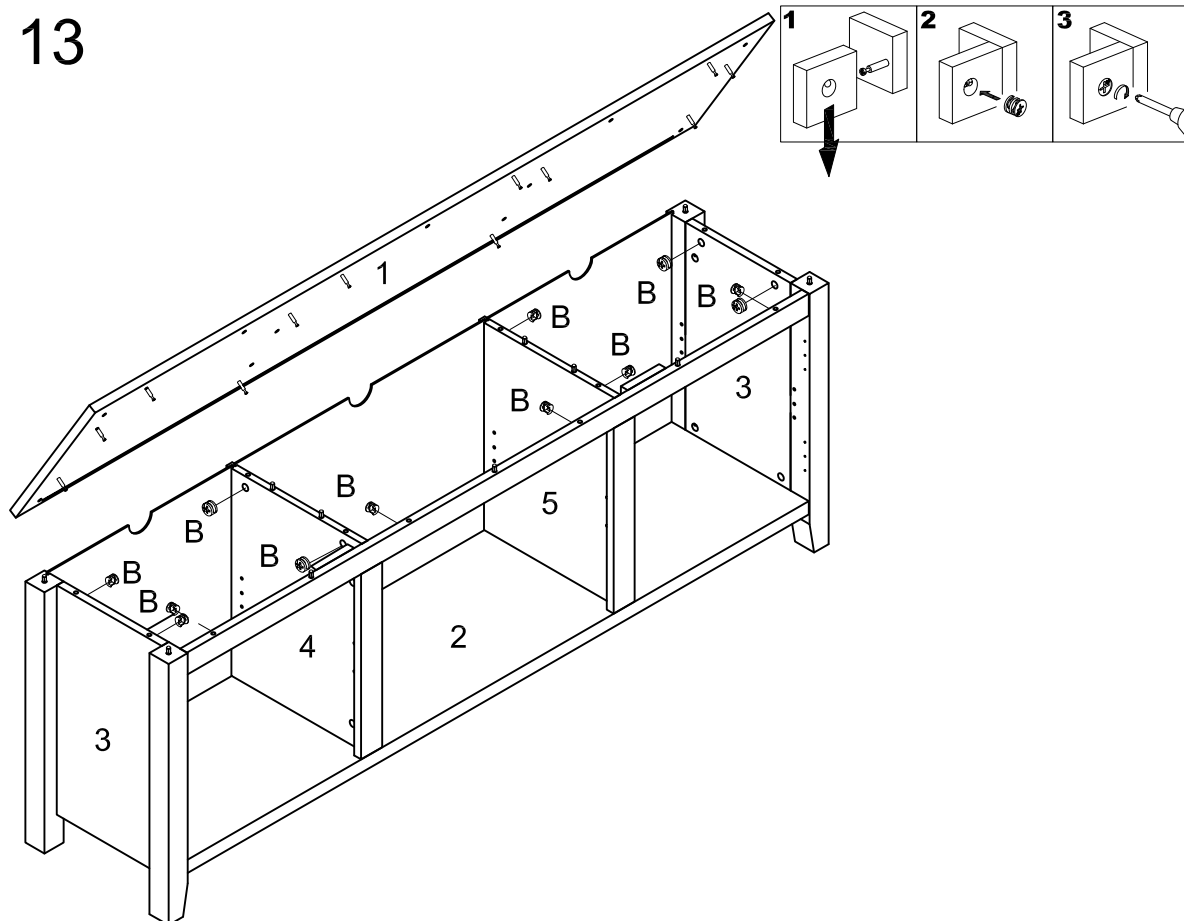

Attach part (1) to frame, then insert and secure cam lock (B) to frame to lock it.

Step 14

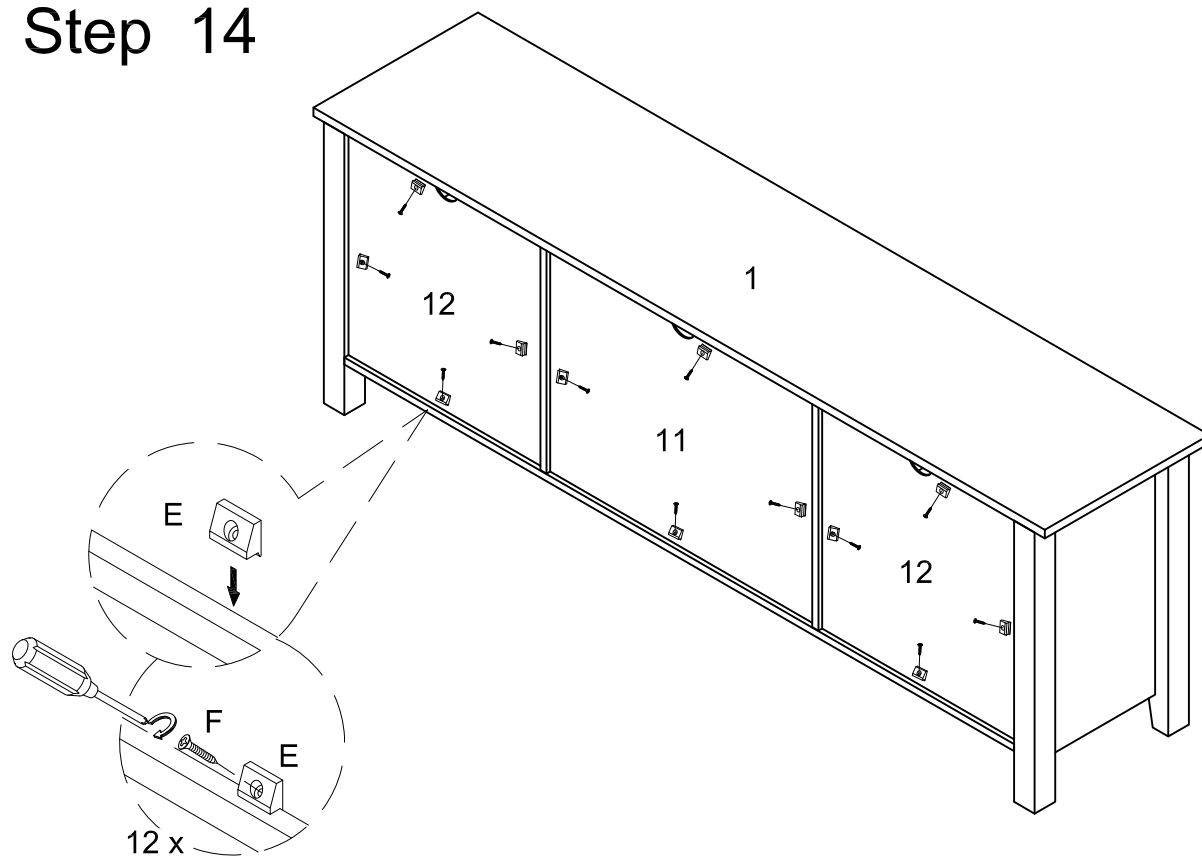

Attach plastic wedge (E) to part (11,12) using screw (F) with screwdriver.

Step 15

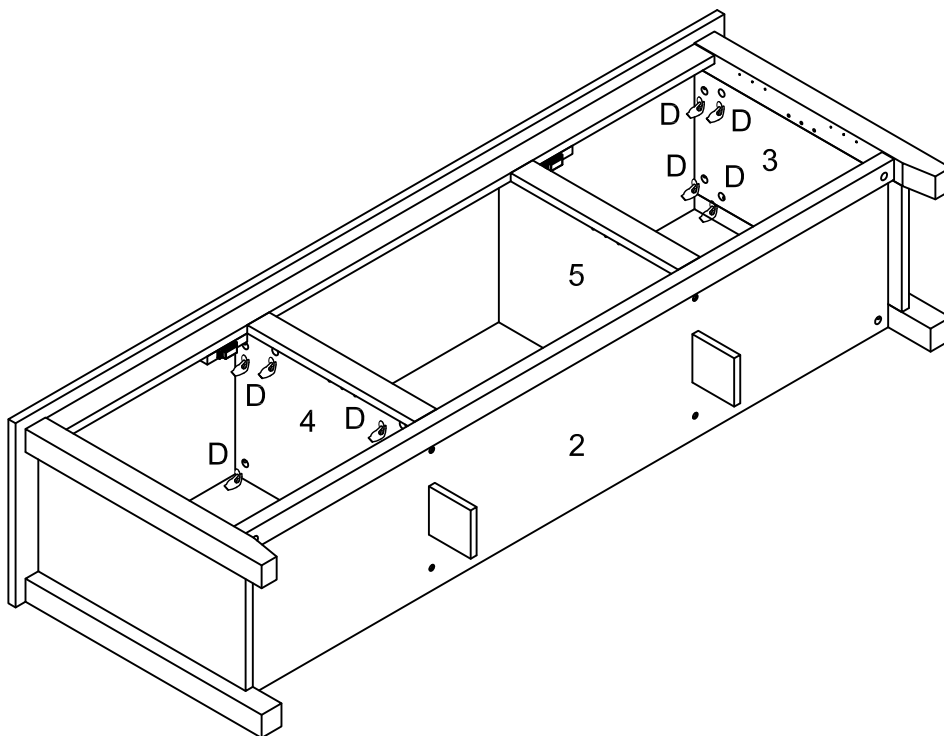

Place sticker (D) over holes as per diagram.

Step 16

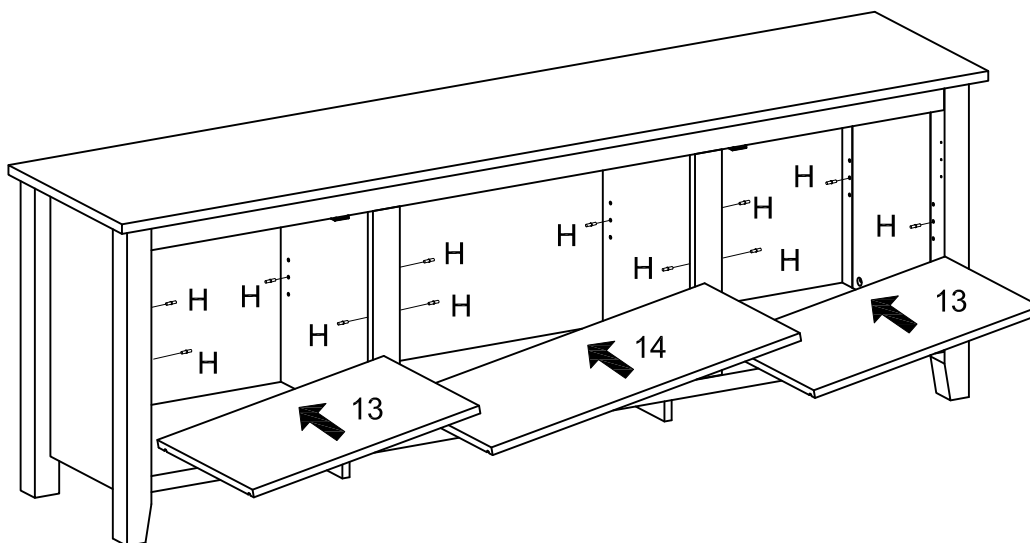

Insert shelf support pin (H) into side panel (3,4,5), then place part (13,14) on top of support pin (H).

Step 17

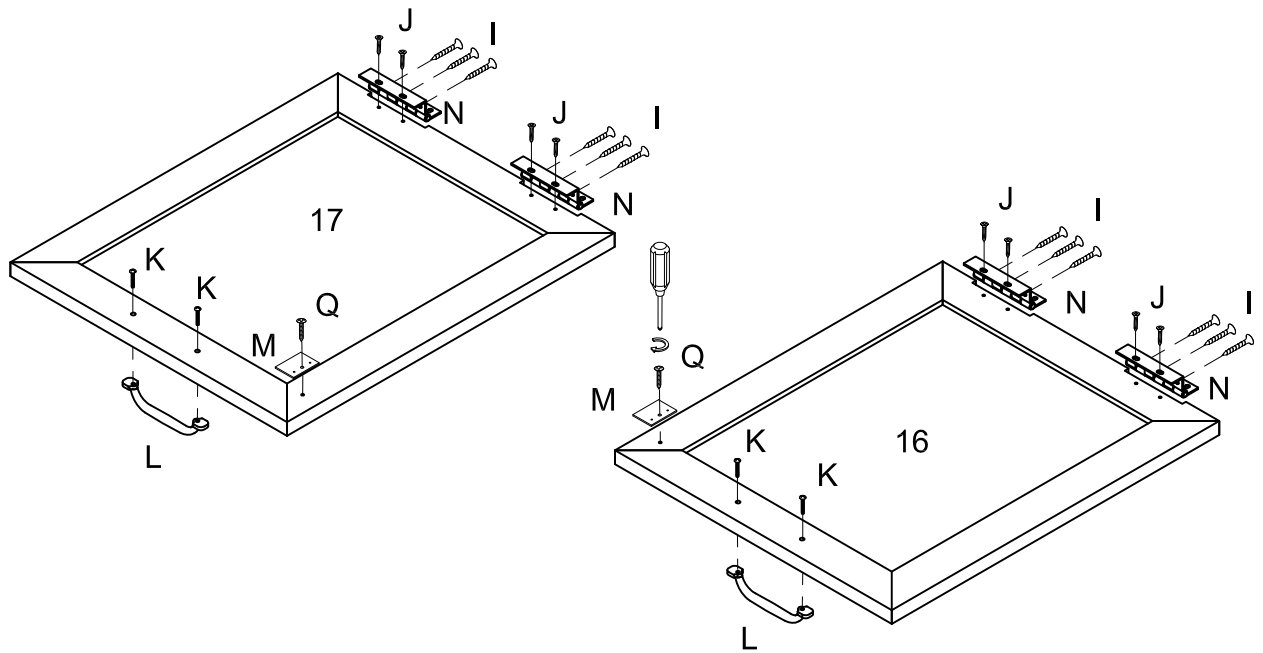

Attach hinge (N) to part (16,17) using screw (I,J), handle (L) using bolt (K), and door plate (M) using screw (Q) with screwdriver.

Step 18

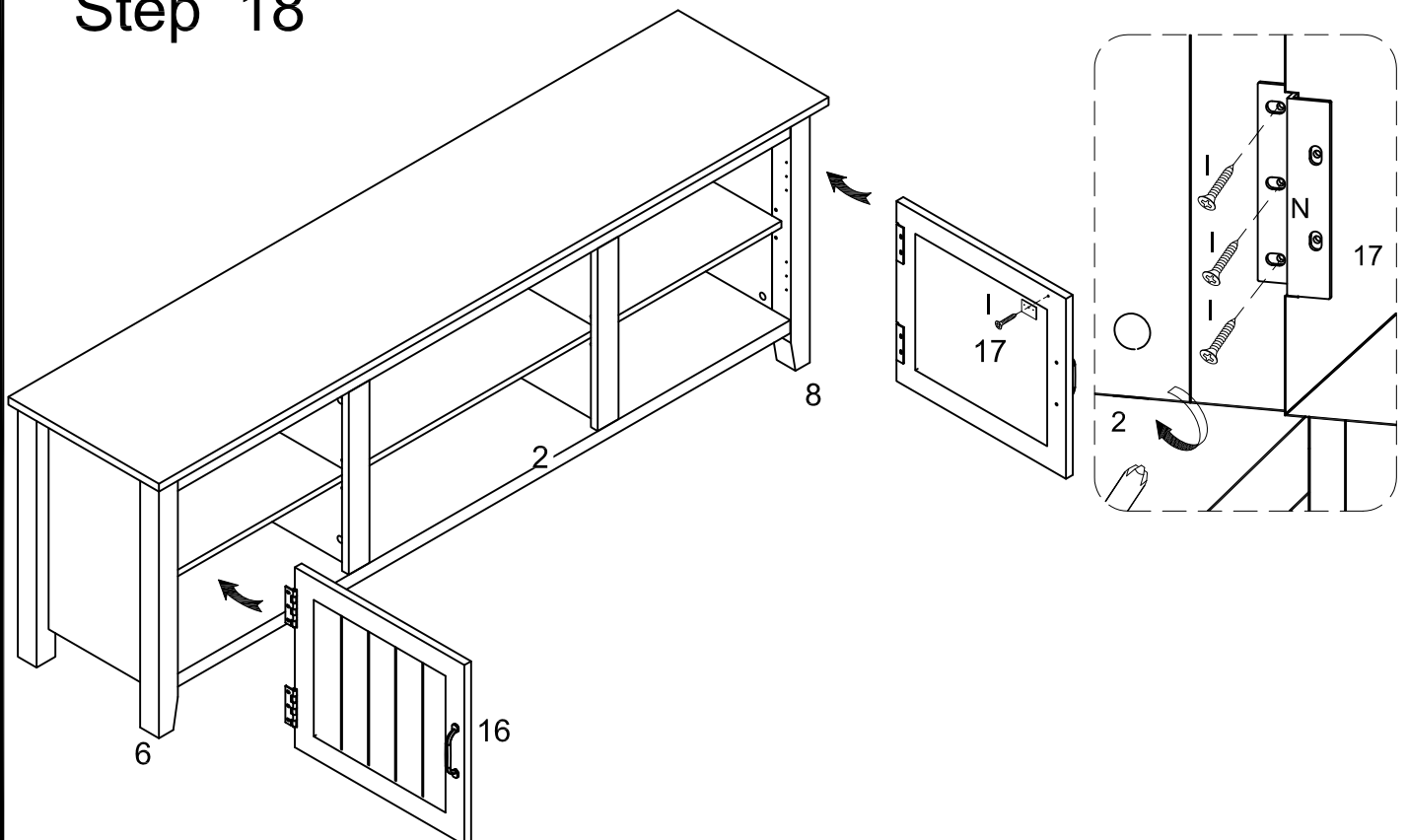

Attach part (16,17) to part (3) to secure hinge (N) using screw (I) with screwdriver.

Step 19

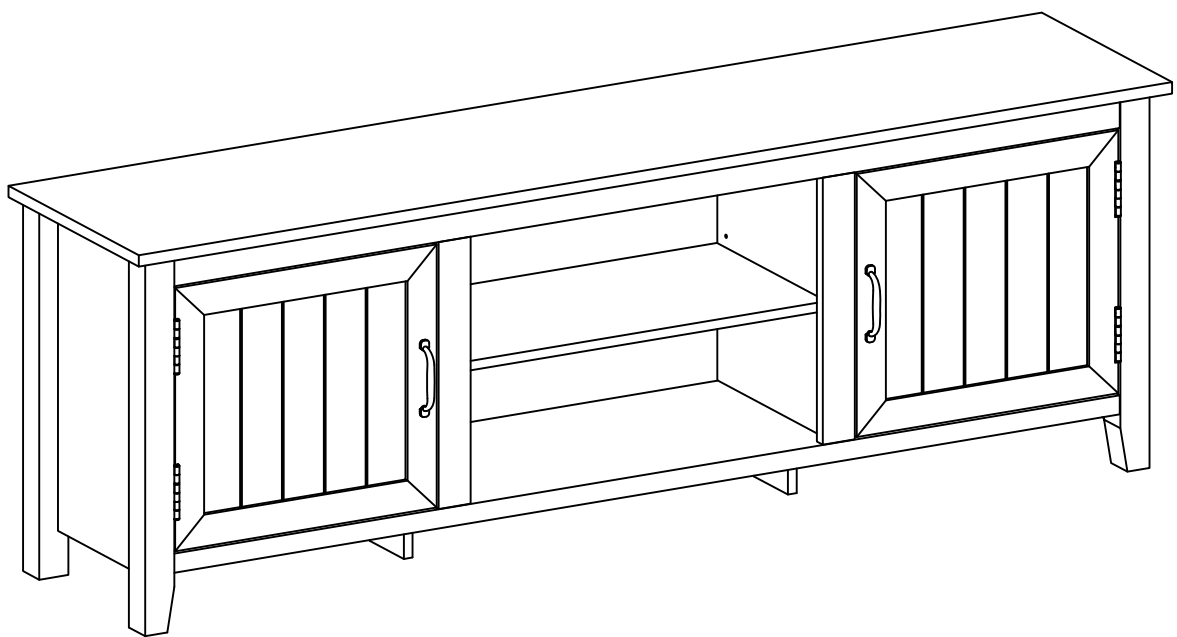

Final Assembly