

Kräus®

INSTALLATION GUIDE

Artec Pro™ Single Handle Commercial Kitchen Faucet

KPF-1603

Congratulations on the purchase of your new Kraus plumbing fixture!

Please keep the box and packaging materials until your product is completely installed. If you have any questions, require technical assistance, or have any problems with your product:



DO NOT RETURN TO STORE

Please contact our Customer Service Team

1-800-775-0703 / customerservice@kraususa.com

Have the model number available, and retain a copy of your receipt with purchase date for reference.

If for any reason this product does not meet your expectations, please be sure to repack this product in the original box and packaging material to avoid damage during transit.

Prior to Installation:

- Make sure you have all necessary parts by checking the diagram and parts list. If any part is missing or damaged, please contact Kraus Customer Service at 800-775-0703 for a replacement
- Turn off the hot and cold water lines at the angle stops and turn on the old faucet to release any built-up pressure
- Pre-drilled countertop hole size requirement: 1-3/8" (min)
- Max countertop thickness: 2"

Tools you will need:

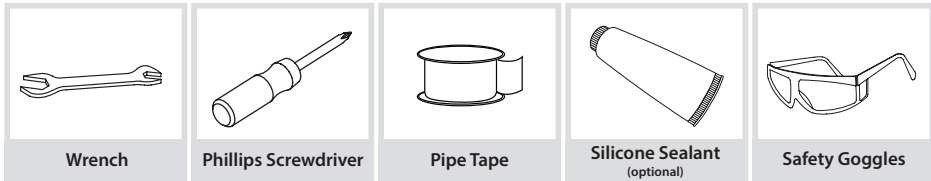
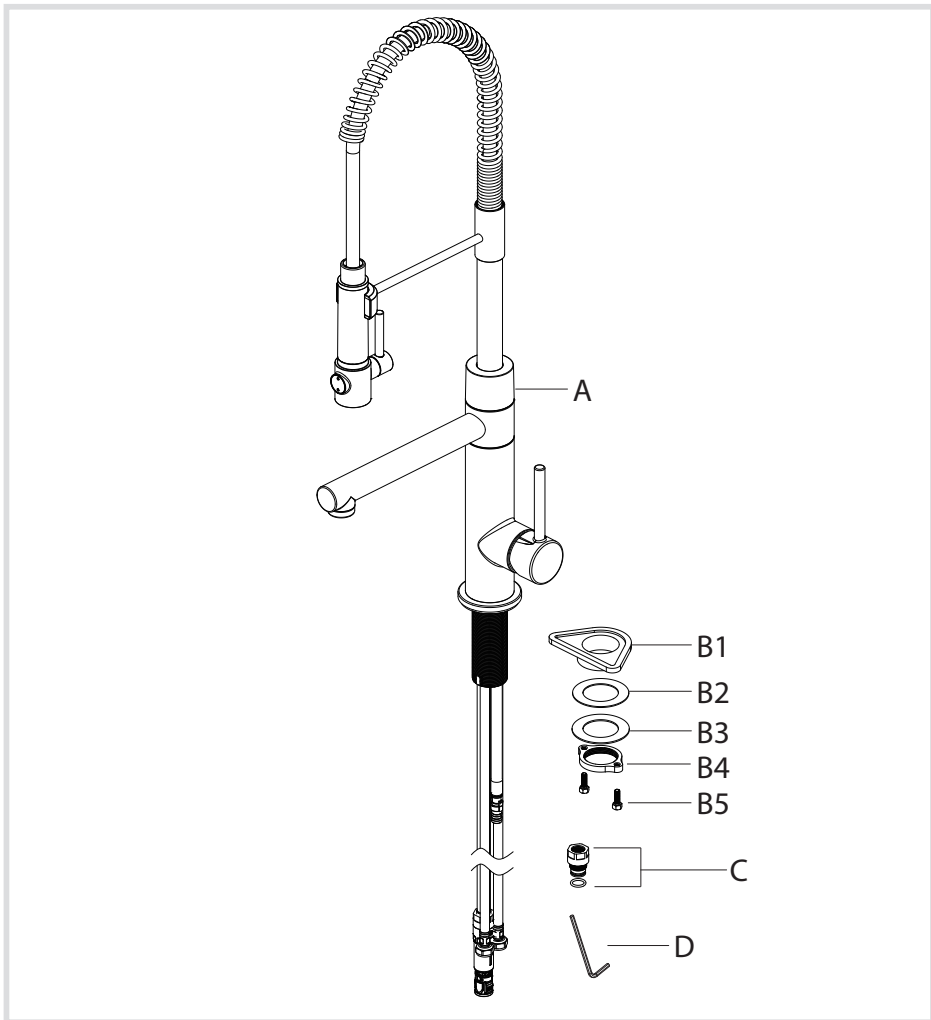

Diagram and Parts List



A. Faucet Body

B1. Seat

B2. Rubber Washer

B3. Metal Washer

B4. Mounting Nut

B5. Screw

C. 2.2 GPM Flow Restrictor

D. Hex Wrench

Faucet Dimension

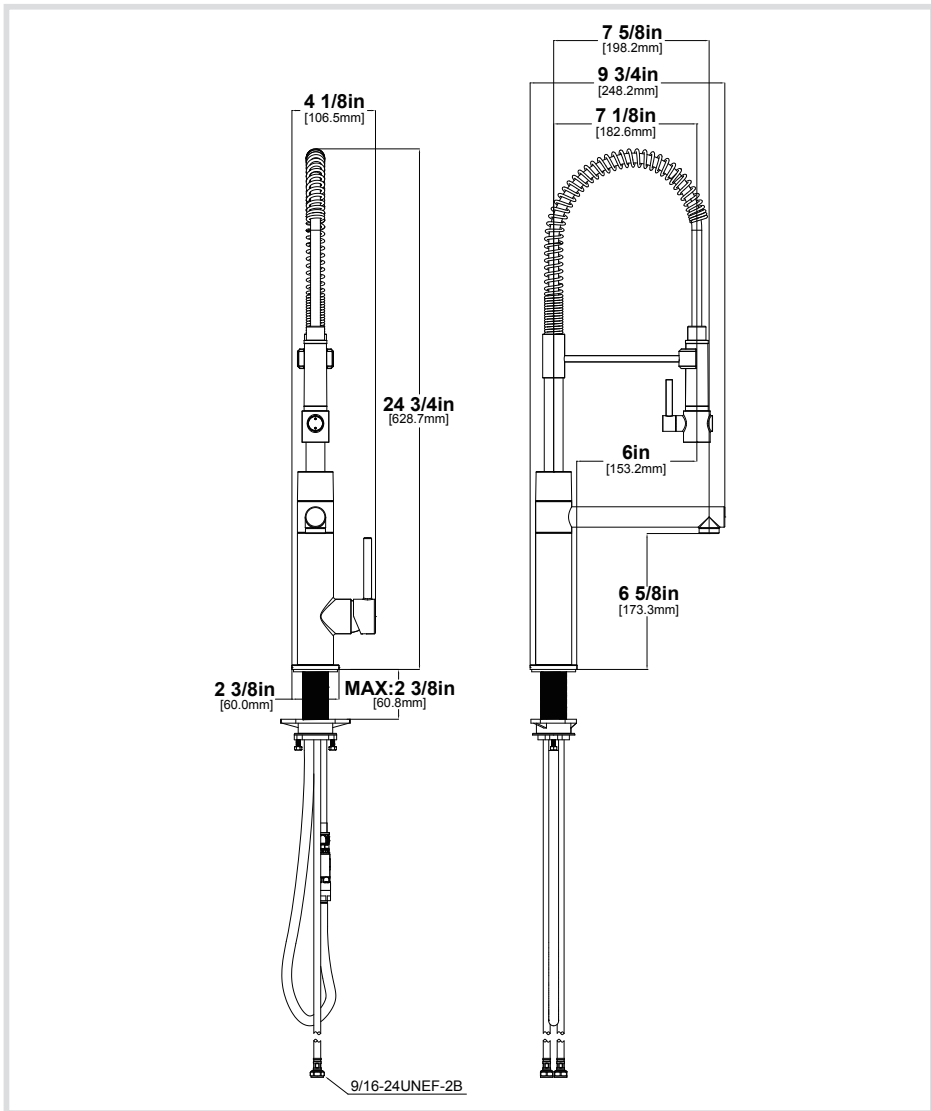

Installer Tip:

Shut off main water supply before installing new faucet

Step 1: Remove washer and lock nut

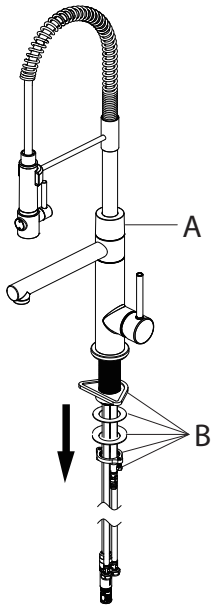

Shut off the water supply. Remove the old faucet. Clean the mounting surface. Remove mounting hardware (B) from faucet body (A).

Step 2: Install faucet

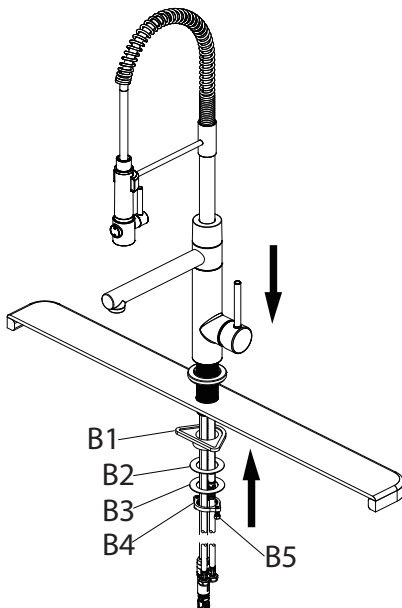

Insert faucet through hole in sink or countertop. From underneath sink, attach the seat (B1), rubber washer (B2), metal washer (B3), and nut (B4). Lock nut (B4) into position by tightening screws (B5).

Step 3: Making the water supply connections

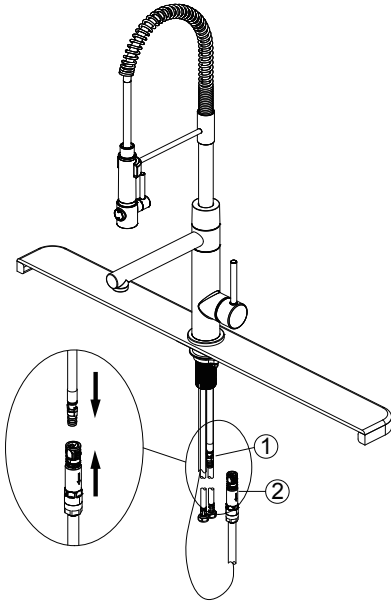

Push the quick connector (2) firmly upward and attach it to the receiving block (1). Pull down moderately to ensure the connection has been made.

If it is necessary to remove the quick connector (2), squeeze the tabs on the hose and then pull down to disconnect.

Step 4: Making the water supply connections

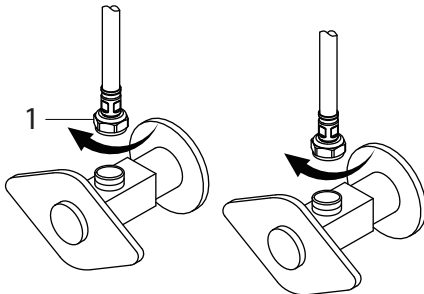

Thread the nut (1) on the supply line onto the outlet of the water supply valve and tighten with a wrench. Do not overtighten.

Step 5: Flushing and checking for leaks

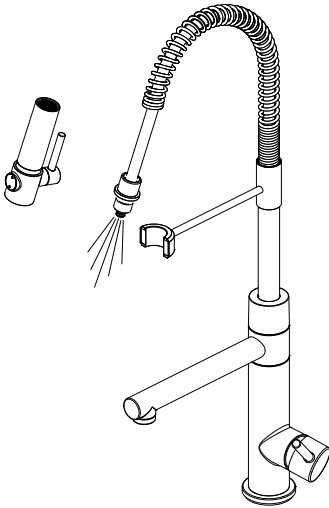

Pull the hose assembly out of the spout and remove the spray head by unscrewing it from the hose in a counterclockwise direction. Be sure to hold the end of the hose down into the sink and turn the faucet on to the warm position where it mixes hot and cold water.

Flush the water lines for one minute. This flushes away any debris that could cause damage to internal parts. Check for leaks.

Reinstall the spray head by hand tightening it back onto the spray hose.

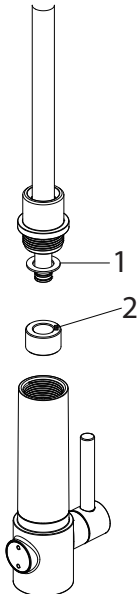

NOTE:

1. Do not lose the rubber washer (1) when installing back the sprayer
2. The magnet end marking with black dot should be toward the hose for correct magnet installation

Step 6: Flush faucet

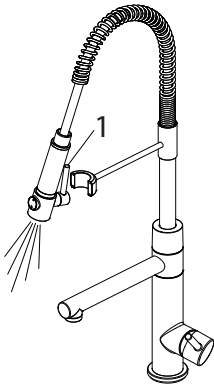

To activate the spray mode, simply press the handle (1) located under the spray head.

Step 7: Flow Regulator Replacement

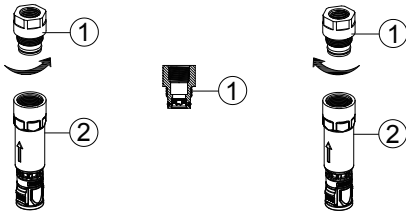

This faucet ships with a 1.8 GPM flow restrictor installed. An optional 2.2 GPM flow restrictor is also included in the box.

To switch the flow rate of the faucet:

1. Disassemble the quick connect assembly by separating the connector (1) and quick connect (2).
2. Replace 1.8 GPM connector (blue) with the 2.2 GPM connector.
3. Reinstall the quick connect assembly.

NOTE: In compliance with CEC standards, this faucet is designed with a 1.8 gpm flow rate. At your discretion, you may modify the product with the included 2.2 gpm restrictor. Please note that doing so will remove the capability of this product to meet specific low-flow standards. Kraus is not liable for any alterations made to the product post-sale, and highly advises that you consult with your local or statewide plumbing enforcement agency prior to any modification.

Replacement Parts

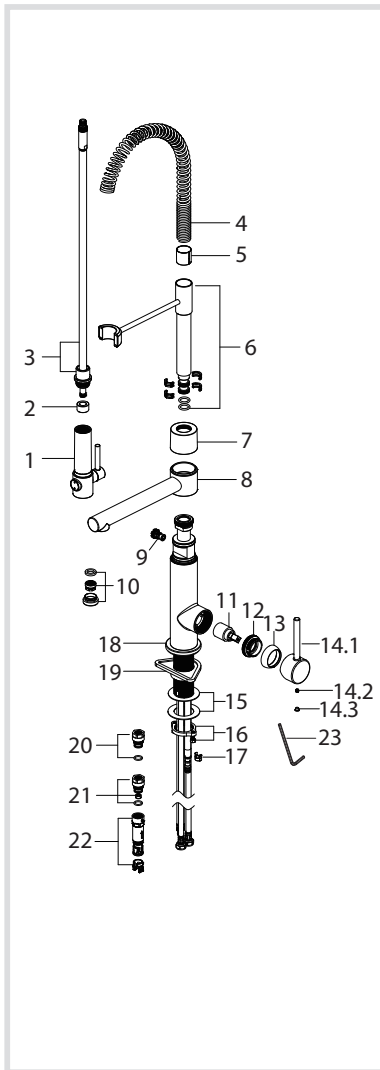

Replacement Parts List	Finish	Part NO
1. Spray head	CH, SFS, SFSMB	KP27060
2. Magnet		KP27061
3. Spray hose assembly	BLBG, BLSFS, GRCH, GRSFS*	KP27062
4. Spring	CH, SFS, BG	KP27063
5. Inverter		KP27080
6. Spray support assembly	CH, SFS, BG	KP27064
7. Spout nut	CH, SFS, BG, MB	KP27065
8. Spout	CH, SFS, BG, MB	KP27066
9. Diverter		KP27067
10. Aerator assembly	CH, SFS, BG, MB	KP27068
11. Cartridge		KP27069
12. Bonnet nut		KP27070
13. Cap	CH, SFS, BG	KP27071
14. Handle assembly	CH, SFS, BG	KP27072
15. Rubber & metal washer		KP27028
16. Mounting nut & nut		KP27079
17. Block		KP27073
18. Flange	CH, SFS, BG	KP27077
19. Seat		KP27078
20. 2.2GPM flow restrictor		KP27075
21. 1.8GPM flow restrictor		KP27074
22. Quick connect		KP27076
23. Hex wrench		KP27020

*Spray hose assembly color options: Black hose w/ Brushed Gold connector (BLBG), Black hose with Spot-Free Stainless connector (BLSFS), Gray hose with Chrome connector (GRCH), Gray hose with Spot-Free Stainless connector (GRSFS)

Trouble - Shooting

If you have followed the instructions carefully and your faucet still does not work properly, take the following corrective steps:

PROBLEM	CAUSE	ACTION
Leakage under the handle	Bonnet nut (12) has come loose	Remove the index (14.3). Loosen set screw (14.2) with hex wrench (14). Remove the handle (14.1). Unscrew cap (13) (by hand only). Tighten bonnet nut (12) with an adjustable wrench
The aerator has an irregular or reduced water flow	The aerator is dirty or mis-fitted	Remove the aerator and check for debris. Ensure that the rubber washer is properly installed.
The water pressure is low.	The connector underneath the deck is clogged with debris The aerator is clogged	Turn off the water supply and disconnect the connector / aerator. Unscrew the connector / aerator and clean under running water. Screw the connector / aerator back. Test water flow. If water pressure is still low then replace the connector / aerator.

Care & Maintenance

*To keep the product clean & shining, follow the steps below:

1. Rinse with clean water & dry with a soft cloth
2. Do not clean with soaps, acid, polish, abrasives, or harsh cleaners
3. Do not use cloth with a coarse surface
4. Unscrew the aerator and clean when necessary

*This installation manual is subject to change without further notice.



Codes/Standards Applicable:



ASME A112.18.1
1.8GPM 6.8L/min maximum

Faucet Warranty

Kraus products are manufactured and tested to the highest quality standards by Kraus USA Inc. ("Kraus"). Kraus extends this warranty to the original purchaser for personal household use of the "Faucet" in its original location. The warranty is non-transferable. Kraus warrants the structure and finish of the product to be free from defects in material and workmanship under normal usage for the lifetime of the product. The warranty commences from the initial date of purchase by the owner or trade professional, from an authorized Kraus dealer, through the lifetime of the original owner or end-user.

Kraus warrants the mechanical components such as but not limited to sprayhead assembly (includes engine, aerators, structure, restrictors, back flow preventers, sprayer hoses, braided supply line hoses which encompasses nylon, silicon and stainless steel, etc) of the product to be free from defects in material and workmanship under normal usage for a period of one (1) year. The warranty commences from the initial date of purchase by the owner or trade professional, from an authorized Kraus dealer, through the one (1) year term of the original owner or end-user.

Kraus warrants the mechanical component (cartridge) of the product to be free from defects in material and workmanship under normal usage for a period of five (5) years. The warranty commences from the initial date of purchase by the owner or trade professional, from an authorized Kraus dealer, through the five (5) year term of the original owner or end-user.

Any product reported to the authorized dealer or to Kraus as being defective within the warranty period will be repaired or replaced with a product of equal value at the option of Kraus. This warranty extends to the original owner or end-user, and is not transferable to a subsequent owner.

Restrictions

This warranty does not cover antediluvian, discontinued, or display products, whether such items are purchased at discount outlets, unauthorized dealers, and/or sold on clearance.

This warranty does not cover instances of negligence, misuse, abuse, improper installation, carelessness, accident, hard water or mineral deposits, exposure to corrosive materials, misapplication, damages caused by improper maintenance, alteration of the product, or failure to follow care or installation instructions enclosed with your product. Avoid using abrasive cleaners such as powders, bleach, ammonia, alcohol, or chlorine. Avoid using abrasive pads, steel wool, or wire brushes, as these will damage and wear down the finish.

This warranty does not apply to Products that have not been installed or operated in accordance with instructions supplied by Kraus and all applicable rules, regulations, and legislation pertaining to such installations.

This warranty does not apply unless the Kraus product is installed by a fully insured and licensed trade professional. Kraus insists that such professionals have experience in the installation of bathroom and kitchen manufactured goods.

This warranty does not cover labor charges or costs of removal and reinstallation of said product. This warranty does not allow recovery of incidental or consequential damages, such as loss of use, delay, property damage, or other consequential damages, and Kraus accepts no liability for such damages.

This warranty does not cover Marine or Outdoor Installation.

Except as otherwise provided above, Kraus makes no warranties, expressed or implied, including warranties of merchantability and fitness for a particular purpose, or compliance with any code.

Shipping charges will be covered for the first (1) year of the warranted replacement part or product (HI, AK, and Puerto Rico shipping charges may apply). International shipping fees are not included.

Commercial Warranty

Kraus extends the above warranty for a period of one (1) year to purchasers of products for industrial, commercial, and business use.

All incidental or consequential damages are specifically excluded. No additional warranties, express or implied, are given, including but not limited to any implied warranty of merchantability or fitness for a particular purpose. Some states do not allow the exclusion or limitation of incidental or consequential damages or limitations on how long an implied warranty lasts, so the above limitations or exclusions may not apply to you. This warranty gives you specific legal rights, and you may also have other rights which vary from state to state.

If you are a homeowner please contact a Kraus Customer Service Representative at:

Kraus USA, Inc.
12 Harbor Park Drive
Port Washington, NY 11050
Toll-free 800-775-0703
Customerservice@kraususa.com

If you are a plumbing contractor or trade professional please contact a Kraus Pro Representative at:

Kraus USA, Inc.
12 Harbor Park Drive
Port Washington, NY 11050
516-801-8955
Proservice@kraususa.com

If you are an Authorized Partner please contact a Partner Support Representative at:

Kraus USA, Inc.
12 Harbor Park Drive
Port Washington, NY 11050
516-801-8954
Partnersupport@kraususa.com

In requesting warranty service, please be ready to provide:

1. Proof of purchase.
2. A description of the problem.

Download the Kraus Care & Maintenance Guide at:

<http://www.kraususa.com/maintenance>

IMPORTANT

Register Your Kraus Product

Activate Your Warranty

Access Premium Customer Support

Get Product Information

REGISTER TODAY

<http://www.kraususa.com/registration>



Kräus[®]
www.kraususa.com