

# Assembly Instructions

BM182973

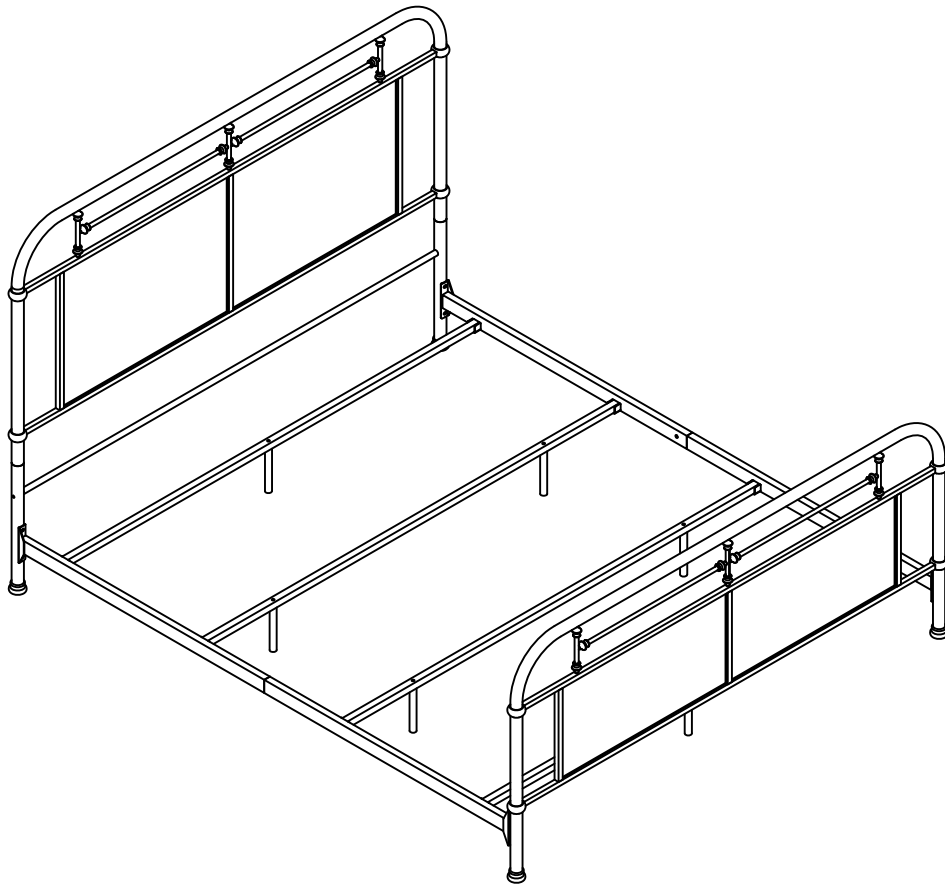

## ASSEMBLY RATING

The Assembly Rating is a 5-point system that shows the degree of effort needed in assembling a specific product (with 1 being easy and 5 being difficult). For some products, two persons are recommended.

EASY  DIFFICULT

Tools Required For Assembly:

Allen Wrench

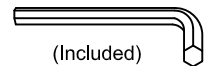

2 PERSONS RECOMMENDED

# ASSEMBLY & CARE ADVICE

FOR YOUR FURNITURE TO LAST, CORRECT ASSEMBLY AND PROPER MAINTENANCE ARE NECESSARY. PLEASE FOLLOW THE INFORMATION PROVIDED BELOW TO FULLY ENJOY YOUR FURNITURE.

## BASIC ASSEMBLY TECHNIQUES

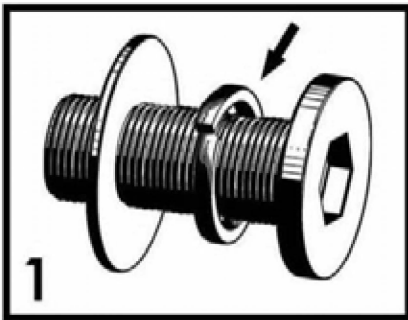

When lock or spring washer is used in an assembly, please make sure the lock or spring washer is placed between the larger flat washer and the head of the screw or bolt.



Position each part correctly and insert screws or bolts into their respective holes by hand tighten or using the proper hand tool. Only tighten when step is completed or when instructed to do so.

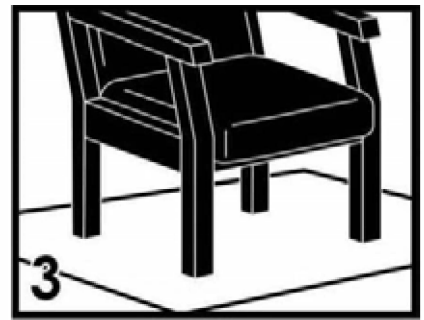

Use cardboard or carpet area when assembling furniture to prevent scratches. Make sure the furniture rests on a flat and level surface with each leg evenly touching the floor.

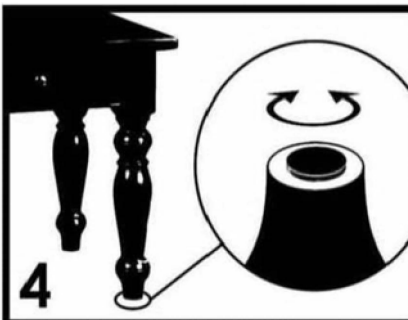

Some furniture comes with height adjustment knobs underneath each leg. To lower or to raise each leg, you need to turn clockwise or counterclockwise, respectively.

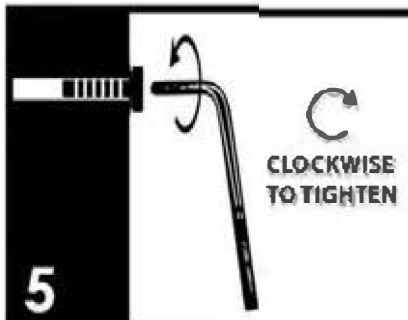

Make sure all parts are properly aligned, then use the appropriate hand tool to completely tighten the bolts or screws. Do not use power tools and do not overtighten.

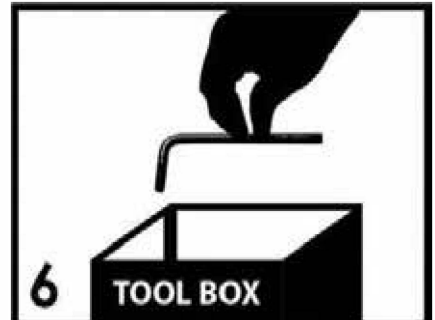

Save the instructions and store the Allen wrench or any supplied tool for later maintenance. After two weeks, check and tighten any loose hardware and repeat again every six months thereafter.

IT IS THE USER'S RESPONSIBILITY TO MAINTAIN THE FURNITURE. THE HARDWARE MAY LOOSEN OVER TIME AND MAY CAUSE THE FURNITURE TO BE WOBBLY AND UNABLE TO SUPPORT ITS INTENDED WEIGHT CAPACITY. THIS MAY LEAD TO COLLAPSE AND MAY CAUSE SERIOUS INJURY.



**FAILURE TO FOLLOW THE GUIDELINES ABOVE MAY RESULT IN INJURY AND/OR PROPERTY DAMAGE.**



Before you begin, please read Page 2 of "Assembly and Care Advice".

And remember, do not tighten until each step is completed or instructed.

### Parts List

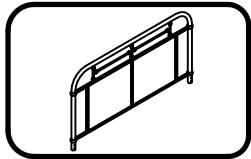
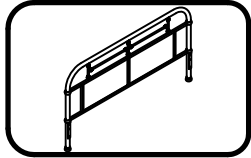
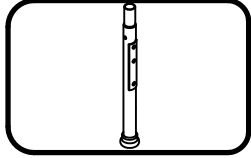
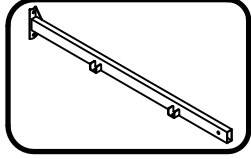
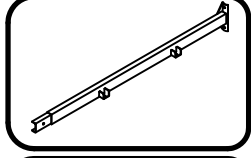
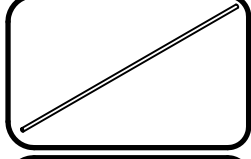
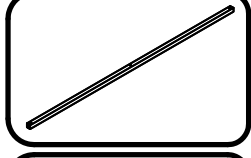
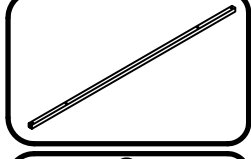
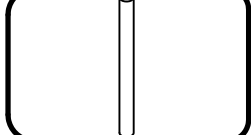
-  #1 x 1pc  
Headboard
-  #2 x 1pc  
Footboard
-  #3 x 2pcs  
Headboard Leg
-  #4 x 2pcs  
Side Rail A
-  #5 x 2pcs  
Side Rail B
-  #6 x 1pc  
Headboard Leg Support
-  #7 x 2pcs  
Slat A
-  #8 x 2pcs  
Slat B
-  #9 x 6pcs  
Support Leg

### Hardware List

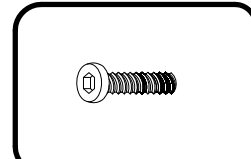
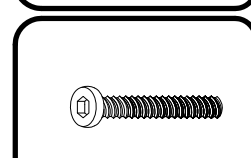
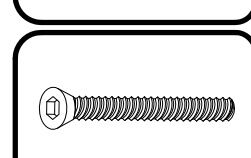
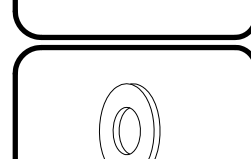
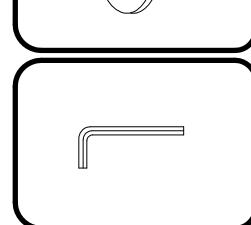
-  #A x 26pcs  
BOLT 1/4"x 5/8"
-  #B x 6pcs  
BOLT 1/4"x1-3/4"
-  #C x 2pcs  
BOLT 1/4"x2-1/4"
-  #D x 32pcs  
Flat Washer
-  #E x 1pc  
Allen Wrench

# Exploded View

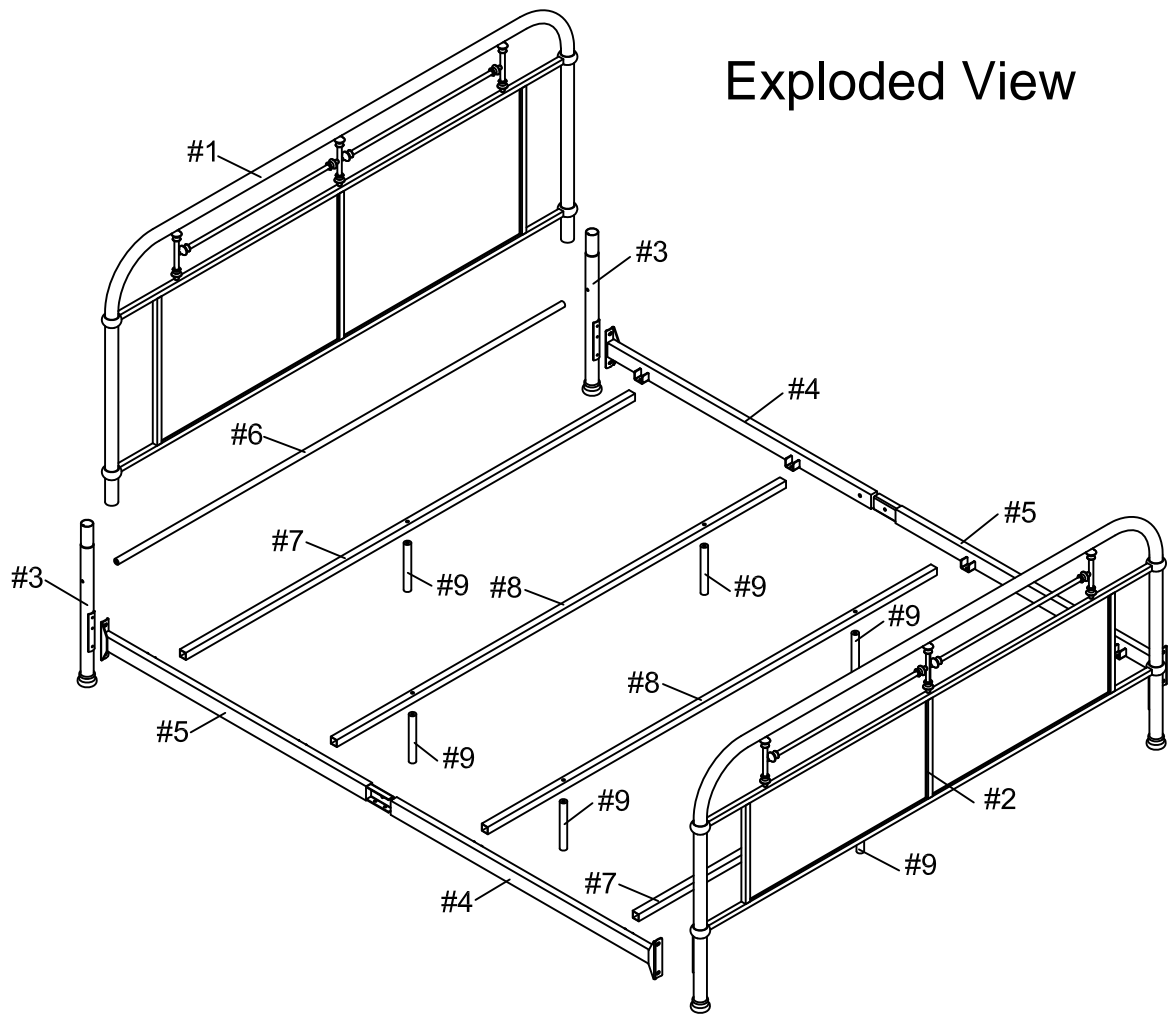

## ASSEMBLY

Do not fully tighten all bolts until assembly is complete. This will help all parts to assemble properly.

#C  2pcs

#E 

Align HB leg support (#6) to the holes of the HB legs (#3).  
Secure by using bolts (#C).

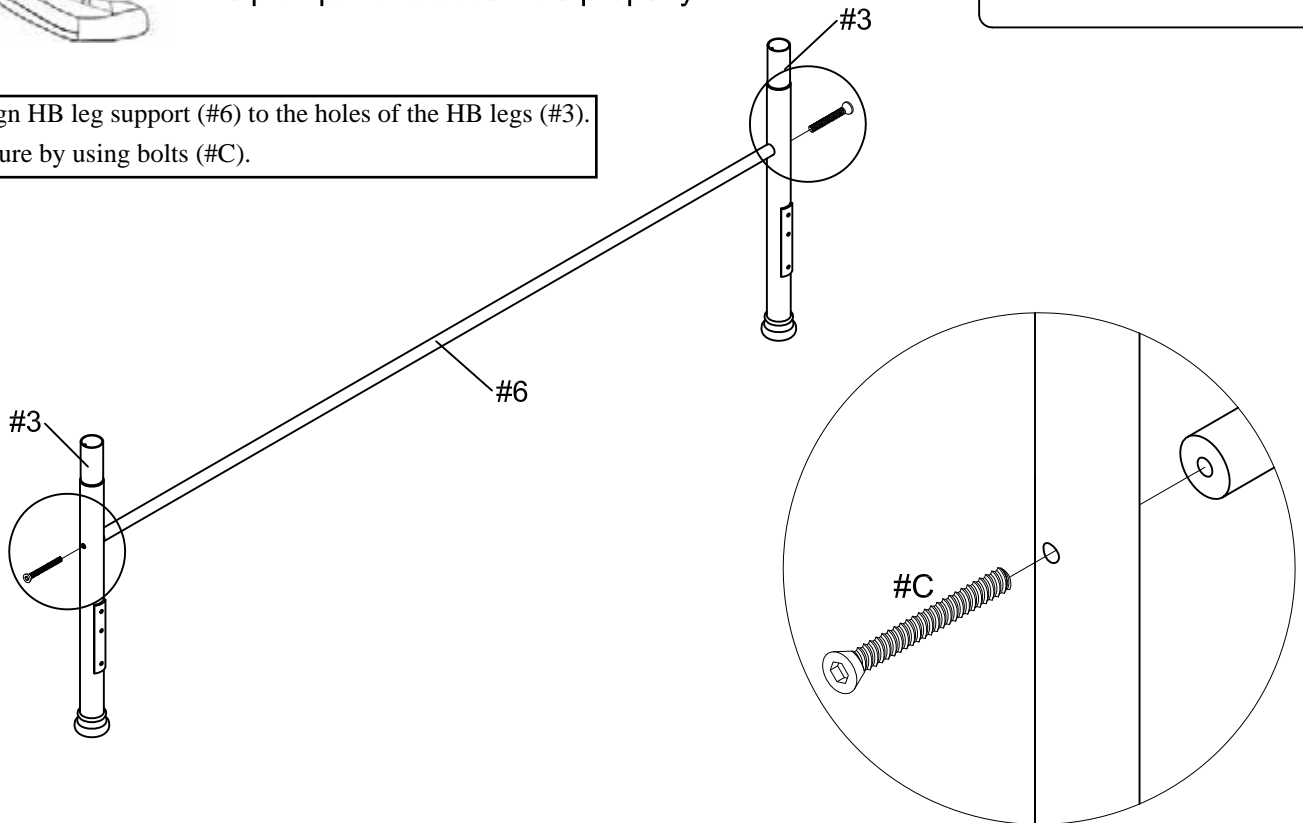



#2

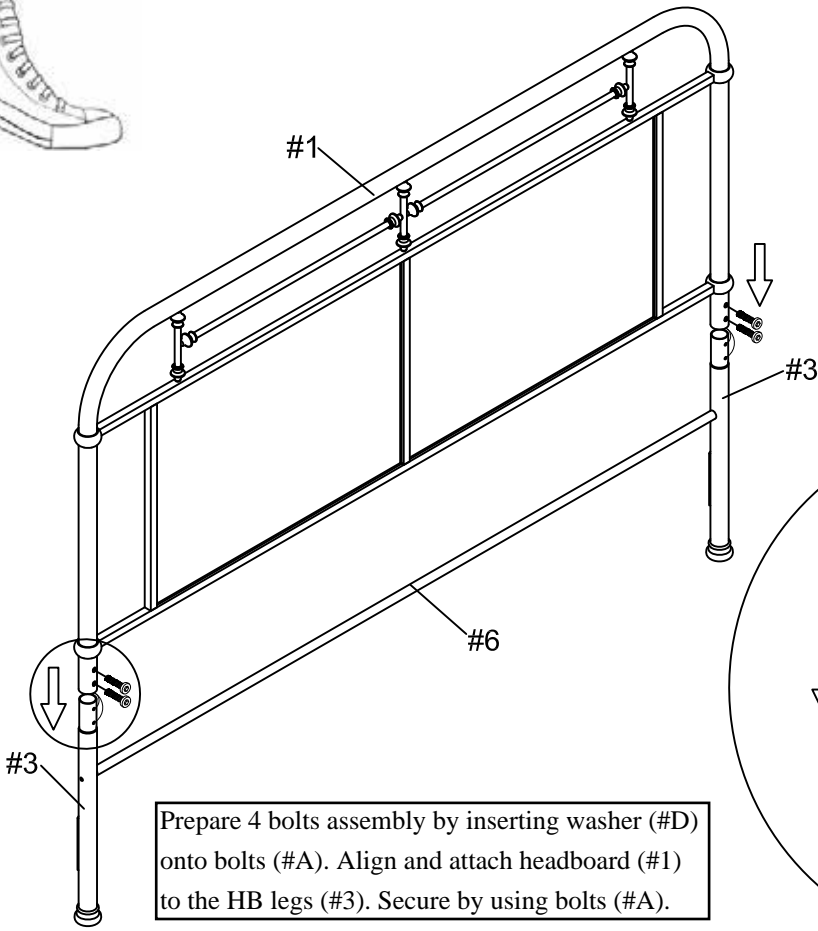

#A		4pcs
#D		4pcs
#E		

Prepare 4 bolts assembly by inserting washer (#D) onto bolts (#A). Align and attach headboard (#1) to the HB legs (#3). Secure by using bolts (#A).

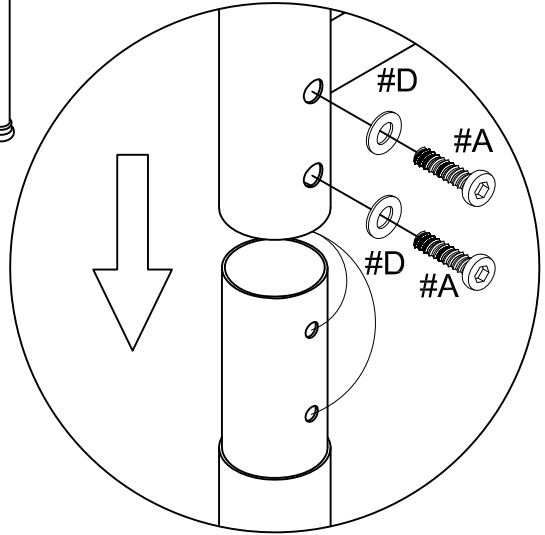



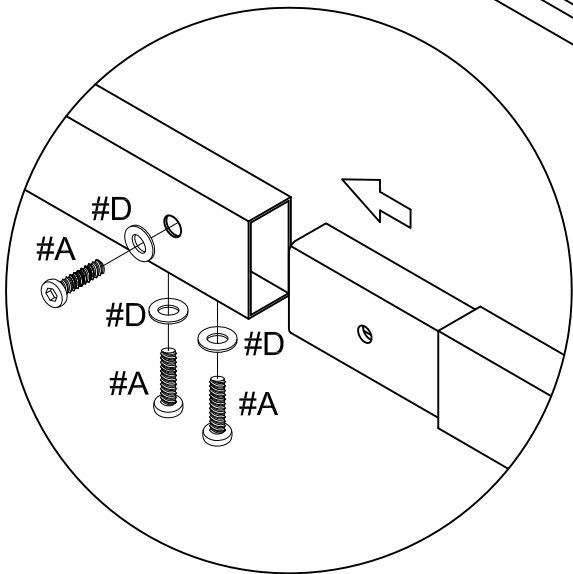
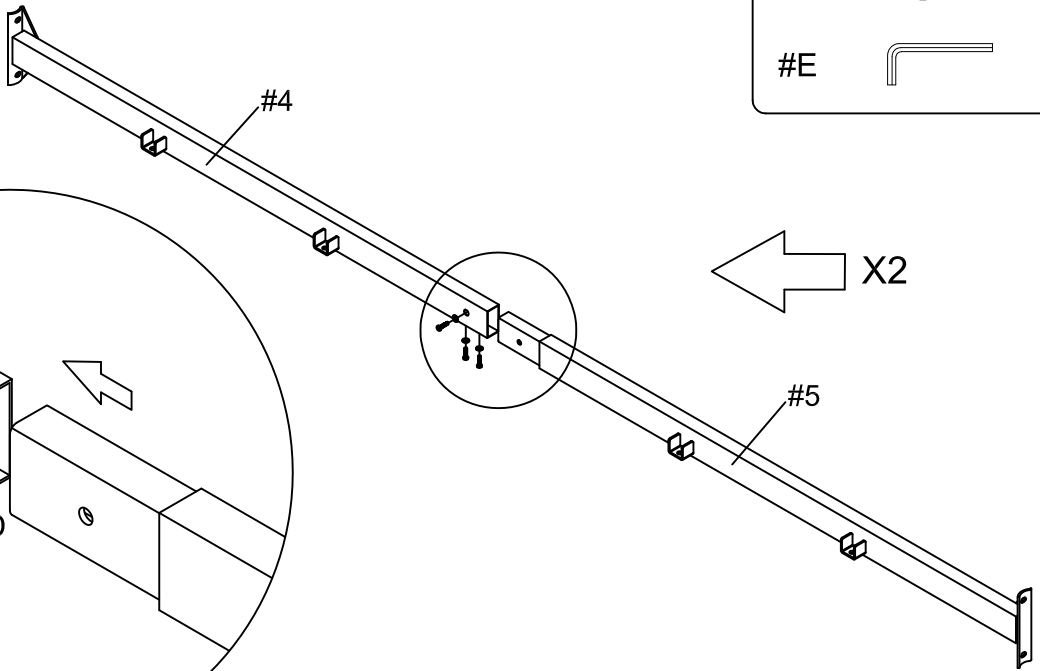

#3

Prepare 6 bolts assembly by inserting washer (#D) onto bolts (#A). Align and attach side rail (#4) onto side rail (#5). Secure by using bolts (#A).

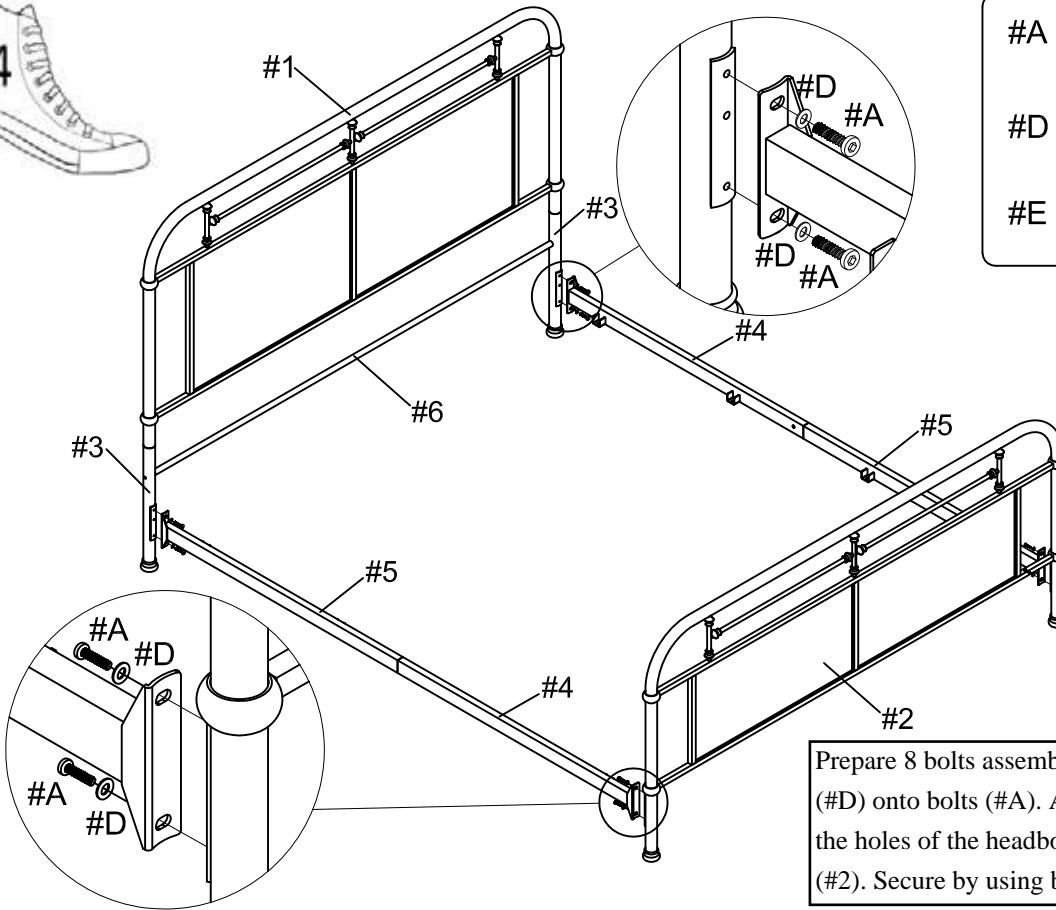
#A		6pcs
#D		6pcs
#E		







- #A  8pcs
- #D  8pcs
- #E 

Prepare 8 bolts assembly by inserting washer (#D) onto bolts (#A). Align side rails (#4,5) to the holes of the headboard (#1) and footboard (#2). Secure by using bolts (#A).



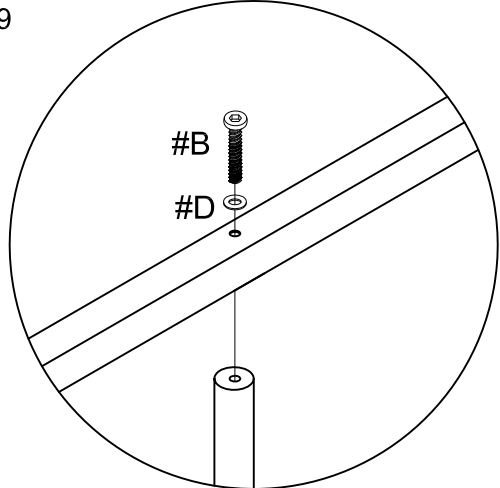
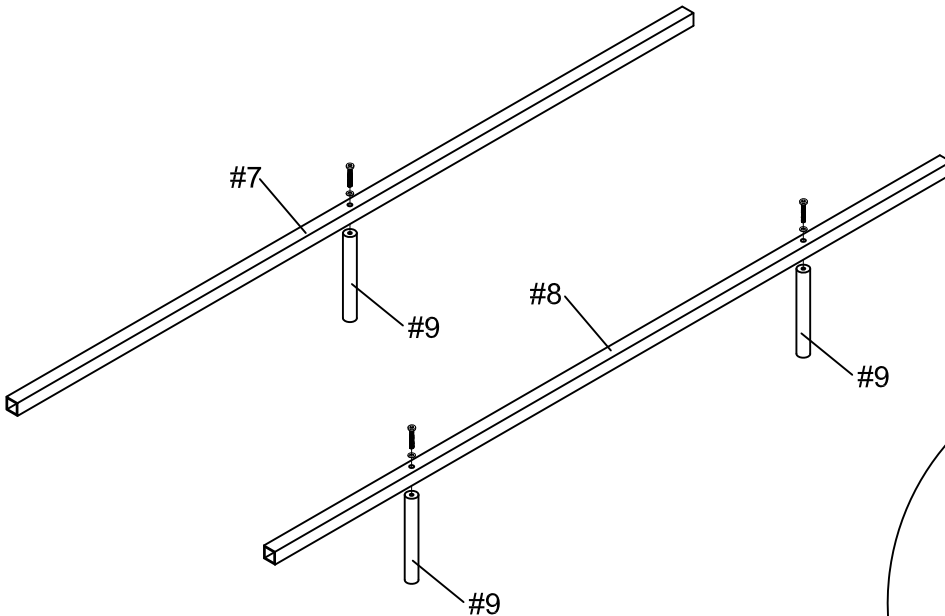

Prepare 6 bolts assembly by inserting washer (#D) onto bolts (#B). Align support legs (#9) to the holes of the slats (#7,8). Secure by using bolts (#B).

- #B  6pcs
- #D  6pcs
- #E 





Prepare 8 bolts assembly by inserting washer (#D) onto bolts (#A).  
Align slats (#7,8) to the side rails (#4,5). Secure by using bolts (#A).

#A		8pcs
#D		8pcs
#E		

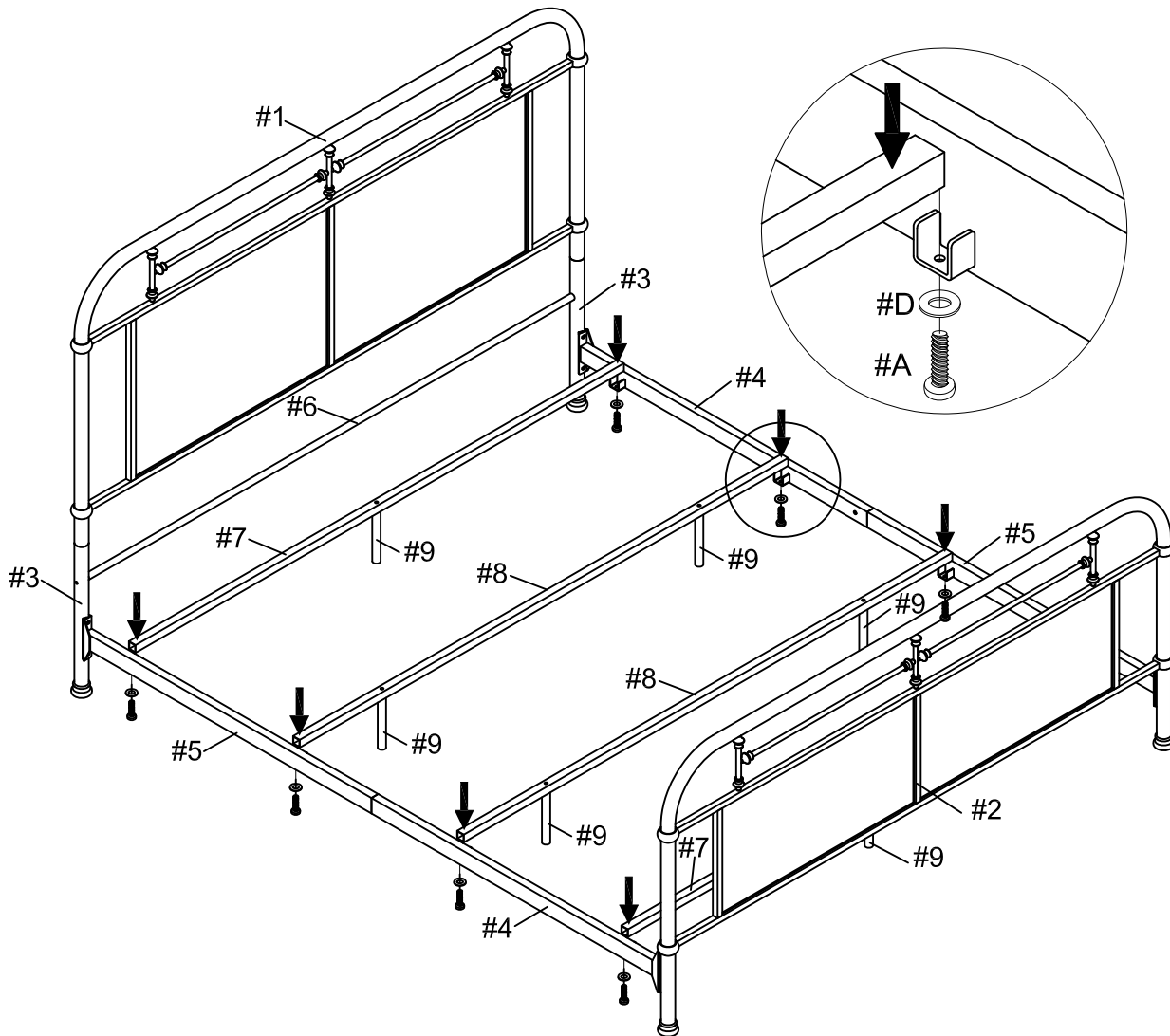

## ▲ WARNINGS:

- Do not remove warning label from bed.
- Use only mattress which is 79"-80" long and 59"-60" wide.
- Do not allow horseplay or under the bed and prohibit jumping on the bed.
- Periodically check and ensure that all the components are in their proper position, free from damage, and that all connectors are tight.
- Do not use substitute parts, Contact the store for replacement part.
- Maximum total weight is not to exceed 600 lbs.
- **Keep these instructions for future reference.**