

## Owner's Manual

### EC110S Portable Evaporative Cooler

---

**IMPORTANT SAFETY INFORMATION:** Please carefully read this manual before attempting to install or use this evaporative cooler. For your safety, comply with all safety instructions and warnings contained in this owner's manual to prevent personal injury or property damage.

To view the full line of Luma Comfort products, please visit [www.lumacomfort.com](http://www.lumacomfort.com).

**Contents**

Introduction ..... 1

Product Benefits ..... 1

Important Safety Information ..... 1

Parts List ..... 2

Operating Instructions ..... 3

*Filling the Water Tank* ..... 3

*Using the Ice Pack* ..... 3

*Using the Remote Control* ..... 4

*The Control & Display Panels* ..... 5

Maintenance ..... 6

*General Maintenance Instructions* ..... 6

*Cleaning the Dust Filter & Cooling Pad* ..... 6

*Cleaning the Water Tank* ..... 7

Troubleshooting ..... 8

Technical Support ..... 8

Product Specifications ..... 8

Warranty ..... 9

## Introduction

Thank you for purchasing this evaporative cooler from Luma Comfort, the world leader in home appliances and home comfort products.

This owner's manual provides specific operating instructions for your evaporative cooler. Use the evaporative cooler only as instructed in this owner's manual.

## Product Benefits

- Designed for cooling small to medium size bedrooms, living rooms, sunrooms, patios and offices
- Sleek, modern design makes it an attractive addition to your home
- High-efficiency, rigid cooling pad holds more water
- Removable water tank makes refilling and emptying easy
- Powerful motor results in more powerful airflow, faster evaporation and cooler air
- Consumes about as much electricity as your typical 100 watt light bulb
- Eco-friendly evaporative cooling system cools the air by the natural process of evaporating water with no Freon or harmful chemicals
- Adds moisture to dry environments and eliminates airborne dust particles
- Covers up to 250 square feet

## Important Safety Information

These instructions are not meant to cover every possible condition and situation that may occur. Please read all instructions before using this evaporative cooler. Failure to carefully read all instructions may result in possible electric shock or fire hazard, and will void the manufacturer's warranty.

1. Use this evaporative cooler only as instructed in this owner's manual. Other uses may cause electric shock, injury or fire.
2. Close supervision is required if this cooler is used near children or pets.
3. To protect against electric shock, do not immerse this cooler or its plug and cord in water.
4. If the cooler is being transported or will not be in use, disconnect it from the power supply by tightly gripping the plug and pulling it from the power outlet. Do not disconnect the power supply by pulling on the evaporative cooler's power cord.
5. Avoid contact with any of the evaporative cooler's moving parts.
6. Place the evaporative cooler on a level surface.
7. This evaporative cooler is intended to fit into a matching receptacle. Under no circumstances should the plug be altered in any way. An improper connection can result in electric shock.
8. If possible, avoid using extension cords with this evaporative cooler. If an extension cord is absolutely necessary, do not use more than one extension cord to operate more than one cooler.
9. Do not insert objects or allow fingers to enter into the cooler's grills, as this may cause electric shock or bodily injury. Do not block or tamper with the evaporative cooler while it is in operation.
10. Do not run the power cord under mats or carpeting, and do not cover the power cord with runners. Arrange the power cord away from room traffic and where it can be tripped over.
11. Do not operate this evaporative cooler in the presence of flammable substances or explosives.
12. Do not place the cooler near an open flame or cooking/heating appliances.
13. If the evaporative cooler will not be in use, empty the tank of any remaining water.
14. If the cooler's plug or power cord is damaged, do not attempt to repair the components yourself. Please contact Luma Comfort's customer service hotline at 1-866-737-6390 or have the unit examined by an authorized service provider.

**SAVE THESE INSTRUCTIONS**

## Parts List

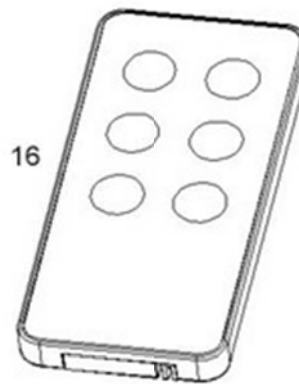
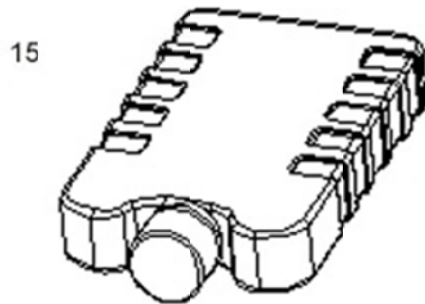
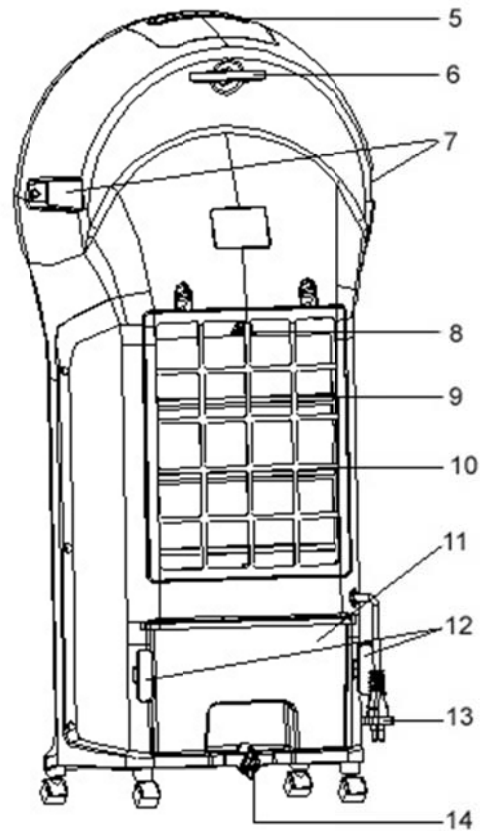
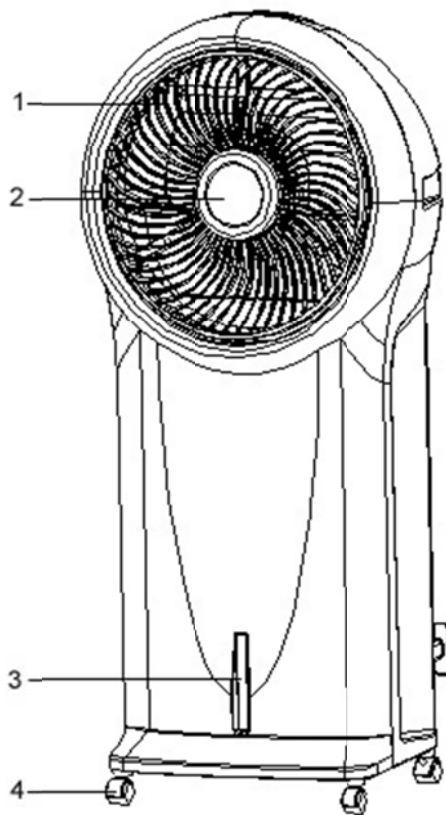

1. Fan head
2. Display panel
3. Water level indicator
4. Caster
5. Control panel
6. Remote control storage slot
7. Carrying handles
8. Cooling pad knob

9. Cooling pad slot
10. Dustproof air filter
11. Water tank
12. Power cord bracket
13. Power cord
14. Water tank knob
15. Ice pack
16. Remote control

## Operating Instructions

Carefully remove all packaging materials and retain for future storage/use. Make sure there is no residual foam left in any of the components. No tools will be required to assemble this evaporative cooler.

### ***Filling the Water Tank***

- a. Remove the water tank by turning the water tank knob counterclockwise 90°.
- b. Before using the evaporative cooler for the first time, we recommend cleaning the tank with a warm water and light detergent solution.
- c. Fill the tank with clean water. Pay attention to the water level indicator located on the front of the cooler to avoid overfilling the evaporative cooler. The approximate tank size of the EC110S is 1.5 gallons (5.5 liters).
- d. Replace the tank back onto the back of the unit. Turn the water tank knob clockwise 90°. This locks the water tank back into place.

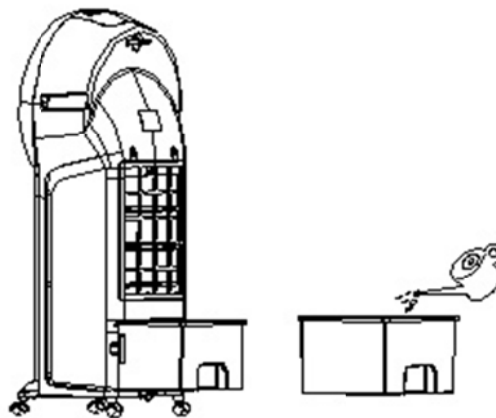

### ***Using the Ice Pack***

- a. The EC110S evaporative cooler includes an optional ice pack for added cooling.
- b. Place the ice pack in the freezer until frozen. Do not open the ice pack or ingest its contents.
- c. Put the ice pack into one of the water tank's chambers.
- d. The ice pack is not necessary for operation, but will help enhance the cooling effect in higher temperatures.
- e. The ice pack will last approximately 4 hours before melting.

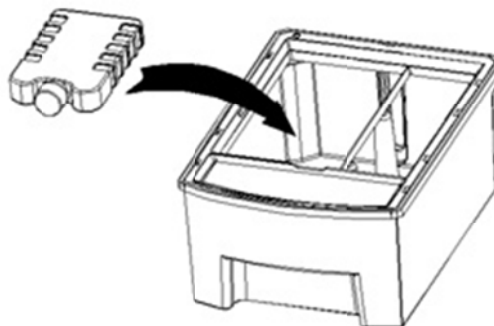

### **Using the Remote Control**

- a. The EC110S is equipped with a remote control. A CR2032 3V coin-type replacement battery is included for your convenience.
- b. To use the remote control, aim it at the unit and select one of the functions on the remote control. The effective distance is approximately 24”.
- c. ON/SPEED = Power ON and adjusts speed
- d. OFF = Power OFF
- e. TIMER = Timer function of up to 7.5 hours
- f. SWING = Swinging air louvers
- g. COOLER/HUMIDIFIER = Controls cooling/humidification function
- h. MODE = Adjusts the airflow mode

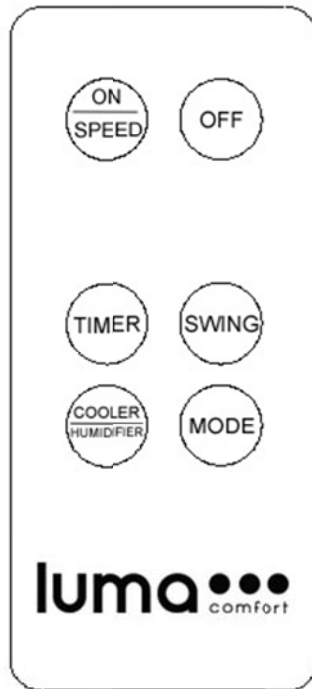

## The Control & Display Panels

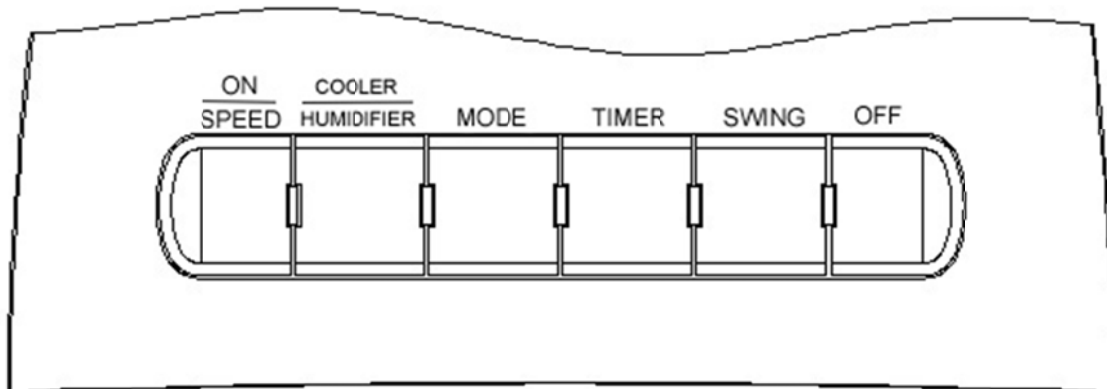

### ON/SPEED & OFF Buttons

- After the tank is filled with water, connect the evaporative cooler to a power outlet. The unit will beep twice, indicating that the power source is connected. The cooler will be in standby mode at this time. Press the **ON/SPEED** button to turn on the evaporative cooler.
- To adjust the fan speed, press the **ON/SPEED** button again until your desired speed has been reached. The current fan speed will be indicated on the display panel. To turn the unit off and revert back to standby mode, press the **OFF** button.

### COOL/HUMIDIFIER Button

- After the desired fan speed has been selected, press the **COOLER/HUMIDIFIER** button to activate the cooling/humidifying function. This powers the water pump and will cool and add moisture to the air at the same time. The blue cooling icon will also be visible on the display panel.
- Please note that if the initial fan speed is set to 3, the unit will revert back to the second speed setting for 5 minutes. After 5 minutes, the unit will automatically switch to the third fan speed. This is to allow the cooling pad to be thoroughly absorbed with water, which results in optimized cooling. The cooler will not revert back to other speeds if the initial fan speed was set to either 1 or 2.

### MODE Button

- The EC110S has 2 different automatic airflow modes. Setting the airflow mode is optional.
- To set the airflow mode, press the **MODE** button.
  - Natural Mode* – Indicated by the palm tree icon on the display panel, this setting will adjust the airflow speed between 1, 2 and 3.
  - Sleep Mode* – Indicated by the moon icon on the display panel, this setting will gradually lower the speed at different intervals, depending on the selected fan speed. If the fan speed is set to 3, the cooler will run for 30 minutes on high speed, 30 minutes on medium speed and then continue to operate on low speed. If the fan speed is set to 2, the cooler will run for 30 minutes on medium speed and then continue to operate on low speed. If the fan speed is set to 1, the cooler will continuously run on low speed.

### **TIMER Button**

- a. This evaporative cooler is equipped with a 7.5 hour programmable timer. To set the timer, press the **TIMER** button. Each press of this button will add 0.5 hours to the set time.
- b. The set time will be indicated in the middle of the display panel.

### **SWING Button**

To activate the oscillation feature, press the **SWING** button. The fan head will automatically oscillate counterclockwise, which directs cool air into a cyclone for a more focused cooling effect.

### **Additional Features**

- a. If the water level in the tank drops below the minimum level, the unit will produce an audible alert that will last for 10 seconds. After 10 seconds, the evaporative cooler will automatically turn off.
- b. If the water tank is removed while the unit is on, it will automatically turn off.

## **Maintenance**

Regular cleaning and maintenance is an essential step in maintaining the longevity of your evaporative cooler and ensuring that it operates free of defects. Maintain your evaporative cooler by following these steps:

### ***General Maintenance Instructions***

- Always unplug the evaporative cooler from the power supply before servicing or cleaning.
- Use a soft cloth and a mild soap and warm water solution to clean the unit's exterior. Do not use harsh cleaners, gasoline, paint thinner, benzene, etc., as these substances can damage the evaporative cooler.
- Thoroughly dry all of the cooler's parts with a soft cloth before reconnecting the unit to the power supply.
- Empty the water tank after the evaporative cooler has been in use. Regular, scheduled cleaning of the water tank before each use is also recommended.
- If the evaporative cooler will not be in use for an extended period of time, place the unit back in its original carton and keep it stored in a clean, dry place.
- The evaporative cooler's filter, tank and cooling pad will need to be removed prior to cleaning. Once all of the different components have been cleaned, place them back into the unit in this order: water tank, cooling pad and dust filter.

### ***Cleaning the Dust Filter & Cooling Pad***

- To prevent clogging of the dust filter, we recommend cleaning the filter at least once a month.
- To clean the dust filter, remove it from the back of the unit by pushing down on the two tabs located above the filter and pull it out. Gently scrub it with a soft brush and rinse with water. Allow it to thoroughly air dry before placing it back in the unit.
- To clean the cooling pad, first remove the dust filter to expose the pad. Turn the knob on the pad clockwise and pull it out from the back of the unit. Rinse it with clean water and allow it to thoroughly air dry before placing it back in the unit.



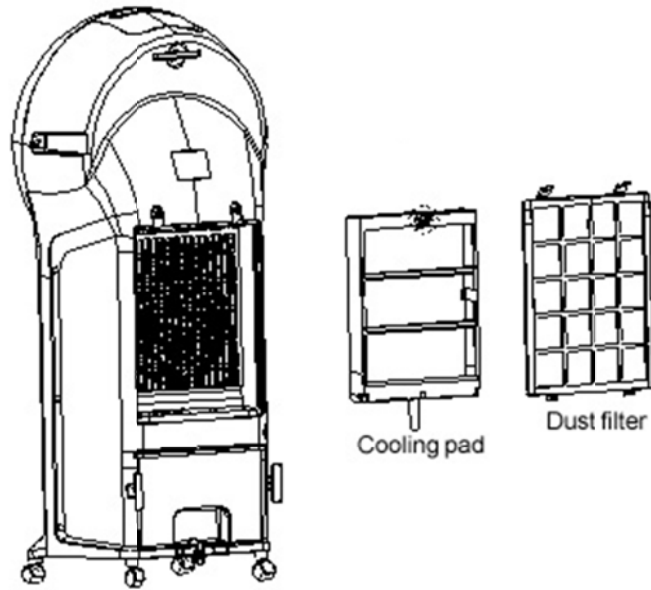

### ***Cleaning the Water Tank***

- Unplug the evaporative cooler from the power supply and empty the water tank after the evaporative cooler has been in use. Regular, scheduled cleaning of the water tank before each use is also recommended.
- To clean the water tank, rinse it in a warm water and light detergent solution. Rinse it with clean water and dry it thoroughly before placing it back into the cooler.

## Troubleshooting

Problem	Possible Cause(s)	Possible Solution
There is no airflow.	The power cord is not plugged in.  The water tank is not locked into the unit.	Check to make sure the plug is plugged into an outlet. The unit should beep twice once the power supply is connected.  Make sure the water tank is locked into the back of the unit.
The unit does not cool.	There is insufficient water in the tank.  The cooler/humidifier button was not pressed.  The pump is defective.	Check the water level in the tank and make sure there is enough water.  Press the COOLER/HUMIDIFIER button.  Contact customer service if there is an issue with the water pump.
The unit does not cool on high speed.	The cooling pad is not sufficiently saturated with water.	If speed 3 is selected when in cooling mode, the unit will automatically revert to speed 2 for 5 minutes to allow the pad to be fully soaked. The cooler will automatically turn to speed 3 when the pad is soaked.
Water is coming out of the vents.	The cooling pad may be clogged with debris.	Clean the cooling pad by rinsing it in water and allowing it to thoroughly dry. If the problem persists, contact customer service.

## Technical Support

Luma Comfort is committed to providing a premier service experience. If you are experiencing any technical issues with your product related to either setup or operation, please contact our product support team at 1-866-737-6390 or [support@lumacomfort.com](mailto:support@lumacomfort.com).

## Product Specifications

<b>Model:</b>	EC110S
<b>Product Dimensions:</b>	12.75" x 11.25" x 34.5"
<b>Product Weight:</b>	16.2 pounds
<b>Voltage:</b>	110V-120V
<b>Wattage:</b>	110W
<b>Coverage Area:</b>	Up to 250 square feet
<b>Tank Size:</b>	1.76 gallons
<b>Fan Speeds:</b>	3
<b>Noise Level (dB):</b>	66
<b>Airflow:</b>	500 CFM
<b>Oscillation:</b>	Yes
<b>Warranty:</b>	1 year manufacturer's warranty

## Warranty

Luma Comfort products are warranted to be free from defects in workmanship or materials for one (1) year from the date of purchase. If the product is found to be defective within this period, Luma Comfort, at its sole option, will repair or replace any components that fail during normal operation. The repairs or replacement will be made at no charge to the customer for parts and labor, assuming that the customer shall be responsible for all transportation costs to and from Luma Comfort.

Luma Comfort retains the right to repair or replace (with a new or newly-refurbished replacement product) the appliance at its sole discretion.

This warranty does NOT apply to the following:

- Products without a proof of purchase
- Products purchased from a source other than an authorized Luma Comfort dealer
- Cosmetic damage such as scratches or dents
- Damage caused by service performed by anyone who is not an authorized service provider of Luma Comfort
- Damage in transit
- Damage caused by accident, abuse, misuse, water, flood, fire, improper installation, maintenance negligence, commercial use for a non-commercial unit, acts of God or any other acts of nature or external causes
- Damage to a product caused by modifications or alterations without the written permission of Luma Comfort
- Normal wear and tear of parts that are designed to be replaced, such as filters or batteries
- Power failure and improper power supply such as low voltage, defective wiring or inadequate fuses
- Use of force or damage caused by external influences
- Complete or partially dismantled appliances

THE WARRANTIES AND REMEDIES CONTAINED HEREIN ARE EXCLUSIVE AND IN LIEU OF ALL OTHER WARRANTIES EXPRESS, IMPLIED, OR STATUTORY, INCLUDING ANY LIABILITY ARISING UNDER ANY WARRANTY OF MERCHANTABILITY OR FITNESS FOR A PARTICULAR PURPOSE, STATUTORY OR OTHERWISE. THIS WARRANTY GIVES YOU SPECIFIC LEGAL RIGHTS, WHICH MAY VARY FROM STATE TO STATE.

IN NO EVENT SHALL LUMA COMFORT BE LIABLE FOR ANY INCIDENTAL, SPECIAL, INDIRECT, OR CONSEQUENTIAL DAMAGES, WHETHER RESULTING FROM THE USE, MISUSE, OR INABILITY TO USE THIS PRODUCT OR FROM DEFECTS IN THE PRODUCT. SOME STATES DO NOT ALLOW THE EXCLUSION OF INCIDENTAL OR CONSEQUENTIAL DAMAGES, SO THE ABOVE LIMITATIONS MAY NOT APPLY TO YOU.

If you believe your product is defective, contact Luma Comfort for warranty service at 1-866-737-6390 or [support@lumacomfort.com](mailto:support@lumacomfort.com). In your correspondence with Luma Comfort, please describe the problem and request a return material authorization (RMA) number. You will also need to provide the proof of purchase, return shipping address and a daytime phone number.

After a Luma Comfort representative confirms that your product is defective and is still under warranty, you will receive an RMA and return shipping instructions. Products sent to our headquarters without an RMA will be refused.