

INSTRUCTION MANUAL

Safety Warnings

These products are only suitable for connection to a 240V~50Hz supply in accordance with current IEE wiring Regulations and should be installed in accordance with local Building Regulations and are for Domestic ceiling use only. They are not suitable for a Bathroom location.

The light fitting should be connected to a lighting circuit protected by a 5 amp fuse (or a 6 amp miniature circuit breaker).

If in doubt we recommend you contact a qualified electrician. Before installing your light fitting always:

Switch off the mains supply and remove the appropriate fuse or switch off the appropriate circuit breaker before commencing installation.

Ensure that no one else has access that would enable the supply to be inadvertently reconnected.

Never fit bulbs of a higher wattage or of a type other than those specified on the label as this may cause overheating and damage the fitting.

These products contains glass parts – be careful during handling and maintenance to avoid breakage.

The bulbs become hot during use so please switch off and allow 10 minutes to cool before replacing bulbs or cleaning the fitting.

Clean with a dry cloth only. Do not use liquid or abrasive cleaners on this product.

If any modification is made it will invalidate the warranty and may render the product unsafe.

Before you start

Please read these instructions carefully before fitting your new light and retain for reference.

Make sure that there are no pipes or cables beneath the mounting surface.

Check the packaging and make sure that you have all the required parts.

Follow each assembly step in order to prevent incorrect assembly.

Make sure all screws / nuts, including electrical connections etc are fully tightened before use.

This type of Light Fitting may be connected to a Dimmer if a Tungsten incandescent bulb is used. If a CFL type bulb is fitted then these cannot (generally) be controlled by a dimmer.

The Light pack contains:

Light fitting and mounting bracket.
Terminal connection block(s).

The following tools may be required:

Selection of cross and flat head screwdrivers.
Electric drill and assorted drill bits.
Wire strippers.
Electrical insulation tape.

These assembly diagrams are intended as a guide – if in doubt consult a qualified electrician.
The 5 light fitting is shown here but the same general instruction applies to the 8 light version.

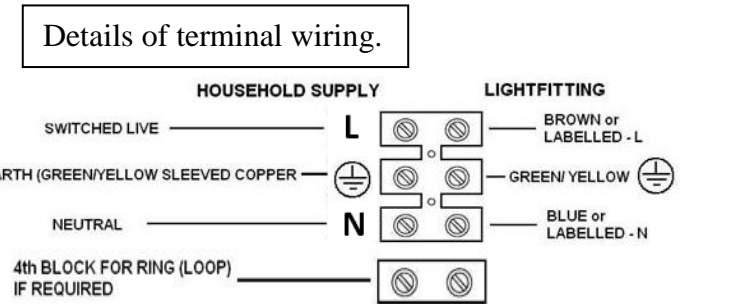
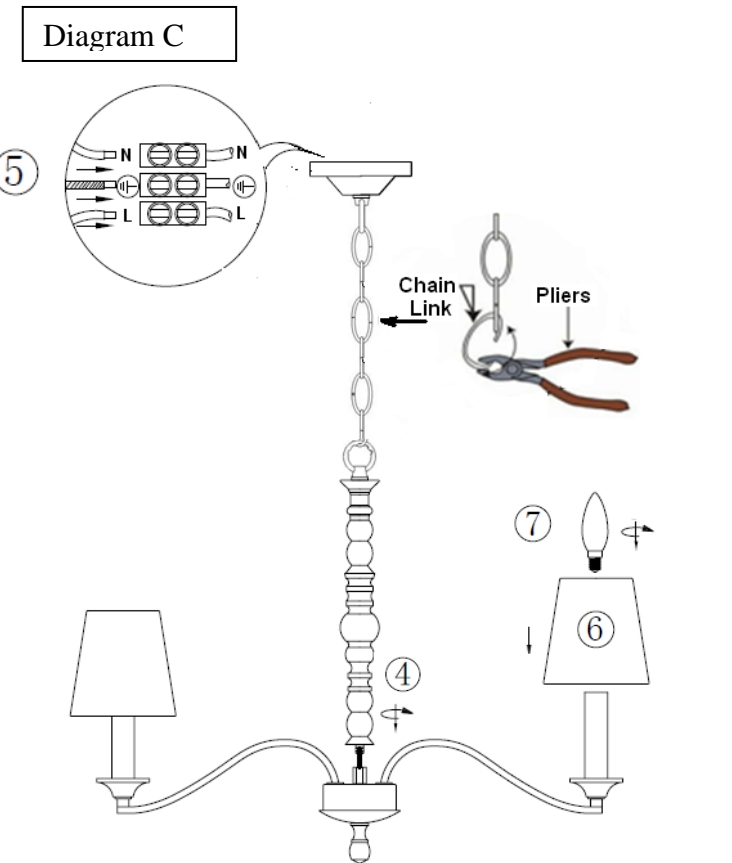
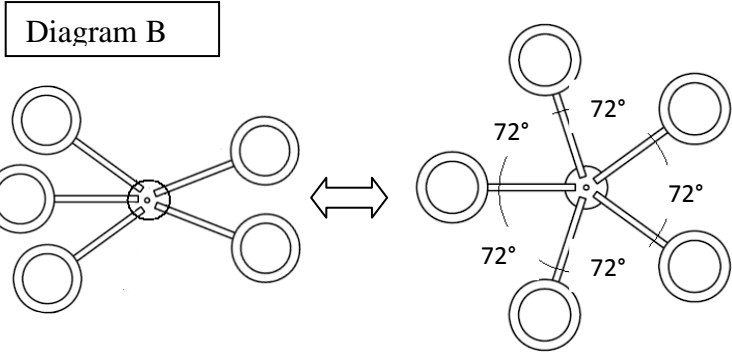
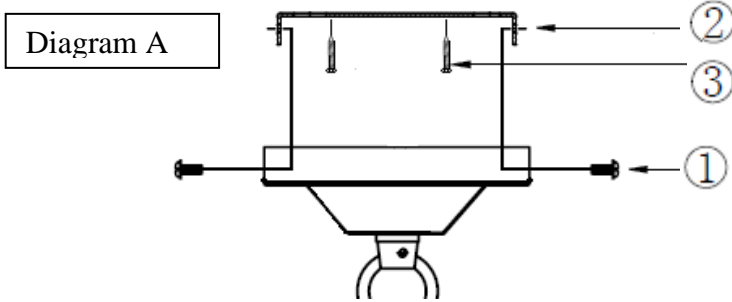

1. Decide on the position of the light fitting / or remove existing light fitting. Take a note of the position of the electrical connections. Ensure there is a solid mounting surface, preferably a wooden joist or joist bridge to support the weight of the light fitting.
2. See **Diagram A**. Remove the fixing bracket, by undoing the 2 side screws (1), retain these for re-use.
3. Use the fixing bracket (2) as a template to mark the screw holes, mark the screw holes and secure to the ceiling with the screws (3) supplied.
4. See **Diagram B**. Your fitting will come 'flat packed'. Before connection to the supply, locate the fixed arm assembly and then pull the other arms into position as shown. **Arm angle approximately 72° for the 5 arm lights and approximately 45° for the 8 arm lights.**
5. See **Diagram C**. If you want to reduce the overall length of the fitting it is essential that this is done before the fitting is mounted to the ceiling and / or connected to the mains supply. Remove the chain links as shown until the desired length is reached. The cable must now be shortened and the excess cable cut and re-connected to the terminal block. Feed the cable up through the plastic bush and form a loop above the ceiling cup. Move the figure of 8 cable anchor down the cable –This is a strain relief device and must be used. Cut off the excess cable and re-connect to the terminal block. **NOTE: The electric cable must always be longer than the chain to prevent strain being placed on the cable.**
6. Secure the body (4) to the arm assembly.
7. Support your fitting and connect the house wiring to the terminal block (5). Cut and strip the cable and connect it to the terminal block as shown – see wiring details. **NOTE: This is a Class I fitting and must be earthed.** The 4th terminal block connector is used for the "loop" wires of the "Ring Circuit". There may be more than one set of cables in the "loop" connections. If there is a "Ring Circuit" and you do not understand the connections you must consult an electrician. Any loose terminal blocks –not secured to ceiling cup - should always be covered with 2 layers of good quality insulation tape.
8. Secure the fitting back onto the fixing bracket with the 2 side screws (1), removed in 2 above. Make sure that all the internal cables and connections are inside the ceiling cup taking care not to trap or strain the internal cables.
9. Fit the shades (6) over the lamp holders and secure by screwing the bulbs (7) into the lamp holders. **NOTE: Never fit bulbs of a higher wattage than those specified on the label (as these may cause overheating and damage the fitting).**
10. Turn on the power and test.