

Montageanleitung

Notice de montage

Assembly instruction

Schuhschrank

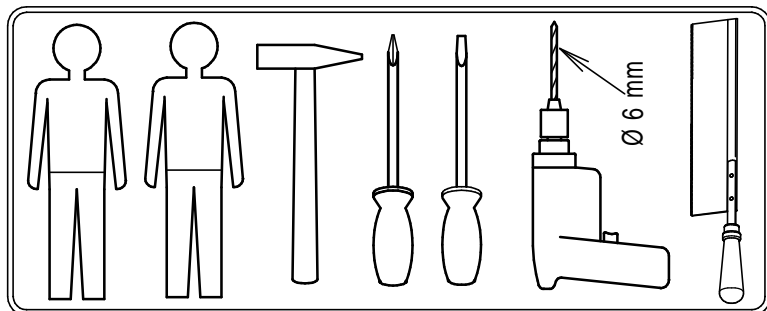
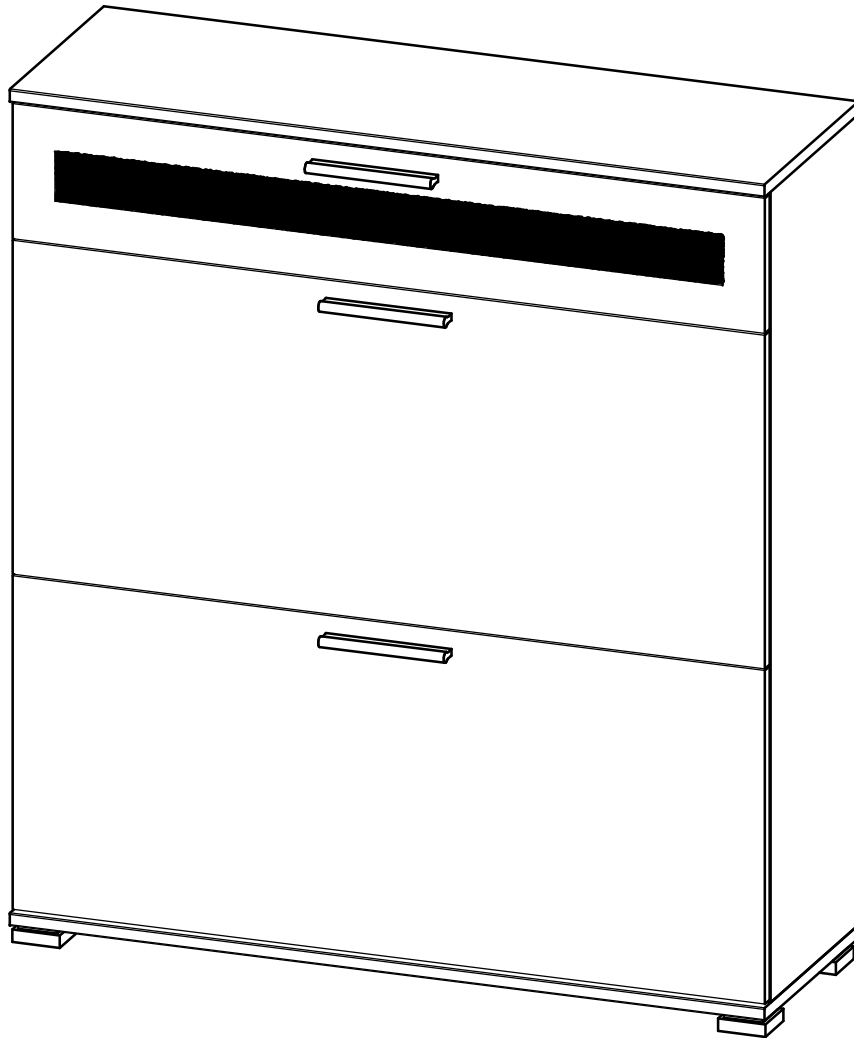











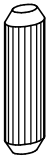

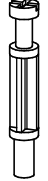

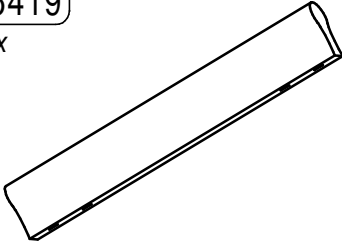
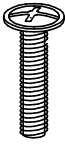
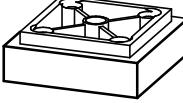
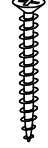
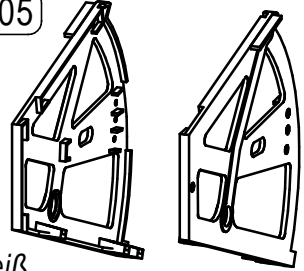
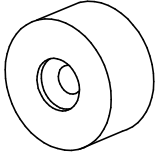
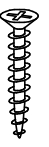

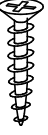
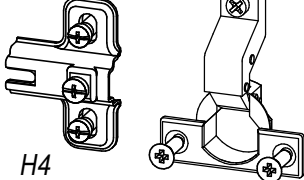
Bitte die Sicherheitshinweise auf der letzten Seite beachten!

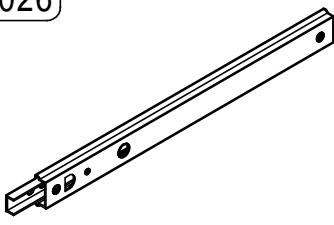
Please note: safety instructions on the last page!

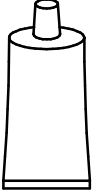
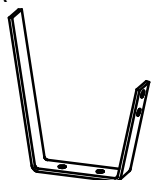
Prière de suivre les instructions de sécurité figurant sur la dernière page!

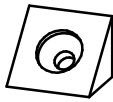
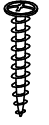
erstellt		geändert		geprüft	
Datum:		Datum:		Datum:	

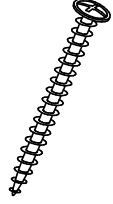
Teileliste - liste de pièces - partlist

<p>2218 12x</p>  <p>Ø8 x 30mm</p>	<p>1116 12x</p>  <p>Ø4 5mm</p>	<p>1114 12x</p> 	<p>1162 4x</p> 	<p>5419 3x</p>  <p>Teilung = 96 mm / 128 mm</p>
<p>1133 6x</p>  <p>M4x21mm</p>	<p>5403 4x</p>  <p>55x55 mm</p>	<p>1071 8x</p>  <p>Ø4x30mm</p>	<p>4305 2 x</p>  <p>weiß</p>	<p>4192 4 x</p>  <p>Ø 20 mm</p>
<p>1069 4x</p>  <p>Ø4x22</p>	<p>1238 12x</p>  <p>Ø6,3x13</p>	<p>1058 20x</p>  <p>Ø3x15mm</p>	<p>4840 4x</p>  <p>H4</p>	<p>1236 4x</p>  <p>Ø6,3x11</p>
<p>4026 2x</p>  <p>214 mm</p>	<p>1235 2x</p>  <p>M4x8</p>	<p>4271 1x</p> 	<p>1244 2x</p>  <p>95 x 55 x 60 mm</p>	<p>1037 8x</p>  <p>Ø3,0 x 10</p>
<p>4095 8x</p>  <p>10x10x13mm</p>	<p>1267 6x</p>  <p>Ø3x16</p>	<p>1187 1x</p>  <p>90x30x15</p>	<p>1110 1x</p>  <p>Ø6x30mm</p>	<p>1021 1x</p>  <p>Ø4,5x40mm</p>
<p>1298 2x</p>  <p>Ø4x15mm</p>				

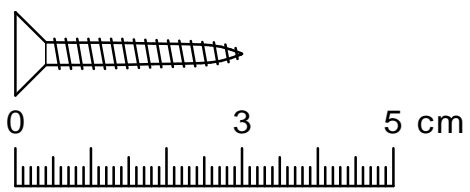

Teileliste - liste de pièces - partlist

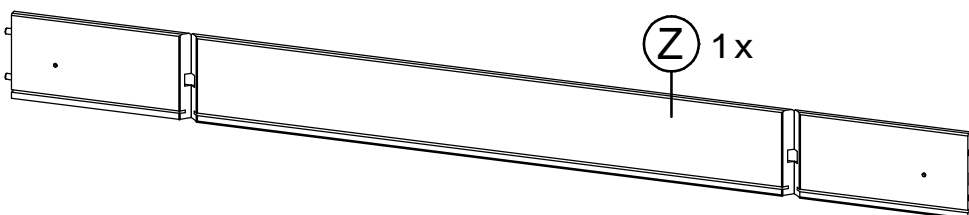
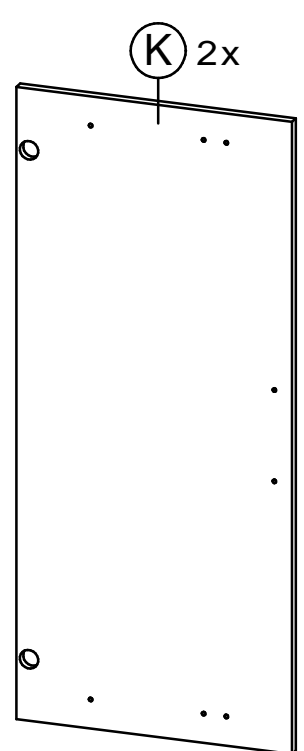
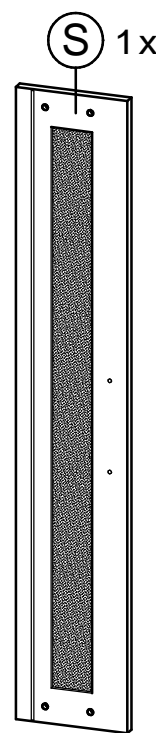
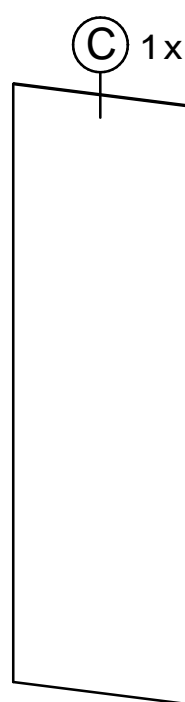
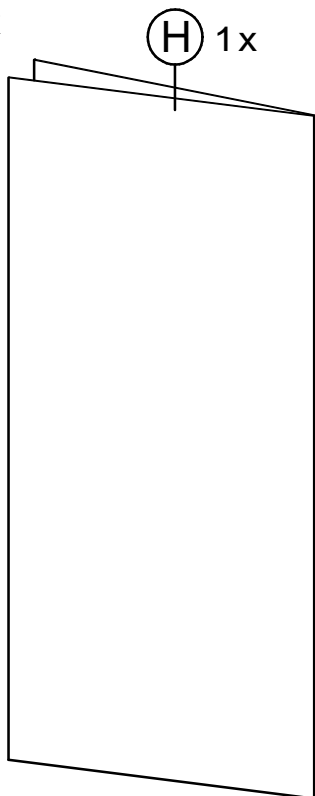
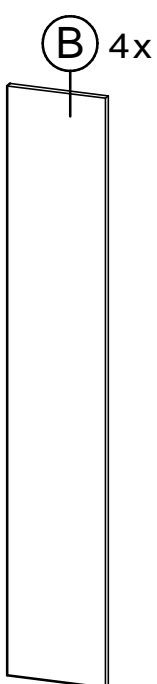
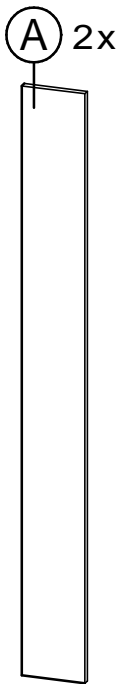
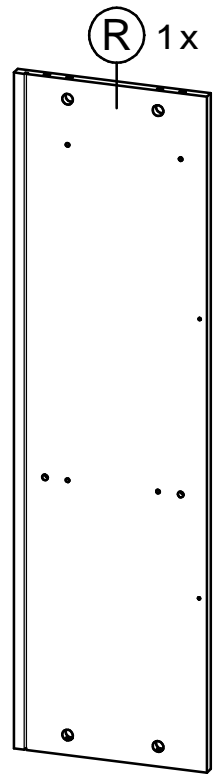
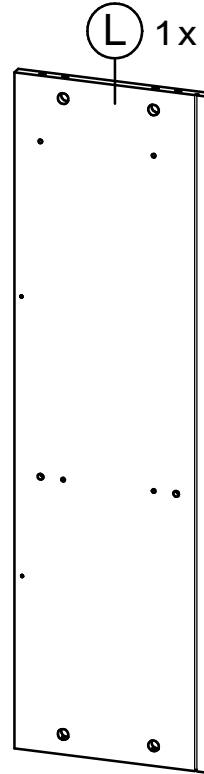
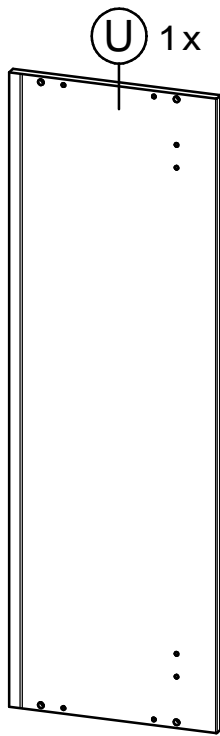
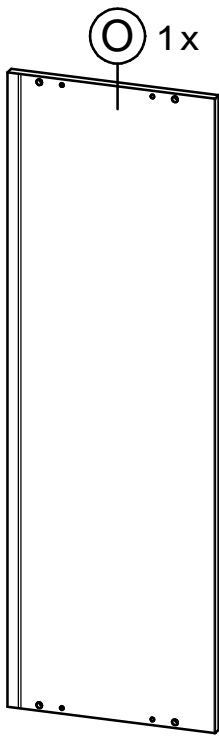

erstellt		geändert		geprüft	
Datum:		Datum:		Datum:	

Montageschritte - ordre de montage - assembly instructions

1.

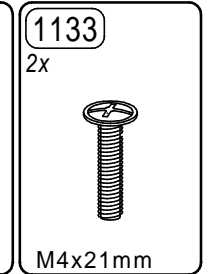
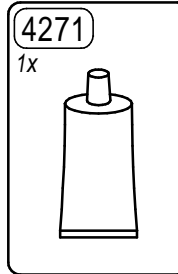
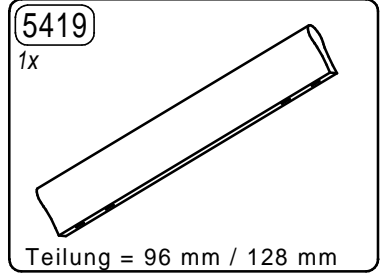
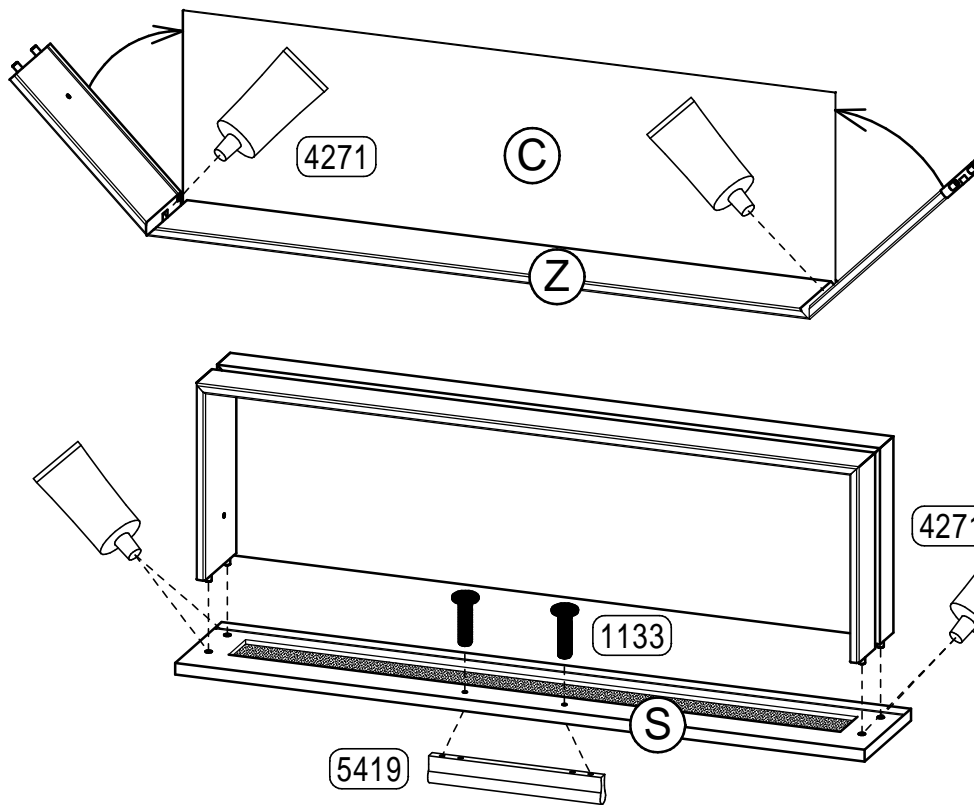

30 min.



2.

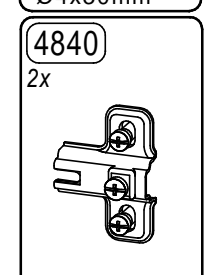
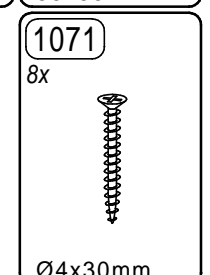
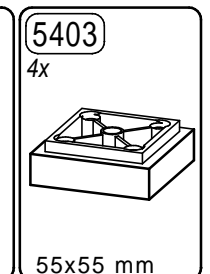
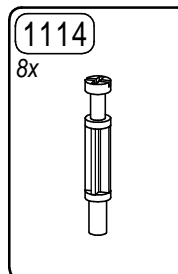
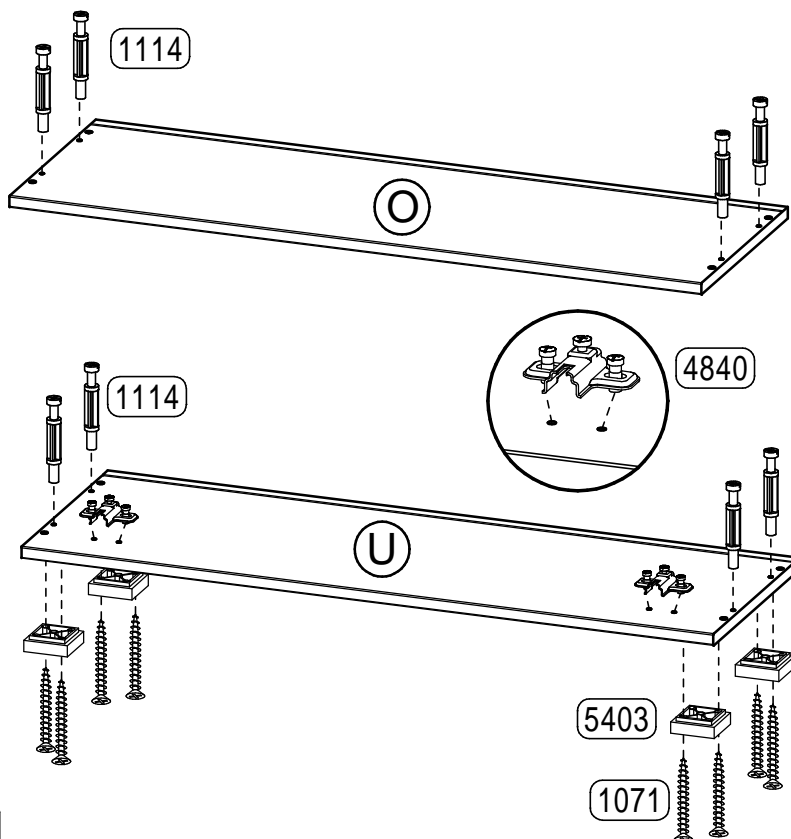

4

erstellt	geändert	geprüft
Datum:	Datum:	Datum:

Montageschritte - ordre de montage - assembly instructions

3.

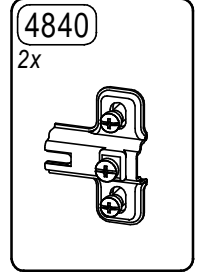
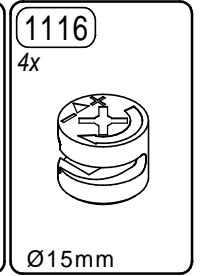
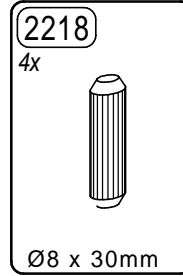
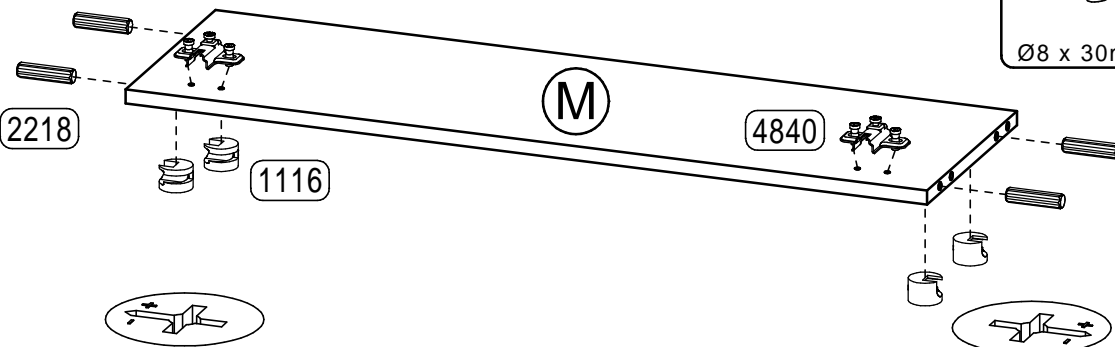

4.

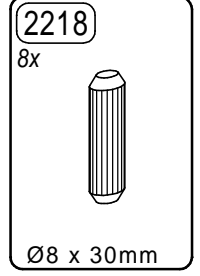
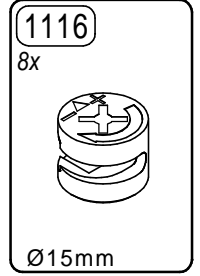
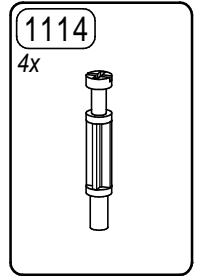
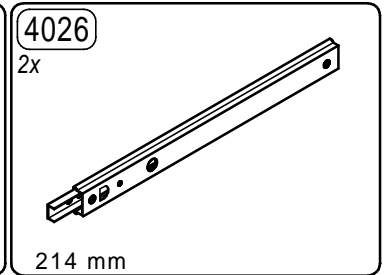
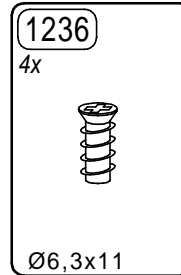
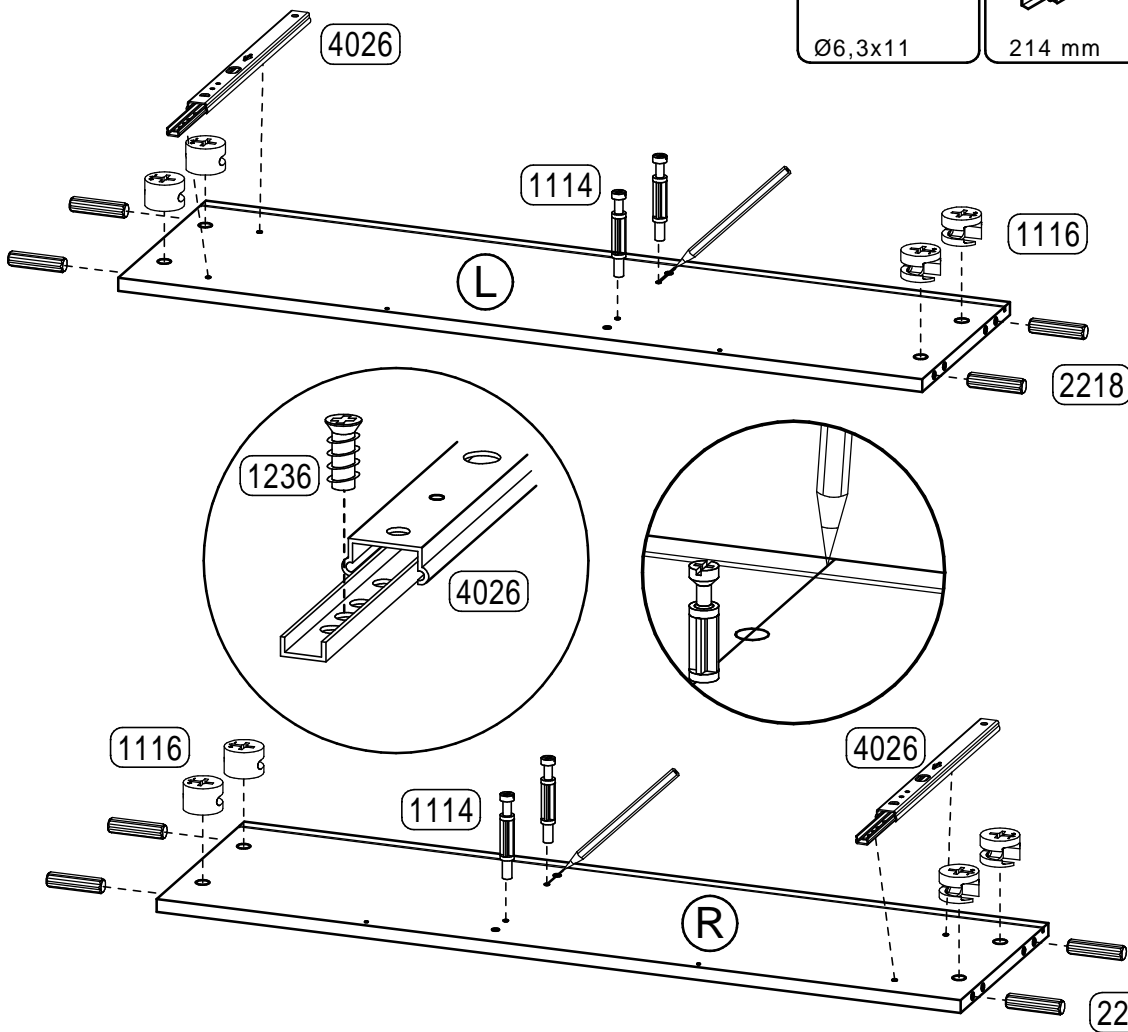

5

erstellt	geändert	geprüft
Datum:	Datum:	Datum:

Montageschritte - ordre de montage - assembly instructions

5.

5.1

2x

5419

2x

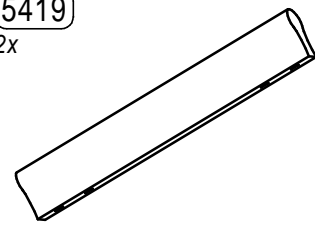

Teilung = 96 mm / 128 mm

4840

4x

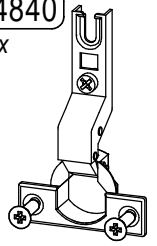

1133

4x

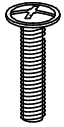

M4x21mm

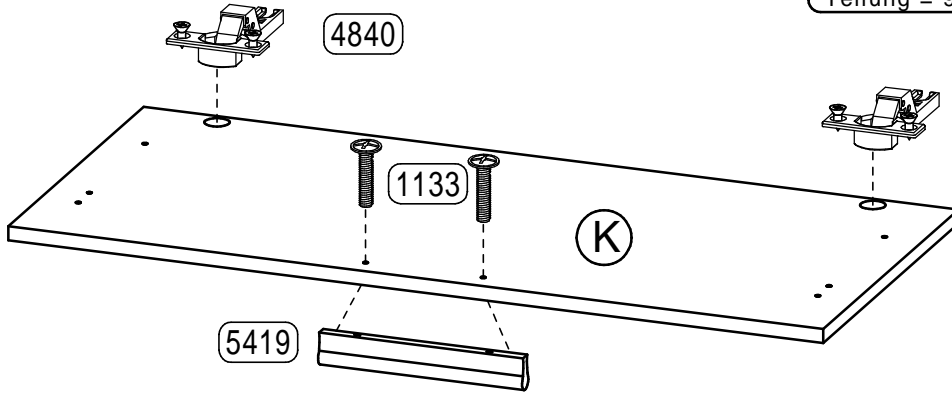

5.2

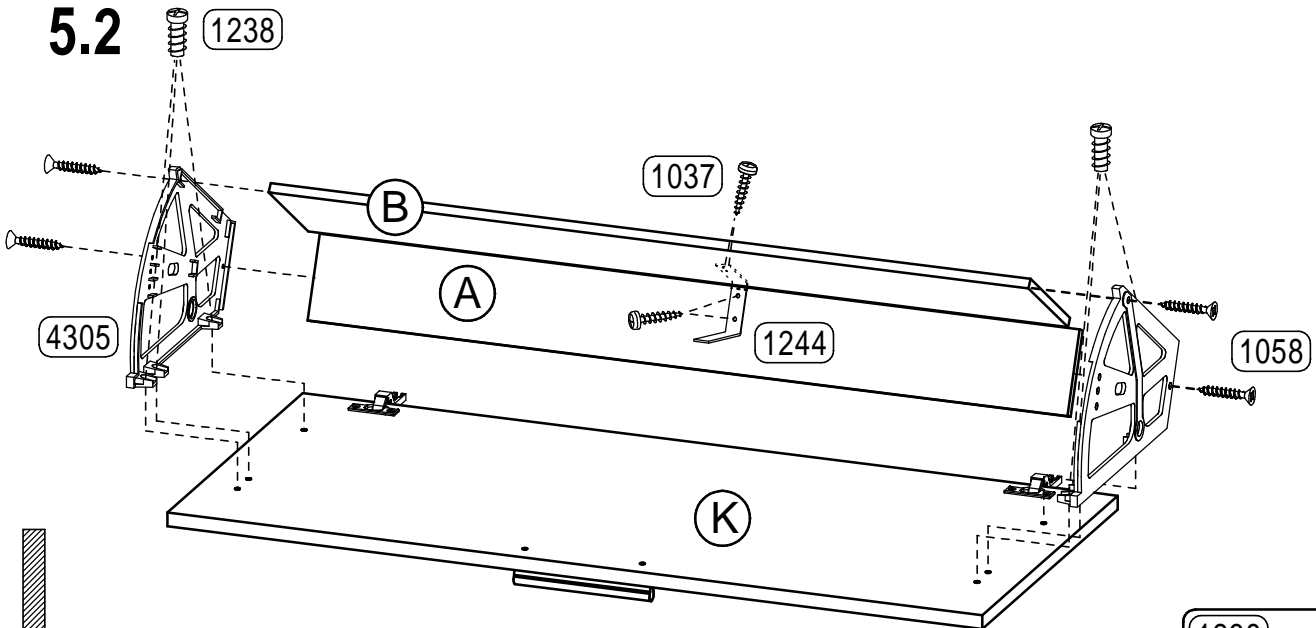

1238

12x



Ø6,3x13

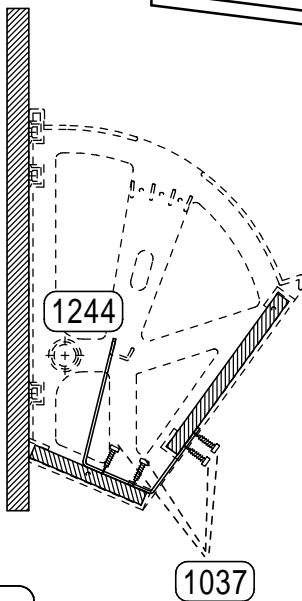

1058

8x

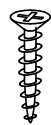

Ø3x15mm

1037

8x



Ø3,0 x 10

1244

2x



95 x 55 x 60 mm

4305

2x

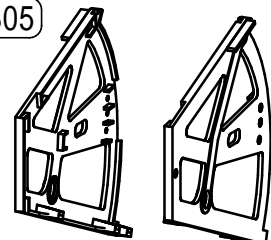

6

erstellt

geändert

geprüft

Datum:

Datum:

Datum:

Montageschritte - ordre de montage - assembly instructions

6.

6.1

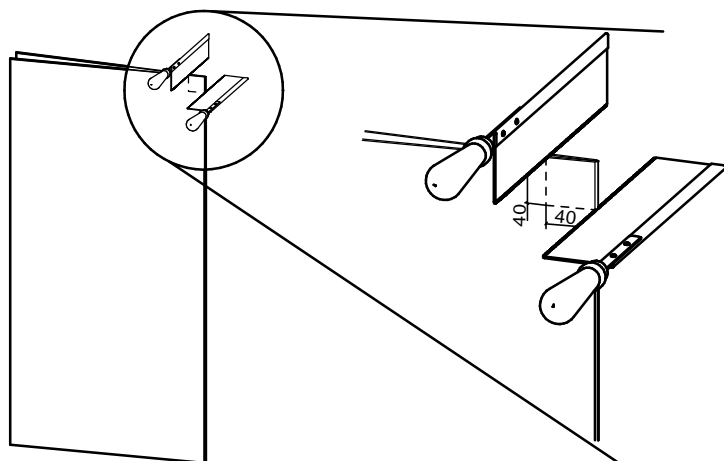

6.2

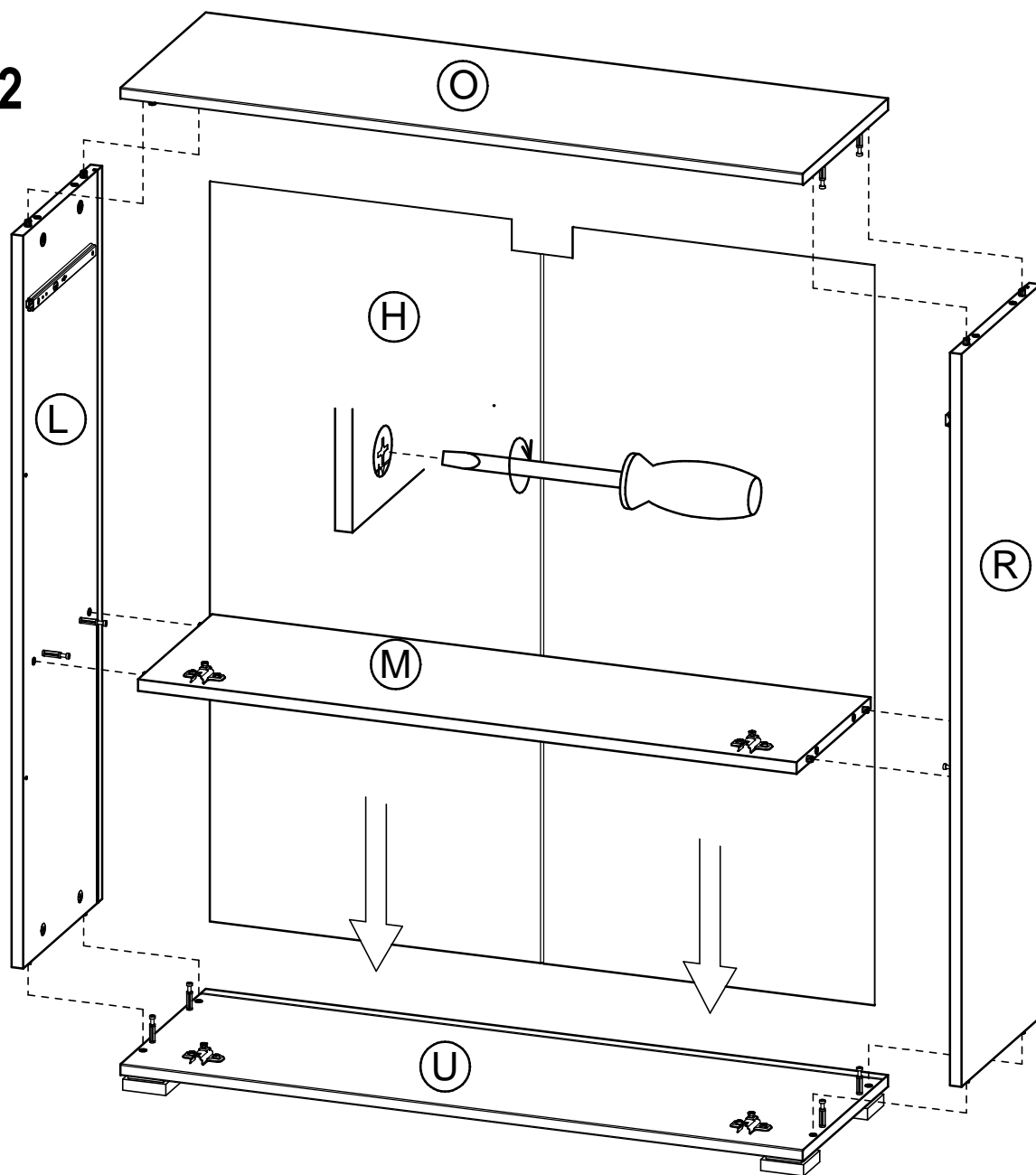

7

erstellt

geändert

geprüft

Datum:

Datum:

Datum:

Montageschritte - ordre de montage - assembly instructions

7.

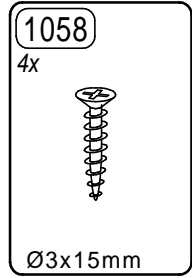
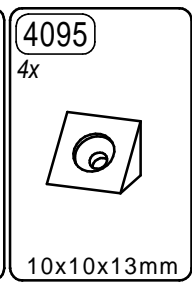
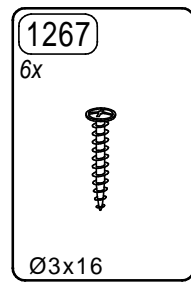
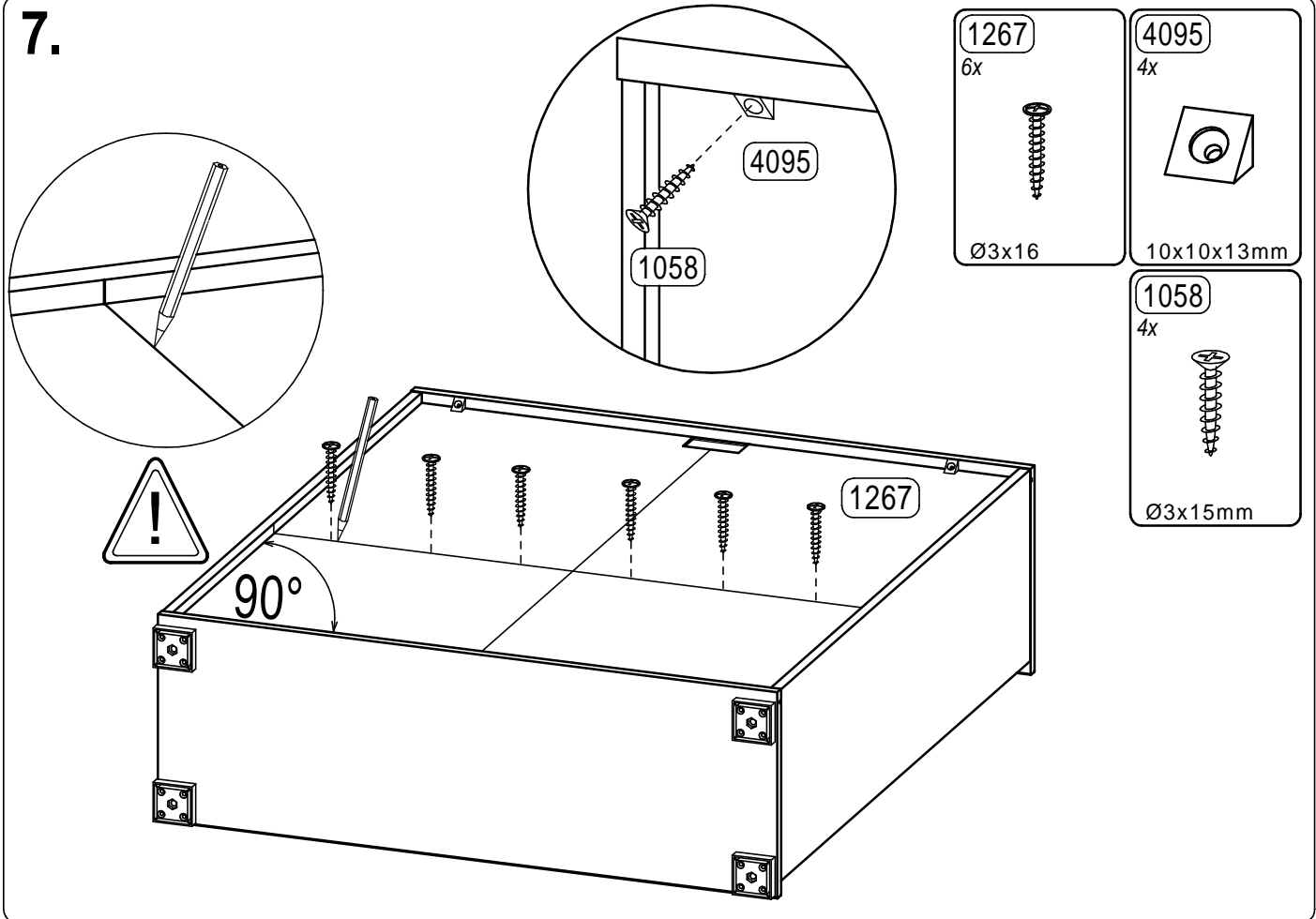

8.

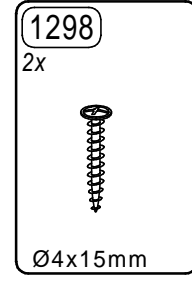
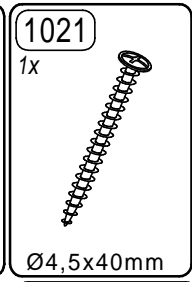
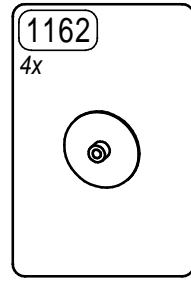
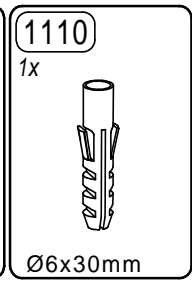
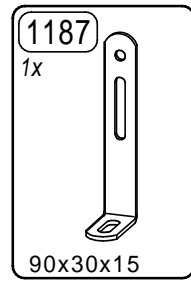
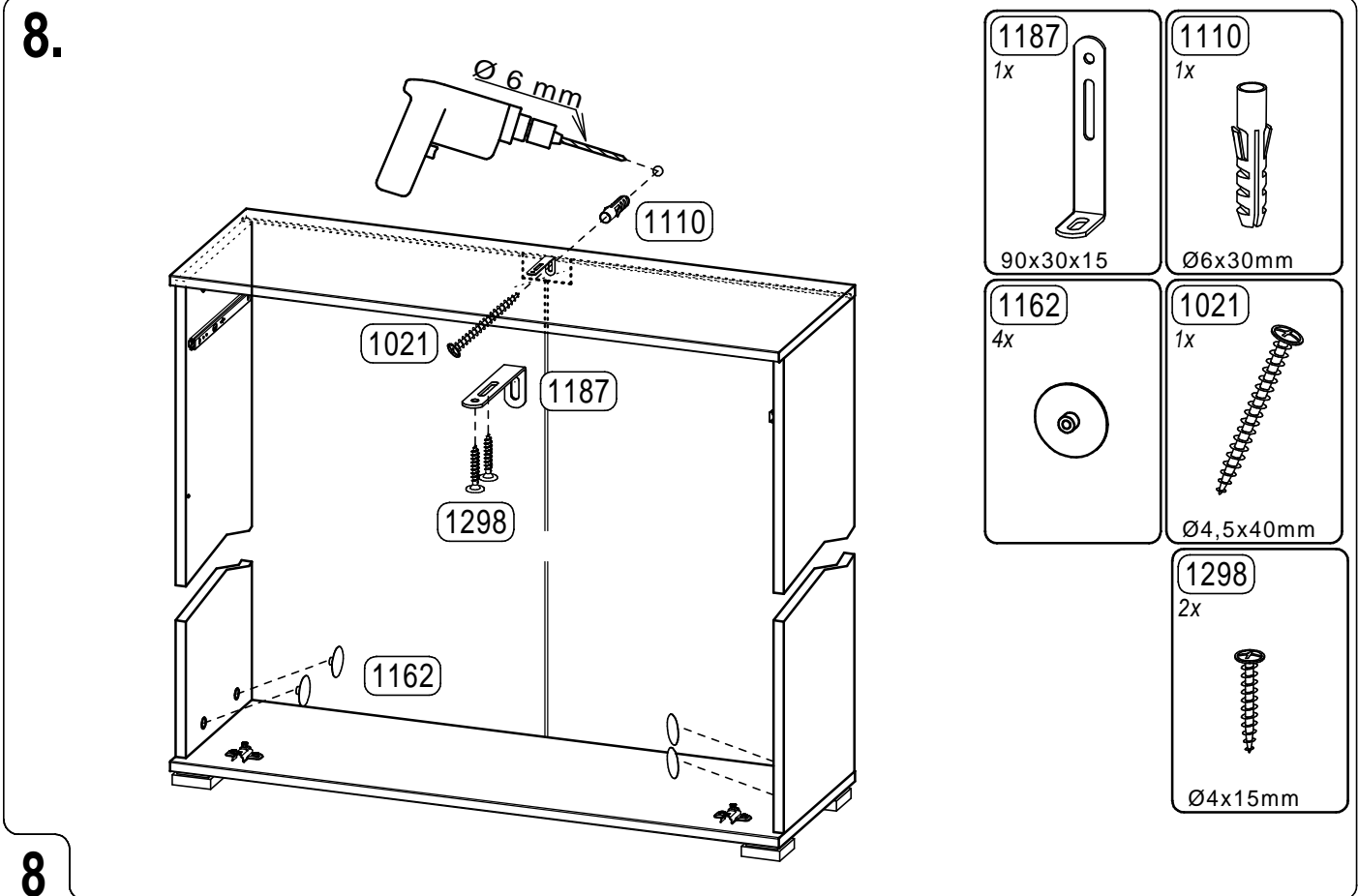

8

erstellt	geändert	geprüft
Datum:	Datum:	Datum:

Montageschritte - ordre de montage - assembly instructions

9.

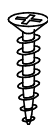
1058
4x

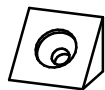
Ø3x15mm

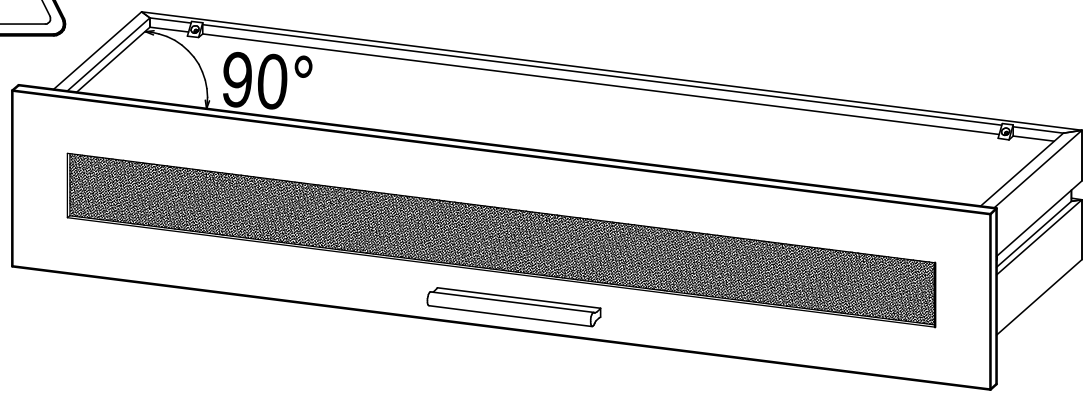
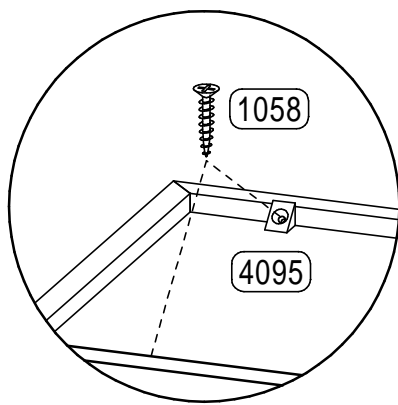
4095
4x

10x10x13mm

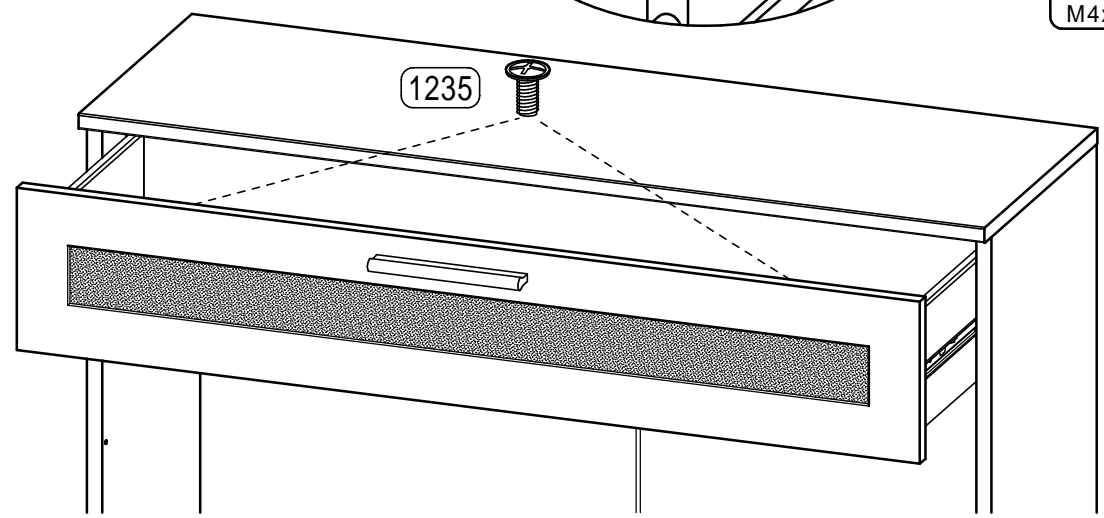
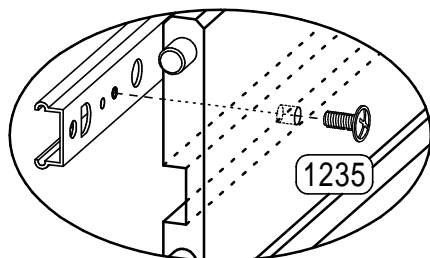

10.

1235
2x

M4x8

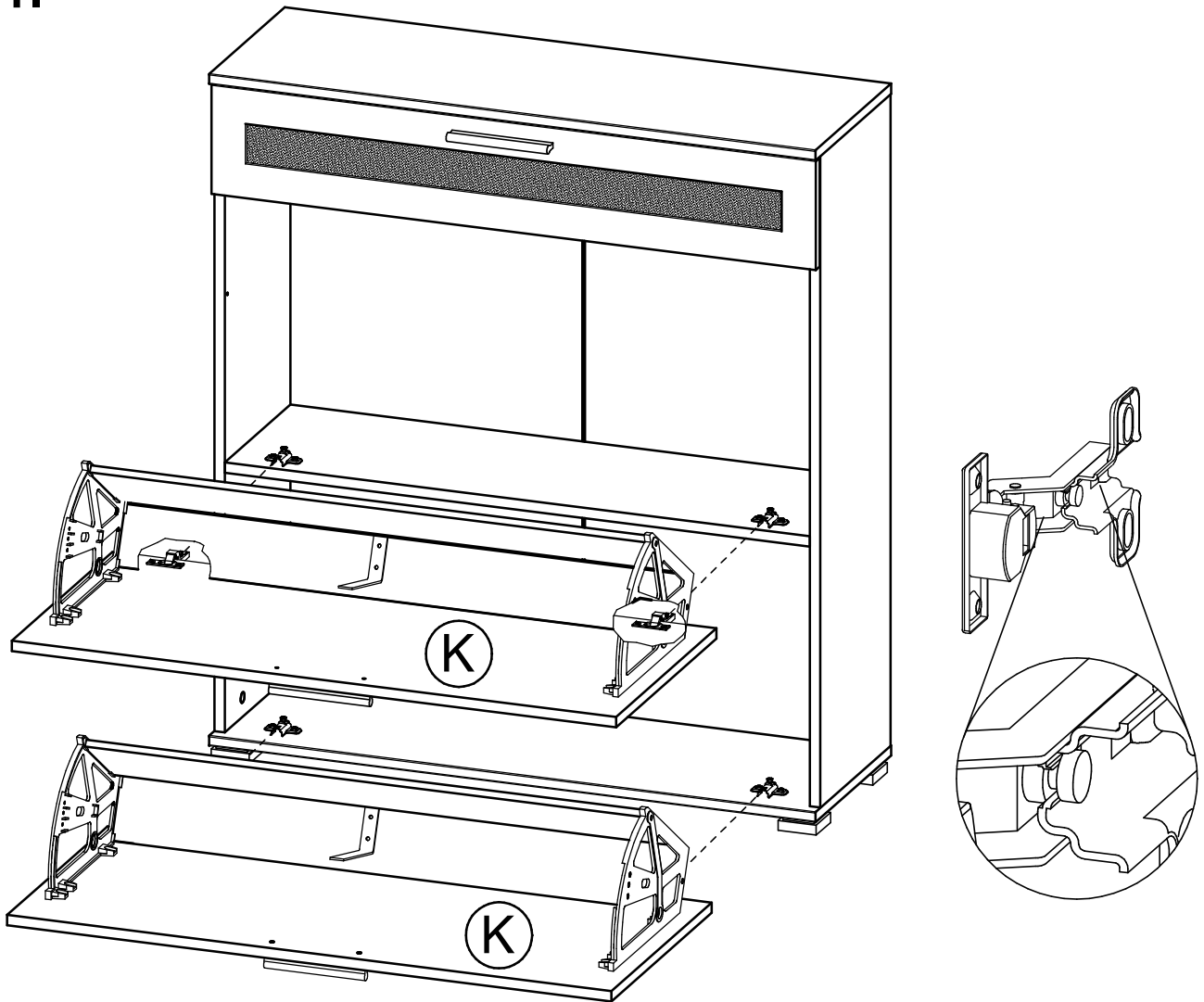

erstellt	geändert	geprüft
Datum:	Datum:	Datum:

11.



12.

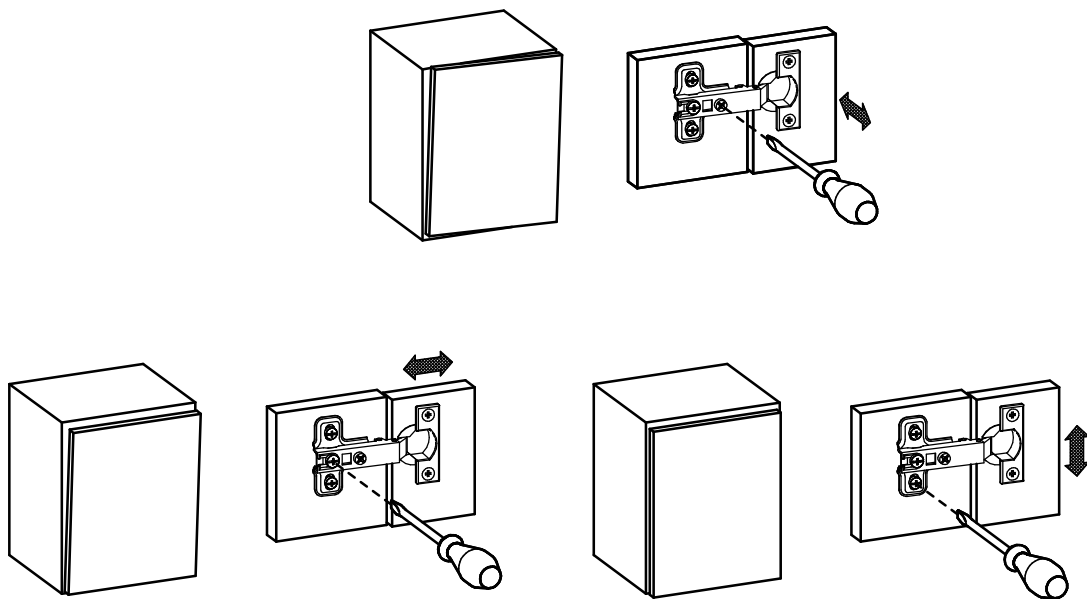

10

erstellt		geändert		geprüft	
Datum:		Datum:		Datum:	

Montageschritte - ordre de montage - assembly instructions

13.

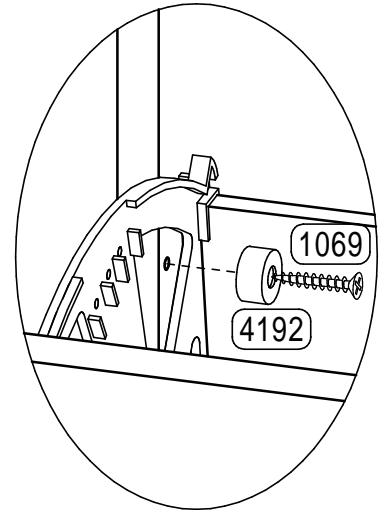
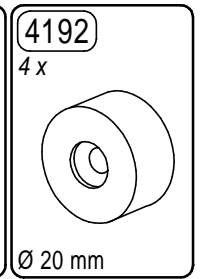
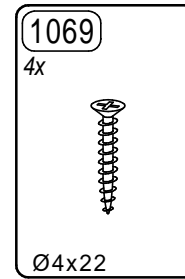
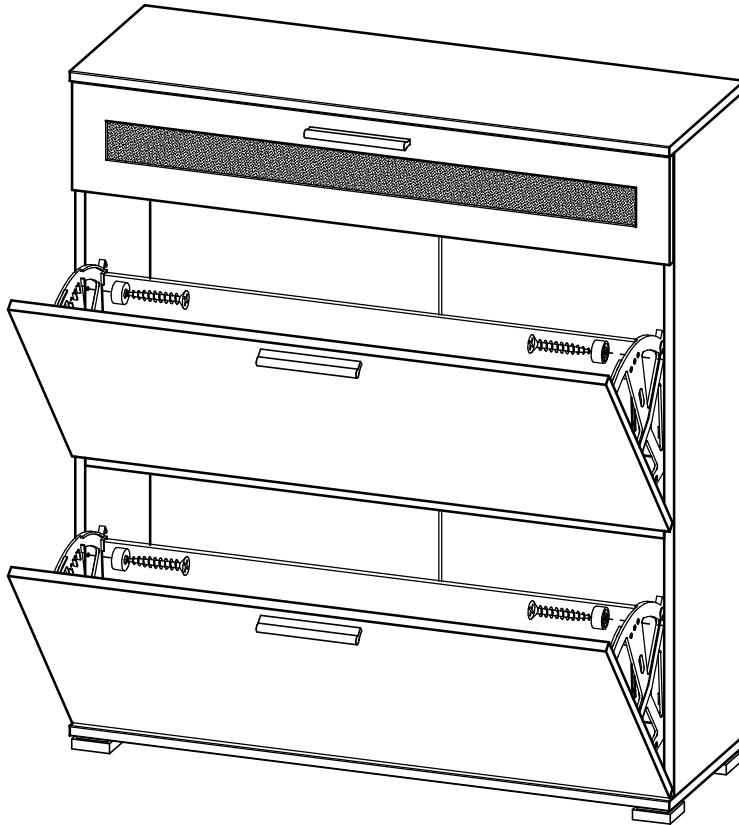

14.

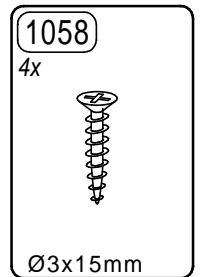
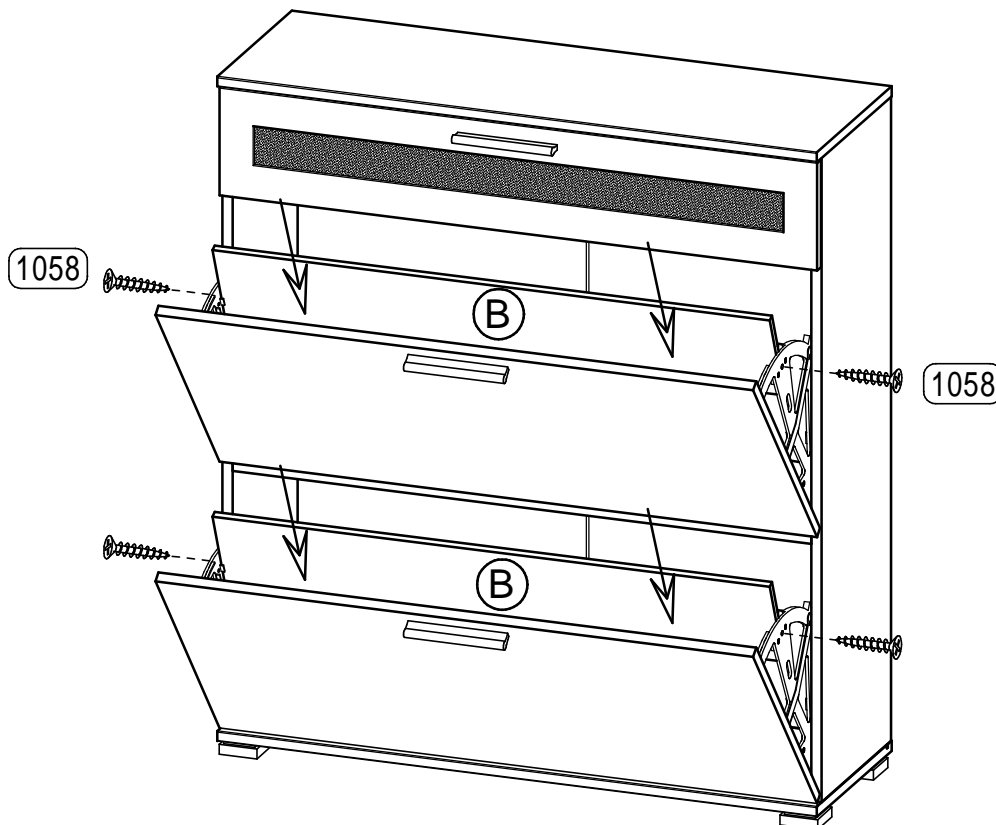

11

erstellt	geändert	geprüft
Datum:	Datum:	Datum:

Ersatzteil-Direkt Service

(nur für Deutschland - for germany only - seulement pour Allemagne)

Sehr geehrter Kunde,
sollte ein Möbelteil bzw. Beschlagteil fehlen oder beschädigt sein, senden Sie uns den Artikel bitte **nicht** zurück, sondern fordern Sie der Einfachheit halber Ersatz direkt bei
Tragen Sie Ihren Bedarf in die Tabelle ein und übermitteln Sie uns diese Seite per Post, per Fax, telefonisch oder per e-mail.
Bitte unbedingt die MODELL-Nr. + DEKOR-Nr. (siehe Karton) und die entsprechende Teilebezeichnung (siehe Teileliste) angeben.



Mod. Nr.: _____ Dekor-Nr.: _____

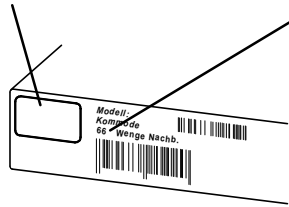

Möbelteile			
Teil	beschäd.	fehlt	Anzahl
Z	X		1

Beispiel

Beschlagteile			
Teil	beschäd.	fehlt	Anzahl
		X	2

Beispiel

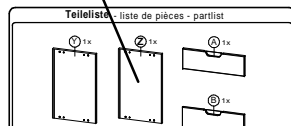

Absender nicht vergessen :

Name:	Strasse u. Nr.:
PLZ:	Ort :
Tel.:	Fax: e-mail:

Unsere Hotline :

Sicherheitshinweise Safety instructions Indications de sécurité



- 1.) Montageanleitung aufmerksam durchlesen
Please read assembly instruction carefully
Prière de bien lire la notice de montage du début à la fin
- 2.) Montage nach Montageanleitung durchführen
Please follow the assembly instruction step by step
Bien suivre le sens du montage indiqué sur la notice
- 3.) Montageanleitung aufbewahren
Please save the assembly instruction
Bien conserver la notice de montage

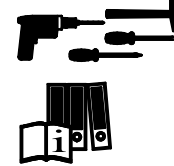

ACHTUNG! Beschlagbeutel und Beschlagteile von Säuglingen und Kindern fernhalten
ATTENTION! To avoid suffocation keep plastic bag away from children
Contains small parts which may be a choking hazard
ATTENTION! Toutes les pièces détachées livrées dans le colis être mis hors de portée des bébés des et enfants

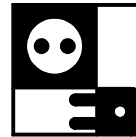

Netzanschluss (230V) nur von einem Fachmann ausführen lassen.
Sanitäranschluss nur von einem Fachmann ausführen lassen.
Mains connection (230V) has to be done by an expert.
Sanitary installation has to be done by an expert.
L'électricité (230V) uniquement à faire par un électricien.
Installation sanitaire à faire par un spécialiste.

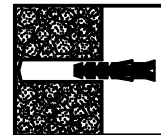

Beiliegendes Befestigungsmaterial eignet sich nur für Massivwände.
Für andere Wände müssen Spezialdübel verwendet werden.
Die Festigkeit ist zu Prüfen.
The attached fixing materials is only suitable for solid walls.
For other Types of walls special dowels have to be used.
The firmness have to be checked.
Le matériel defixation ci-joint est exclusivement prévu pour des murs pleins(une fixation spéciale est nécessaire pour cloisons placo...)
La fermeté est à examiner.



Beiliegende Wandbefestigungen dienen als Kippschutz, unbedingt anbringen!
The attached wall fixing is necessary to avoid tipping and must be fixed!
Les fixations prévues dans le colis préviennent contre le renversement du meuble. Il faut impérativement fixer le meuble au mur, afin d'éviter tout incident!

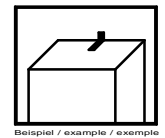

Für Schäden, die durch unsachgemäße Montage entstanden sind, übernehmen wir keine Haftung
For the damages, which have originatet prom improper assembly, we take over no liability.
Pour les dommages qui sont nés par le montage incorrect, nous ne prenons en charge aucune responsabilité.