

# WALLBED

## Assembly Instructions

### **First – a few words of advice and caution:**

1. Please do this job with two people. Attempting to do it alone, though heroic, could lead to product damage or injury because some things can be too heavy for just one person to safely handle. With two people, the job will be much smoother and safer.
2. Please read and follow the instructions carefully, as it will save time and avoid possible incorrect installation of the product.
3. Please do not over-tighten screws and bolts, as it may lead to “stripping” the threads and make the connection weak. The best rule of thumb is “snug is good”.
4. If you will be installing your Murphy Bed on a hard surface such as stone, hardwood floor, tile, (not carpet), please lay down sufficient padding (such as blankets, comforters, etc.) to protect the wood parts of your wallbed from the floor, and vice-versa.

# PREPARATION FOR ASSEMBLY:

Please locate and confirm that you have the following 5 boxes.

WALLBED – BOX LIST – Queen Size		
BOX #	SKU#	DESCRIPTION
1		Horizontal Case Panels and Spring Cover
2		Vertical Case Panels
3		Iron Spring Base Wall Frame and H Mount Frame
4		Wallbed Left Euroslat Tray
5		Wallbed Right Euroslat Tray

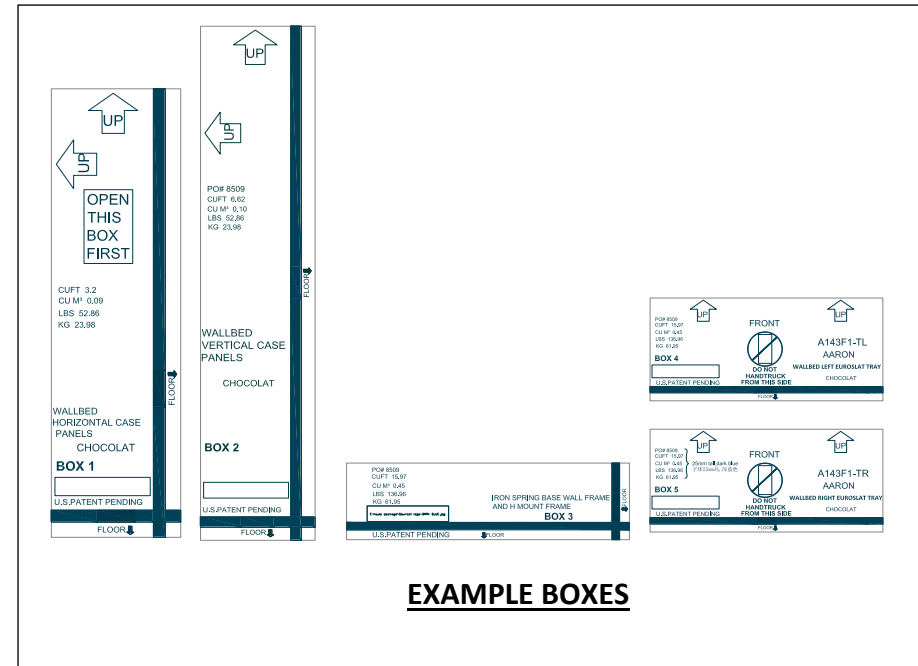

**EXAMPLE BOXES**

- A. Please locate the “Hardware Parts List” included with these instructions.
- B. Please carefully open and un-pack box #1.
  - a. Inside you will find 3 horizontal panel parts and Bubble Pack #1 – which has tools and connectors.
  - b. Please carefully sift through the debris field of each carton you open to make sure no hardware parts came loose in shipping.
- C. TOOLS YOU NEED TO SUPPLY:
  - a. A power drill gun with a #2 Phillips-head drive is required.
  - b. A flat-head screw driver is required.
  - c. A pair of pliers will be very helpful.
- D. Please be aware that further hardware parts will appear in other boxes as the Assembly Project progresses.

## STEP 1: SETTING UP THE BED CASE

FROM BUBBLE PACK #1, FOUND IN BOX #1, Please use the 11 bolts and barrel nuts, along with the #5 Allen Wrench and/or #5 Allen Head for Power Drill (the larger ones) to assemble the Bed Case as shown below.

**1A** – Lay out the parts from boxes 1 and 2 as shown. YOU ARE BUILDING THE BED CASE FACE-DOWN. The notches in the back of the side panels must be toward the wall where the bed will go, and 20 inches away from the wall.

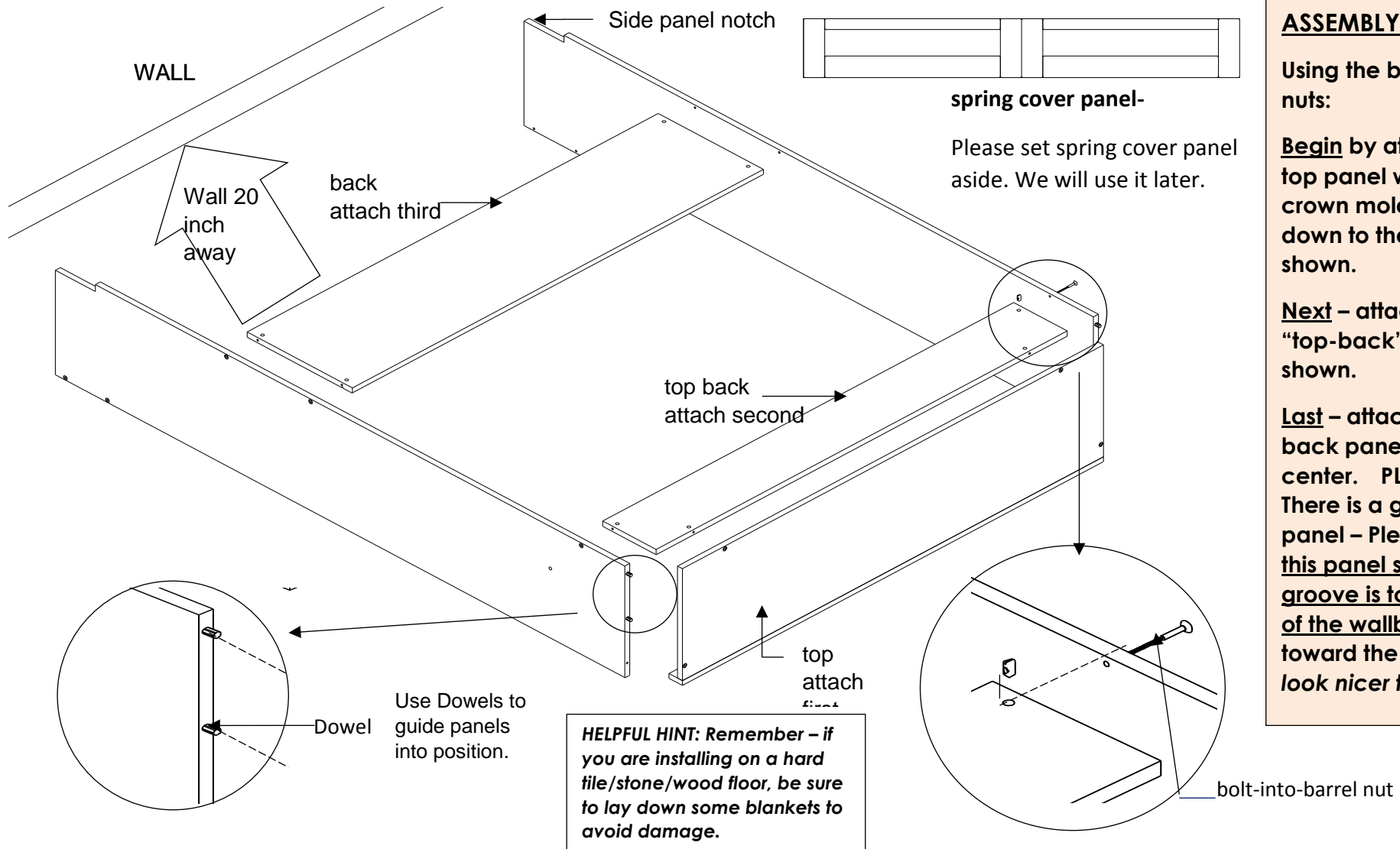

### ASSEMBLY SEQUENCE

Using the bolts & barrel nuts:

**Begin** by attaching the top panel with the top crown molding facing down to the floor as shown.

**Next** – attach the small “top-back” panel as shown.

**Last** – attach the larger back panel in the center. PLEASE NOTE: There is a groove in this panel – Please orient this panel so that the groove is toward the top of the wallbed and NOT toward the wall. (It will look nicer that way.)

**1B**– Stand the assembled Bed Case up and move to the desired position against the wall. Use screws to install the door stops from Bubble #1 on bed case side panels.

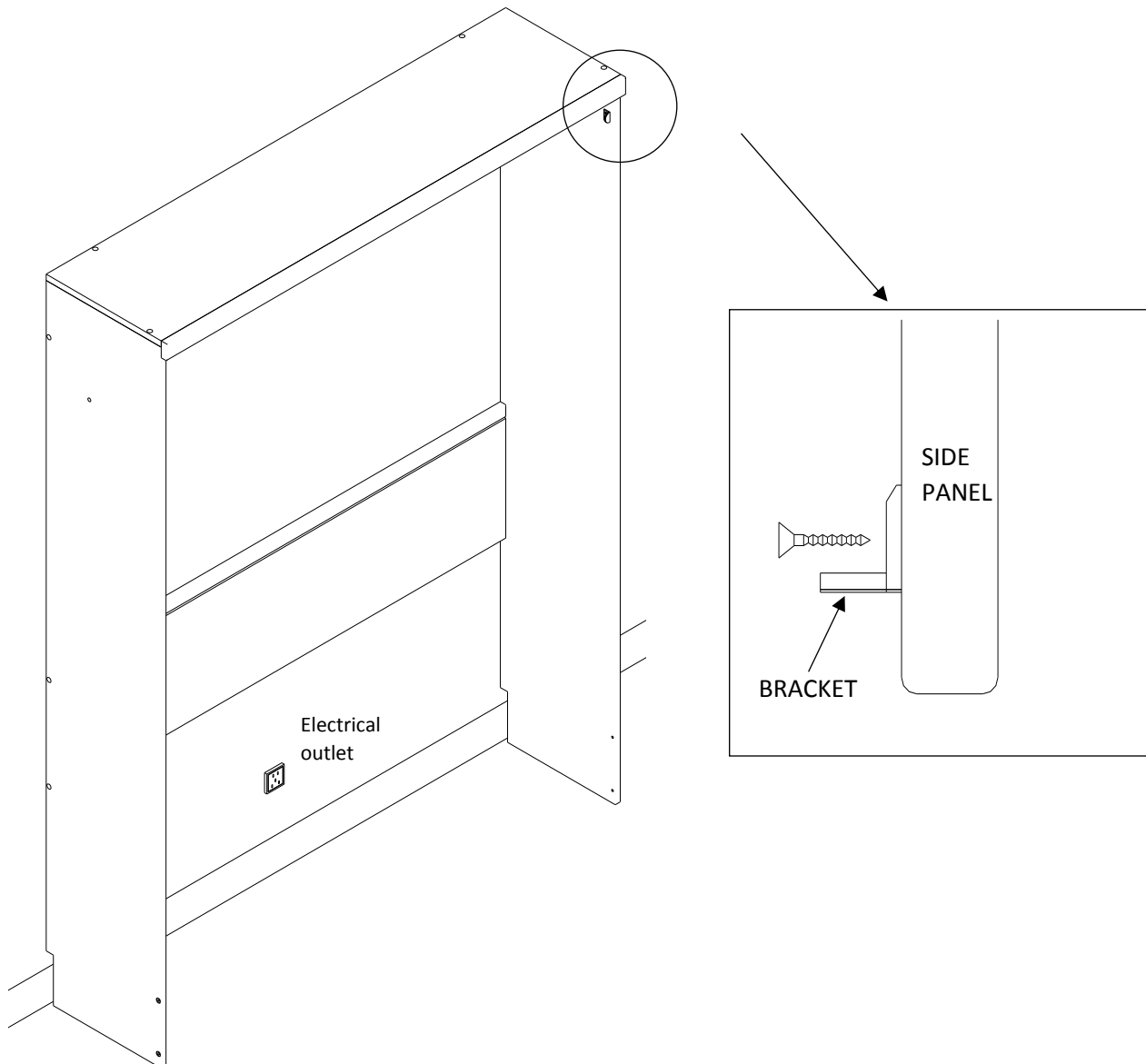

### OPERATION SEQUENCE

*(Before you do this – check AGAIN that there is at least 20 inches from the wall to the side panels.)*

**Begin** with TWO PEOPLE standing at the top corners of the bed case.

**Next** – Each person grasps the top crown molding with one hand.

**Next** – **LIFTING WITH YOUR LEGS – NOT YOUR BACK** – stand the bed case up.

**Next** – Grasping the side panel on each side, carefully lift and adjust the bed case back to the wall.

**Last** – Measure space on either side for Bookcases (if purchased). Stand back and assure that you like how the wallbed looks there. Gently lift and make adjustments as needed.

**BE SURE** – Take your time, because you're not going to want to move it again once it is fully installed.

## **STEP 2: SETTING UP AND INSTALLING THE SPRING BASE**

The best results will be achieved by following these instructions carefully.

TOOLS YOU WILL NEED TO SUPPLY:

1. A power drill gun with a #2 Phillips head,
2. A tape measure or ruler.

**STEP 2A** – Please measure the thickness of your base molding as shown on the figure here:

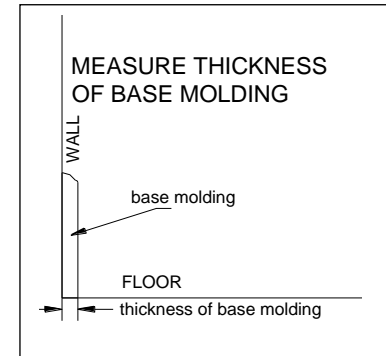

5

Please write this English Fraction or Millimeter measurement here \_\_\_\_\_, we will use this number in a few minutes.

**STEP 2B** - In box # 3, please collect the spring carriage frame, the left and right flange arms, the two spacer-brackets, (and if you have no baseboard, you will also need the two flange spacer blocks.) From bubble pack #2, please take out the 4 wing bolts.

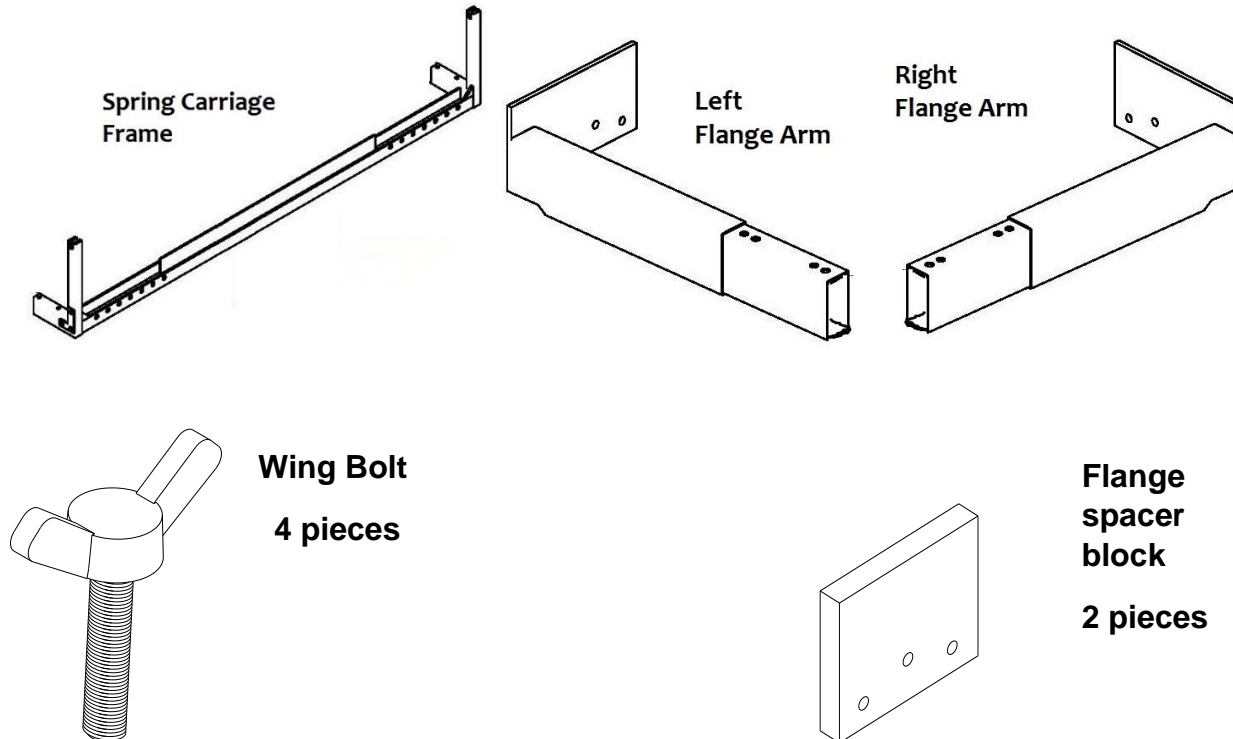

### ***Helpful Hint:***

*If you are installing on a hard floor – you may have a small half-inch round molding at the bottom of your baseboard. This smaller molding will have to be cut and removed where the left and right flanges will touch flush against the baseboard.*

**STEP 2C** – You will notice that the left and right flange arms can be attached to the spring carriage in two positions – and this is where the base-board thickness measurement comes in:

**OPTIONS:**

1. If you have no base board or 1/4" baseboard – you will use the pre-drilled wood Flange Spacer Blocks – and you will use the “extended” position.

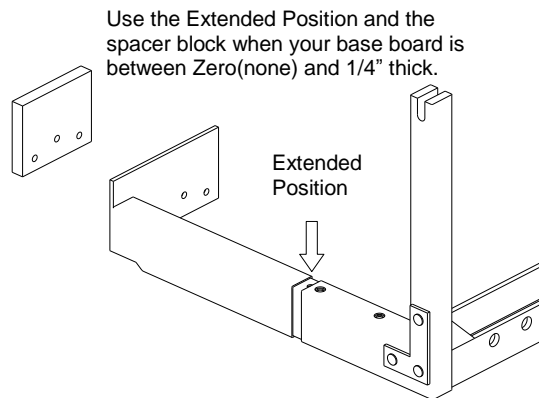

Use the Extended Position and the spacer block when your base board is between Zero (none) and 1/4" thick.

This is the correct Technique when you have:

1. No baseboard
2. A thin plastic coped runner
3. A carpet toe-kick
4. A wooden baseboard less than 3/8" thick.

**Helpful Hint:**

***DO NOT*** use the Wing bolts yet – this page is **ONLY** about figuring out the correct way to configure the Spring Base!

2. If your base board is 1/4" to 3/8 inch – you will use the “extended” position without the Flange Spacer Block.

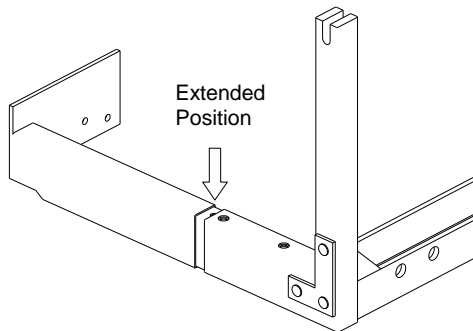

3. If your base board is more than 1/2 inch – you will use the “tight” position.

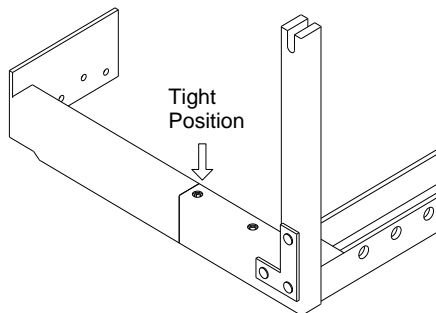

**STEP 2D** – Connect Flange arms to the Spring Carriage Frame using the four Wing Bolts, and

Carefully place the Spring Carriage Frame into the bed case (don't scratch the wood)

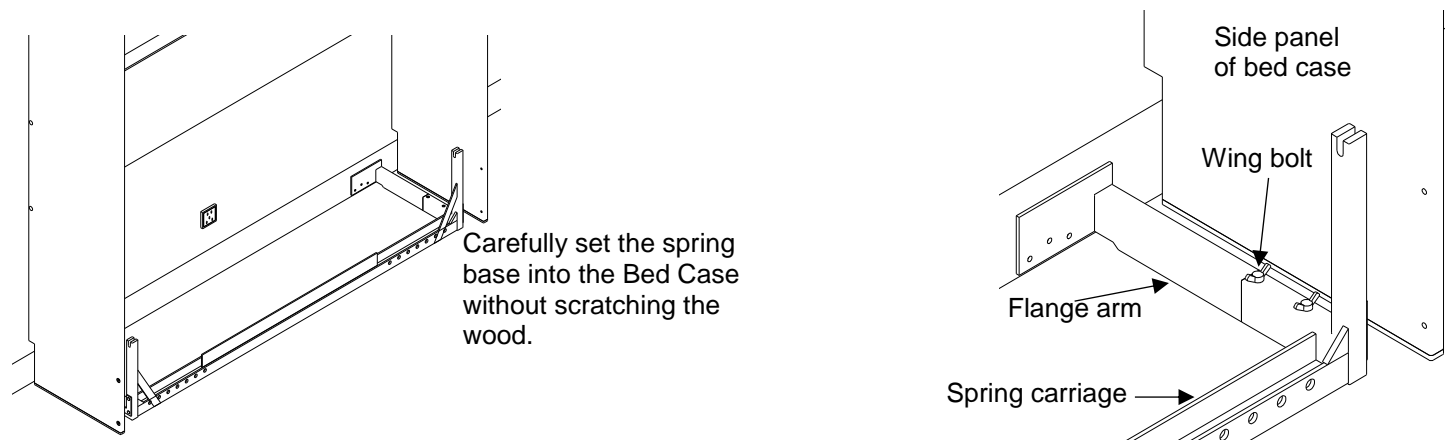

**STEP 2E**- Install the assembled Spring Base into the “Base Plate” at floor level inside your wall.

First – A word about the “Base Plate”.

Most everybody knows what a “two-by-four” is; it’s a piece of wood that is about 1.5” thick and 3.5” wide, and usually quite long unless cut. But, unless a person has worked in the construction trades, or seen homes under construction, one would not often know that there is a 2x4 lying flat on the floor inside your walls.

This is the “base plate” that is supporting all the vertical 2x4’s that are behind the drywall or plaster in your walls. This base plate is nailed into the floor, and with all the vertical 2/4’s on top of it – which end up carrying the weight of the roof – the base plate has the entire weight of the house resting on it.

We are going to hang your wallbed on the base plate – which is a very, very stable and virtually immovable part of your house.

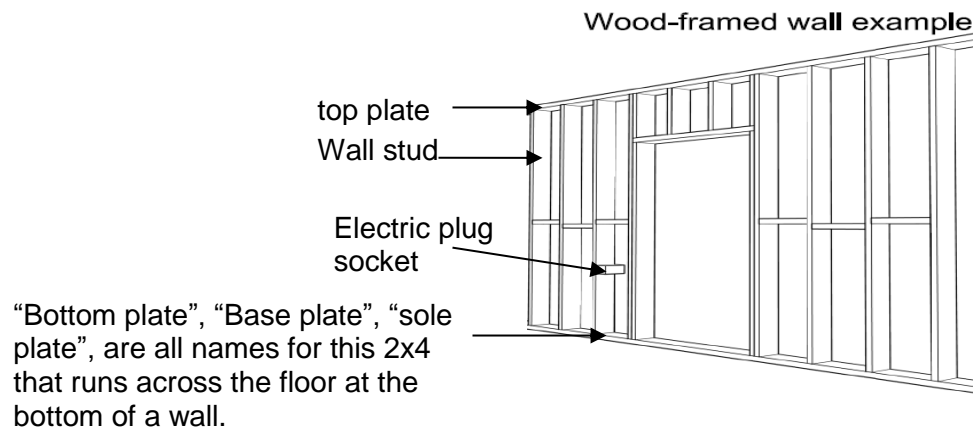
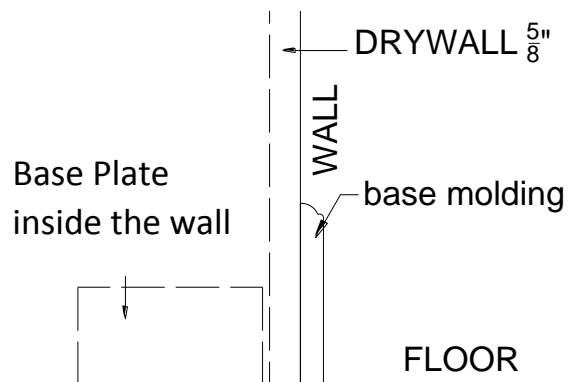

**STEP 2F**– Use the Anchor Screws in bubble pack #2 to connect Flange Arms to the Base Plate.

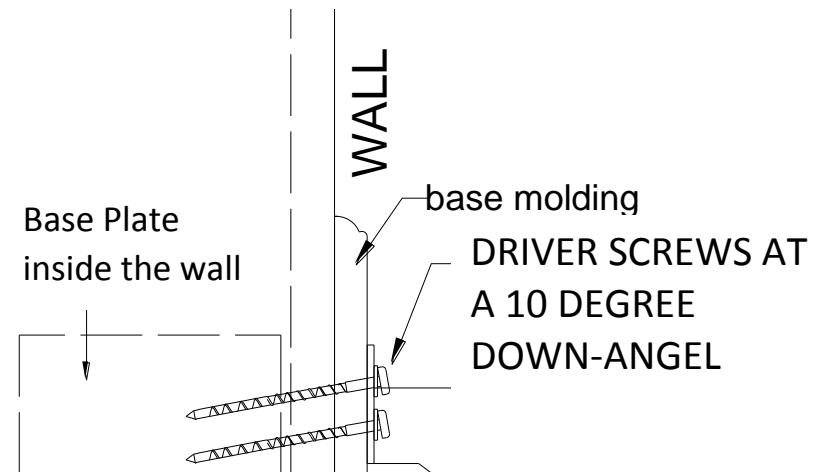
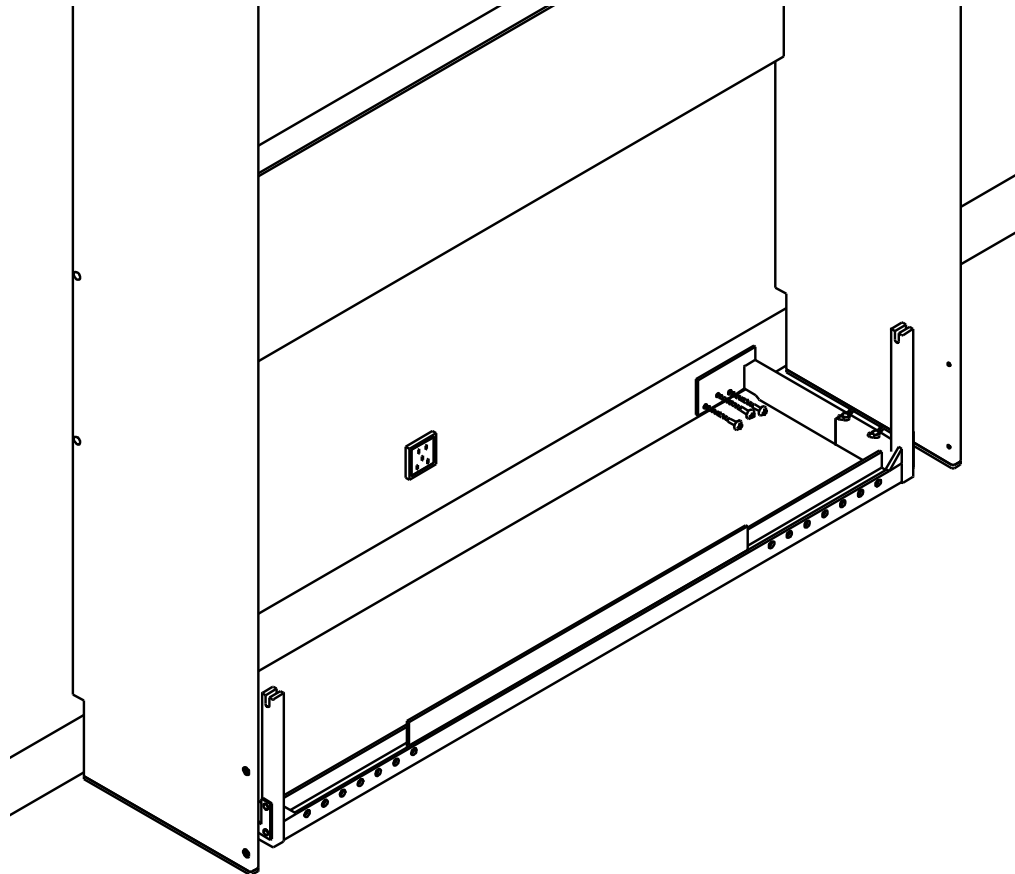

IF YOUR BASE MOLDING IS SOLID WOOD .....  
PLEASE USE A 1/8" DRILL BIT TO PRE-DRILL THROUGH THE BASE MOLDING ONLY (NOT BASE PLATE) TO REDUCE THE CHANCE OF SPLITTING YOUR BEAUTIFUL WOOD MOLDING



### STEP 3 – Building the Bed Frame

STEP 3A – Install metal frame from boxes 3, 4, and 5, and connect them with the connection hardware in bubble #3.

9

① lay metal as shown

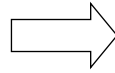

② using long bolt connect  
left/right tray frame at the  
top and bottom of the tray

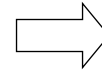

③ Using short bolt connect  
metal plate and T tube

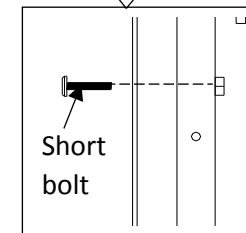
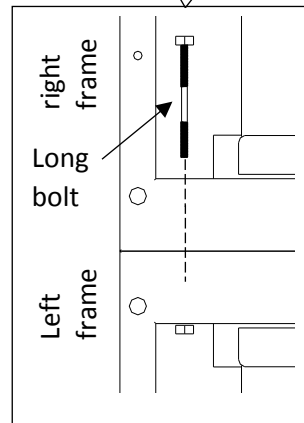
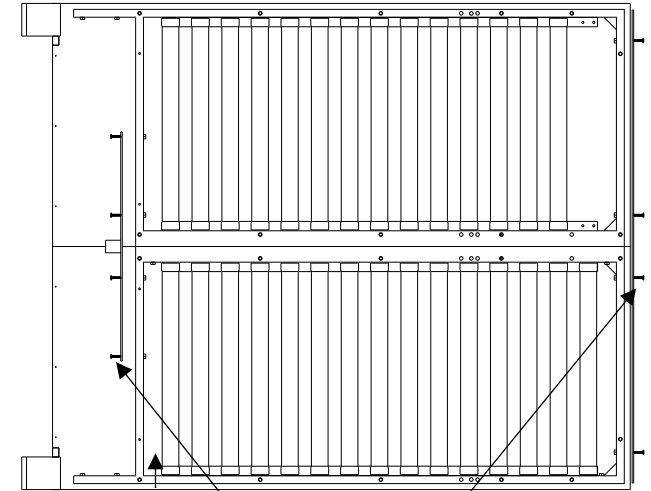
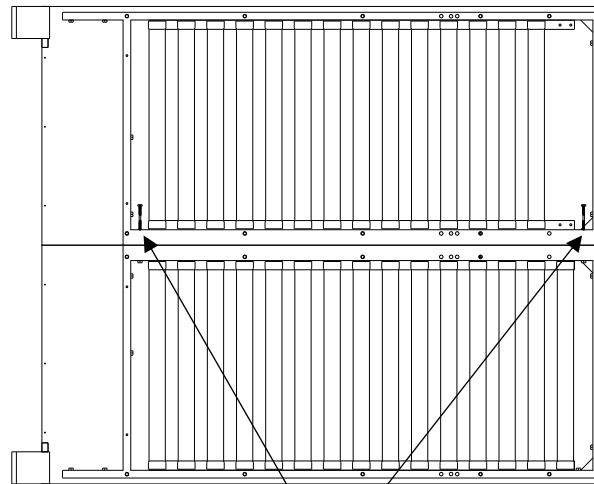
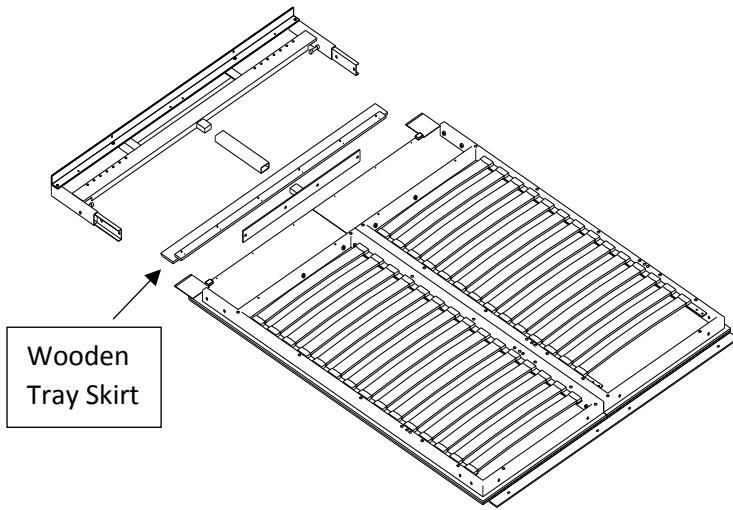

④ Using screws, connect the wooden tray skirt



⑤ Install H-FRAME using short bolts to connect it

Wooden Tray Skirt

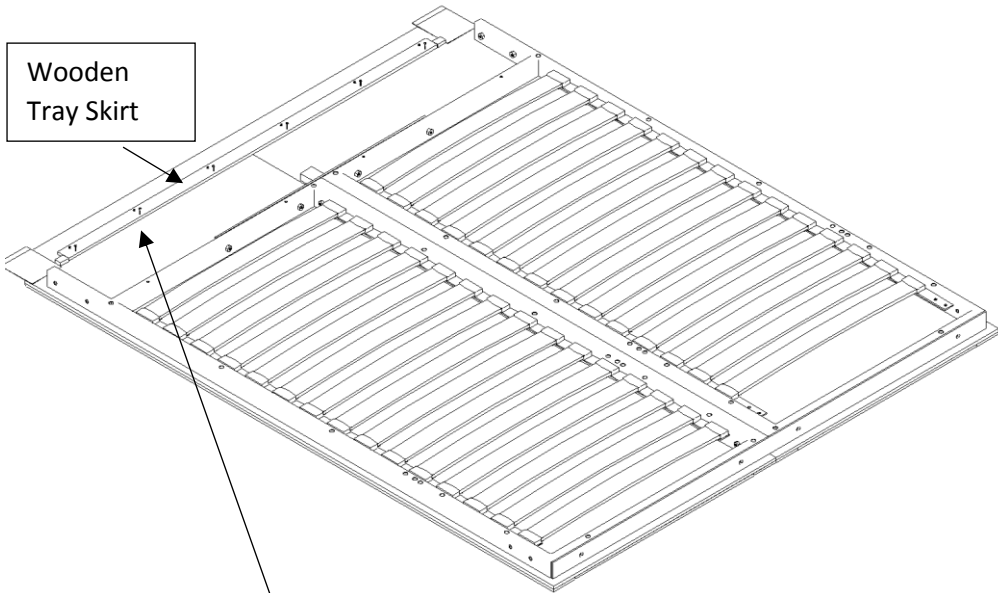

Wooden Tray Skirt

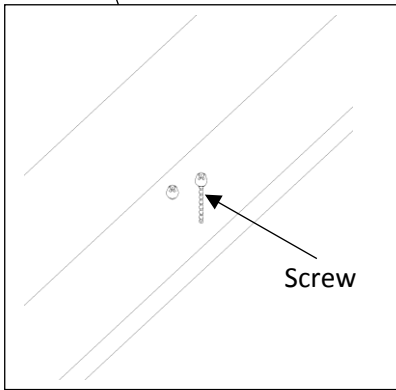
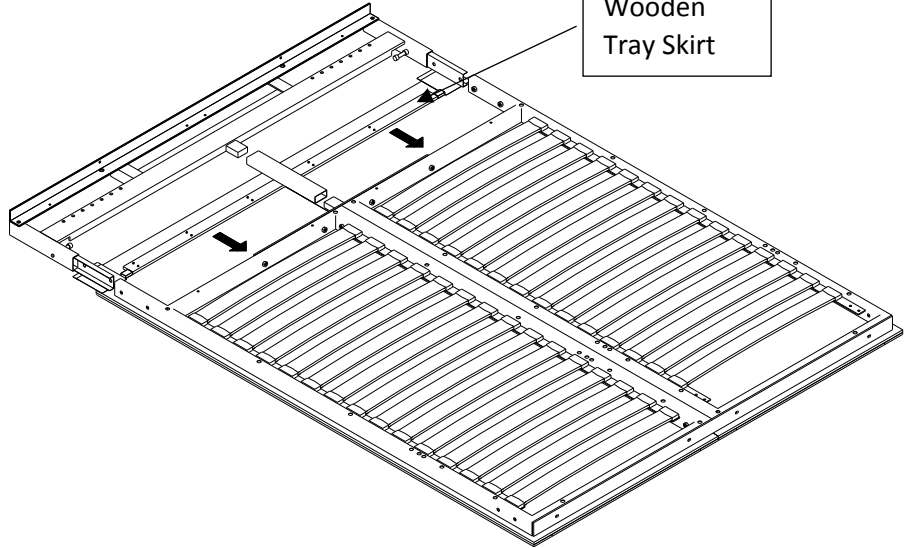

Screw

Install the Wooden Tray Skirt on the back side of the Bed Tray Panels

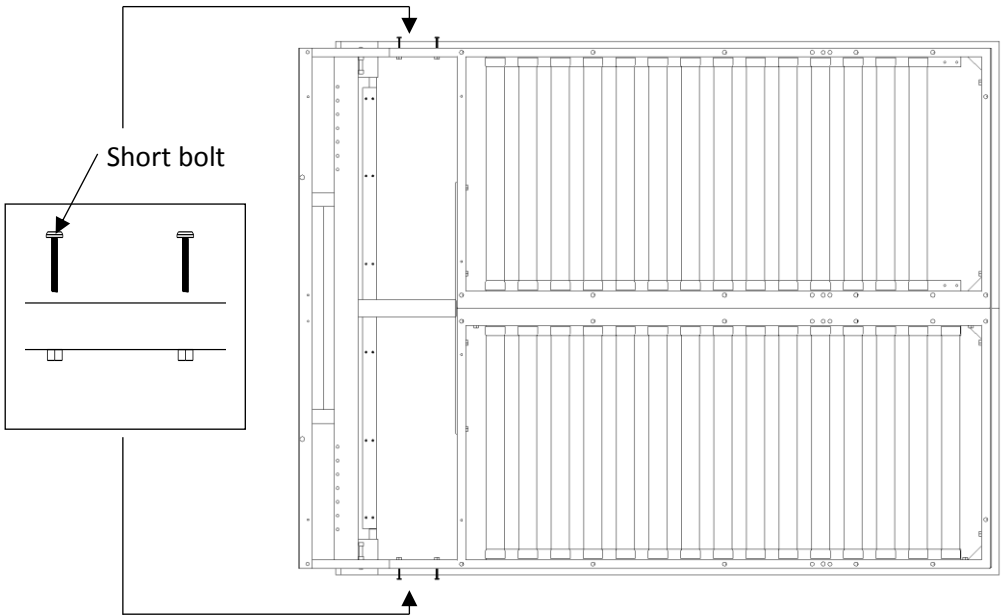

Short bolt

**STEP 3B** – Install the 2-piece flat deck from boxes 4&5 and attach the mattress hoop and flip-over feet from box 3 to the bed tray as shown here, and connect them with the connection hardware in bubble pack #3. Using the wrench and #4 Allen tools from bubble pack #1, install the door handles from box 1.

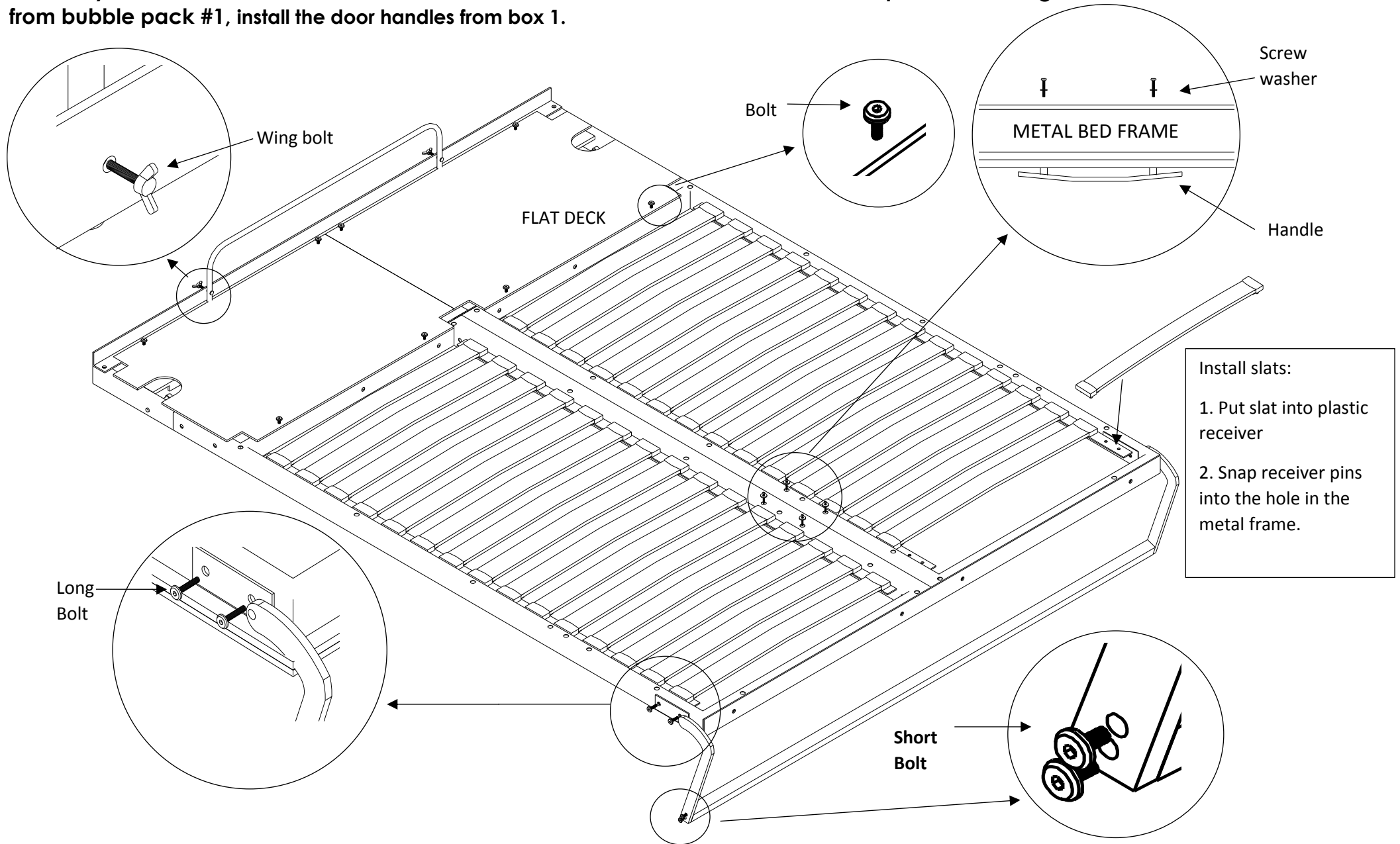

**STEP 3C**– Install the assembled bed frame onto the spring carriage frame by dropping the pivot pin into pivot post.

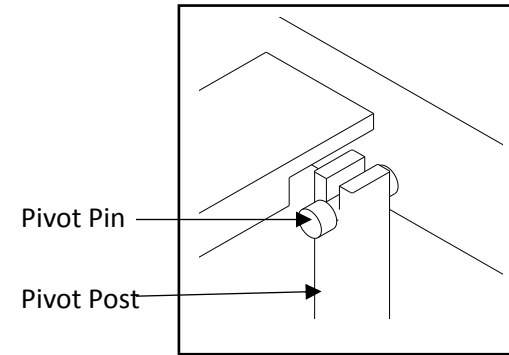
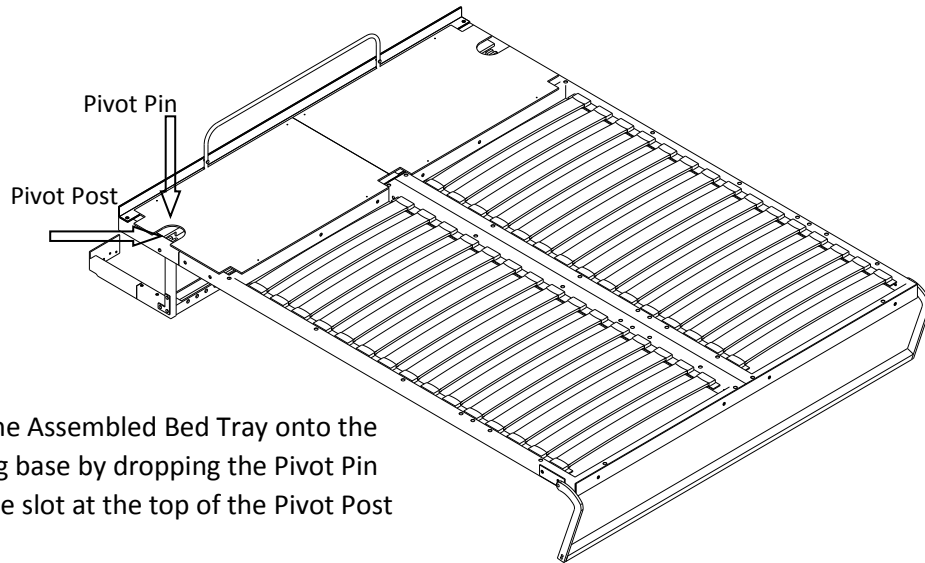

Set the Assembled Bed Tray onto the spring base by dropping the Pivot Pin into the slot at the top of the Pivot Post

**STEP 3D** – PUT YOUR MATTRESS ON THE DECK, then flip the foot bar up and over to hold the mattress, lift the bed tray into the bed case and let it settle naturally against the back. Install the springs from box 3. Start with 6 per side using the outermost available connection points.

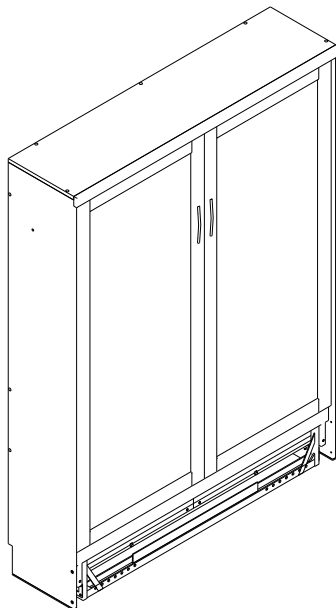

While one person holds the bed tray safely vertical, another person can install the springs

Install springs ONLY with your mattress on the bed tray.

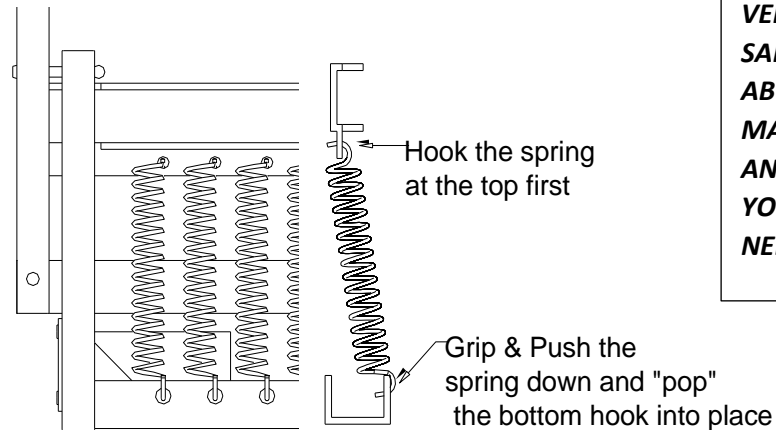

**PLEASE READ SAFETY WARNINGS #1 & #2 ON PAGE 15– WHICH HAVE VERY IMPORTANT SAFETY INFORMATION ABOUT YOUR MATTRESS WEIGHT AND HOW TO MOVE YOUR MATTRESS WHEN NEEDED.**

**STEP 3E** – With the bed tray closed, center the bed case at the top by inserting some folded pieces of cardboard in equal thickness on either side.

**Put equally folded pieces of cardboard in each of the gaps between the flip-over-foot leg and the side panel. This assures the top of the bed case is “squared” with the bed frame.**

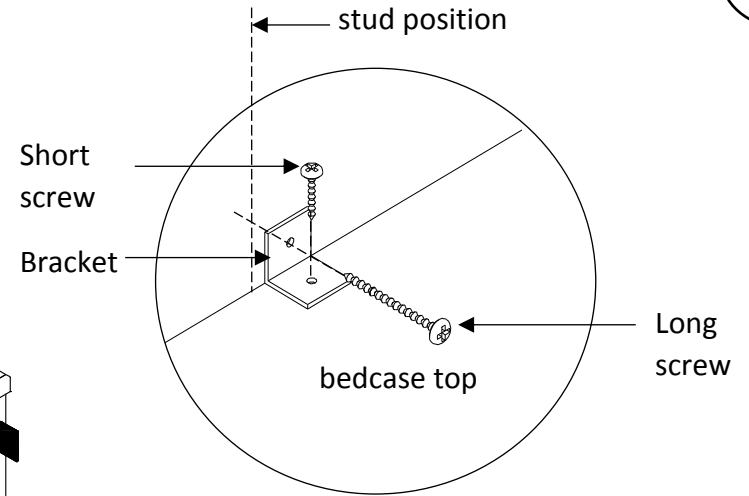
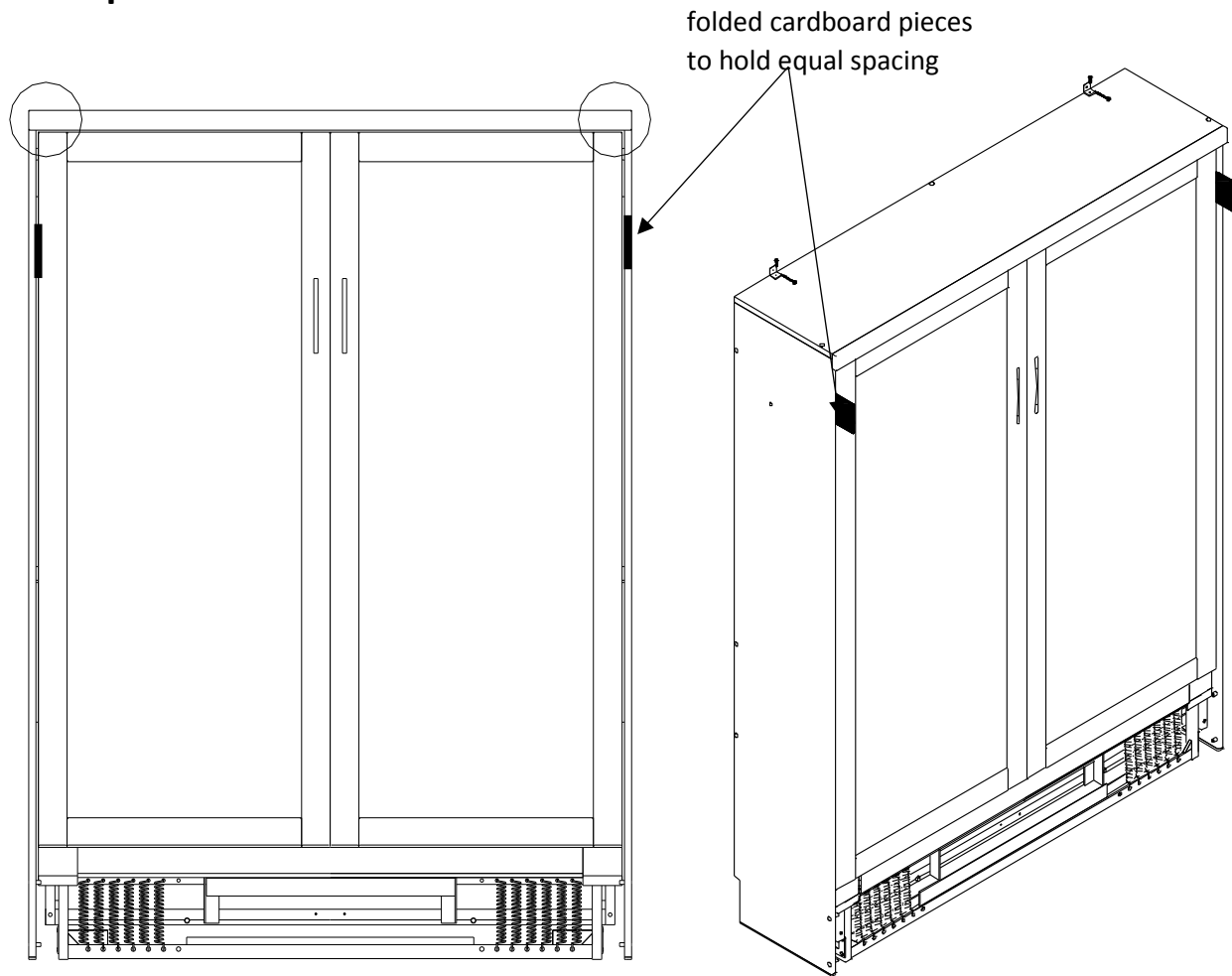

**While the pieces of cardboard hold the bed case “square” to the metal tray, find two vertical studs in the wall and use the small bracket and screws in bubble pack #2 to affix the bed case in position as shown.**

**STEP 3F – Remove the two pieces of cardboard and install the spring cover in box #1 by connecting it with the bolts found in bubble pack #1.**

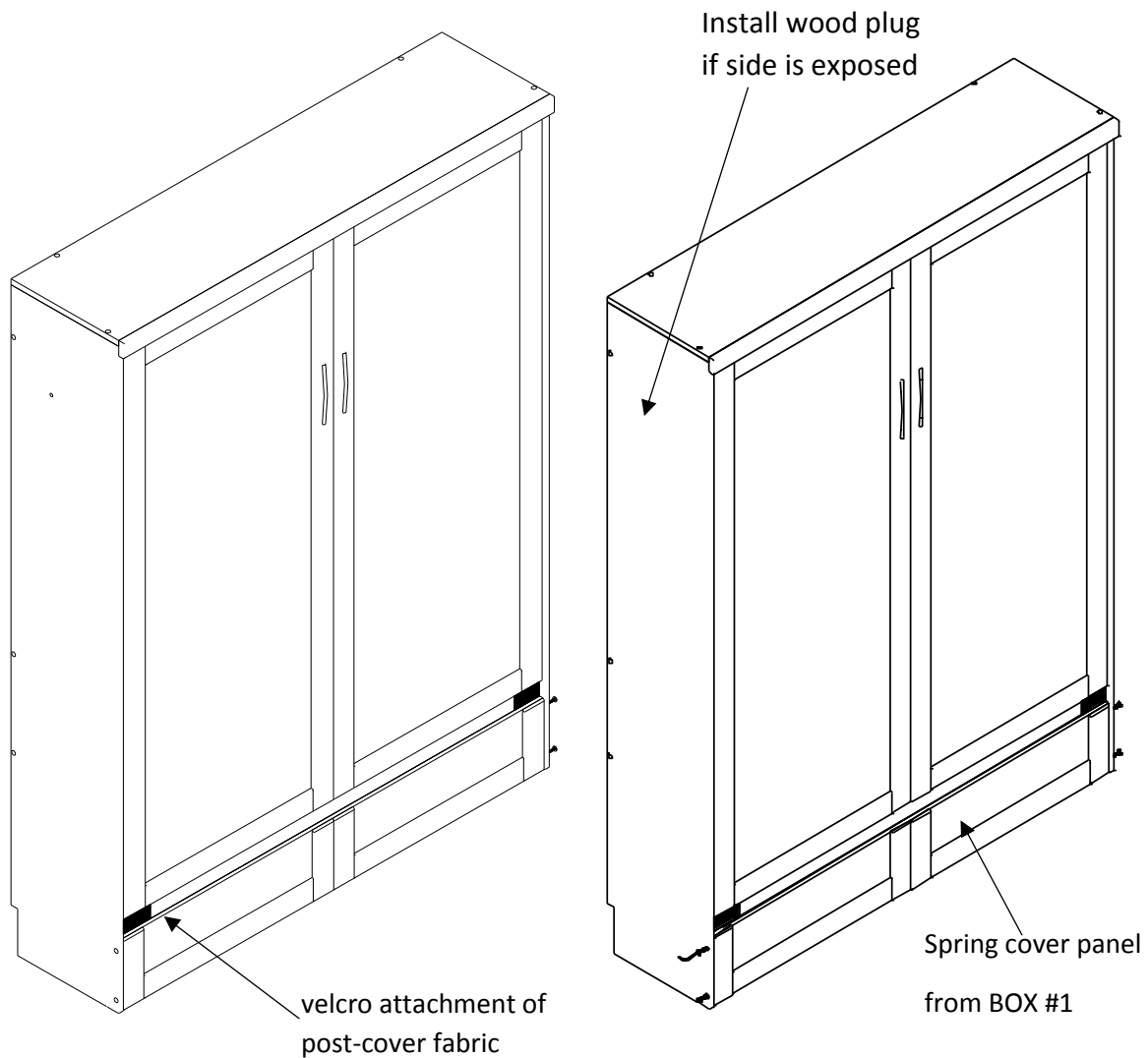

1. If your spring cover has handles or knobs, please install the handles or knobs before installing the spring cover
2. Lay spring cover against the pivot cover cloth, and connect the velcro strips smoothly and evenly (not to worry if you make a mistake, just strip it off and try again). The pivot cover cloth will slightly overlap on each side evenly.
3. Using 2 bolts on each side, attach the spring cover to the bed base.

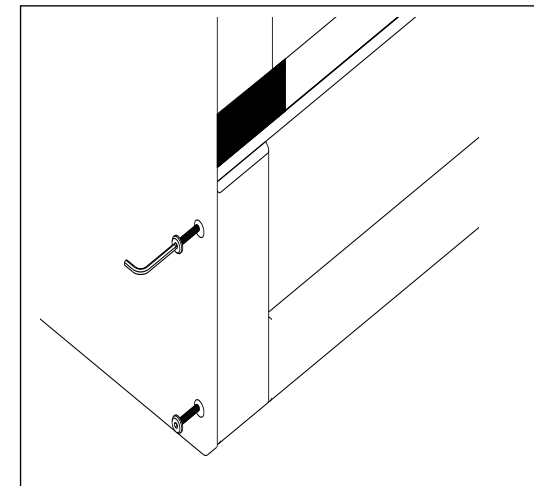

**If you purchased the “deskbed” version – you will find additional parts and instructions in the –DSK box #7.**

**WARNINGS FOR YOUR SAFETY:**

1. THE MAXIMUM RECOMMENDED QUEEN SIZE MATTRESS WEIGHT IS 80 LBS.
2. WHEN MOVING/REMOVING YOUR MATTRESS:
  - a. Once you have completed step 3C, you have installed sufficient springs to make your bed tray move up and down smoothly with your mattress on the bed tray.
  - b. DANGER: If the weight of the mattress were not on the bed tray after you have installed 10 to 14 springs, the springs are strong enough to lift the empty bed tray to the vertical position very quickly – which could result in an injury if a person were struck by the fast moving tray.
  - c. To avoid the chance of injury when removing or changing your mattress, YOU MUST FIRST REMOVE ALL BUT TWO SPRINGS BEFORE REMOVING THE MATTRESS.