

# ASSEMBLY INSTRUCTIONS





## UPH HEADBOARD, 6/6 PLATFORM BED RAIL, 5/0, 6/6 PLATFORM BED UPH FOOTBOARD, 6/6 PLATFORM BED W/ 4 SLATS





**Read instruction carefully prior to assembly.**

Thank you for purchasing this quality product. Check carefully for small parts which may come loose during shipment.

Remove all components from pack and place top down on soft surface such as carpet or cloth to prevent scratching the finish. Identify and count all parts as specified below.

It is recommended to use two or more persons during the assembly process.

HARDWARE LIST				
NO		DESCRIPTION		Q'TY
A		Ø 5/16" X 100	Thread Bolt	8pcs
B		Ø 5/16"	Hex Nut	8pcs
C		Ø 5/16"	Curve washer	8pcs
D		13mm	Wrench	1pc
E		4 x 1-1/4	Wood Screw	8pcs

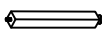
PARTS LIST			
No.	Description	Sketch	Q'ty
1	UPH Headboard		1 PC
2	Bun foot		4 PCS
3	UPH Footboard		1 PC
4	Rails		2 PCS
5	Slat		4 PCS
6	Center Support Leg		8 PCS

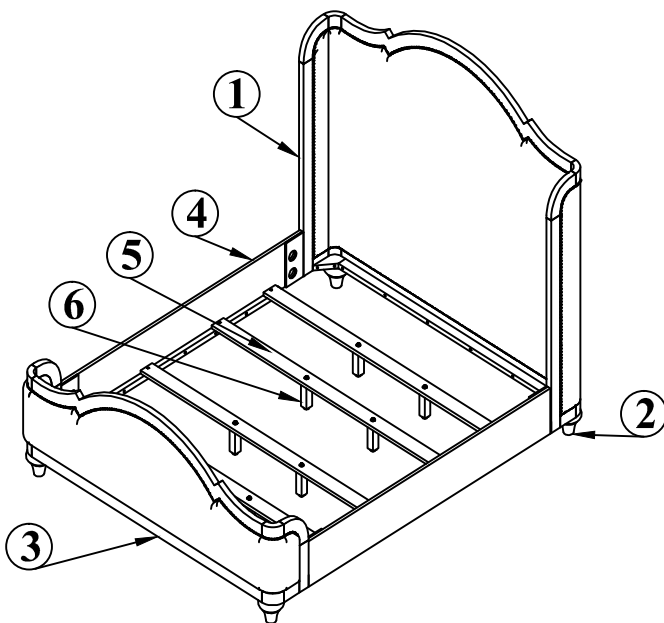

# ASSEMBLY INSTRUCTIONS

**UPH HEADBOARD, 6/6 PLATFORM BED  
RAIL, 5/0, 6/6 PLATFORM BED  
UPH FOOTBOARD, 6/6 PLATFORM BED W/ 4 SLATS**

\*\*\*Caution: Please read all instructions carefully before starting the assembly process. These parts are cumbersome and heavy. Therefore, two people are recommended in order to prevent personal injury and insure the parts are not damaged during the assembly.

## STEP 1:

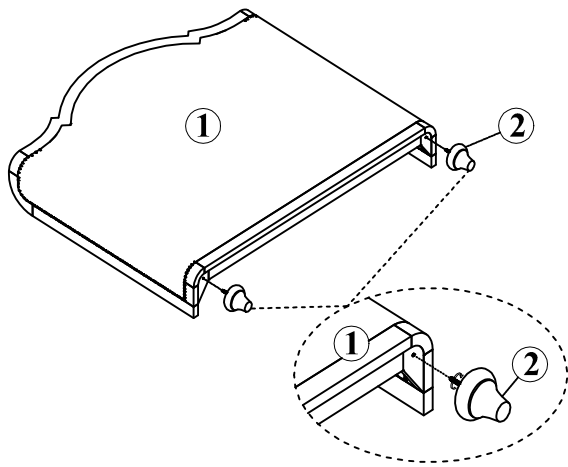

Attach Bun foot (2) to Headboard (1) and Footboard (3).

## STEP 2:

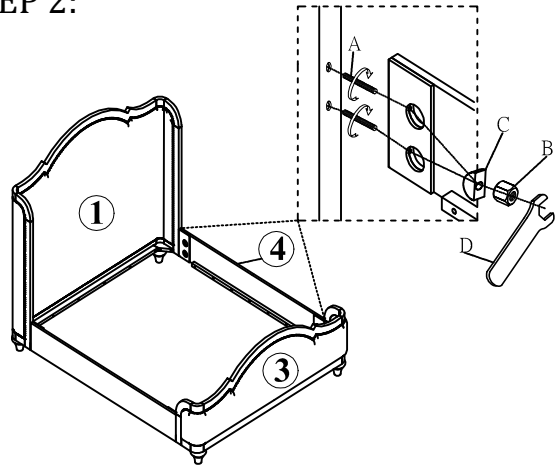

Assemble Side Rails (4) to H/B (1) and F/B (3) by using Thread Bolt (A), Curve washer (C), Hex nut (B) and Wrench (D)

## STEP 3:

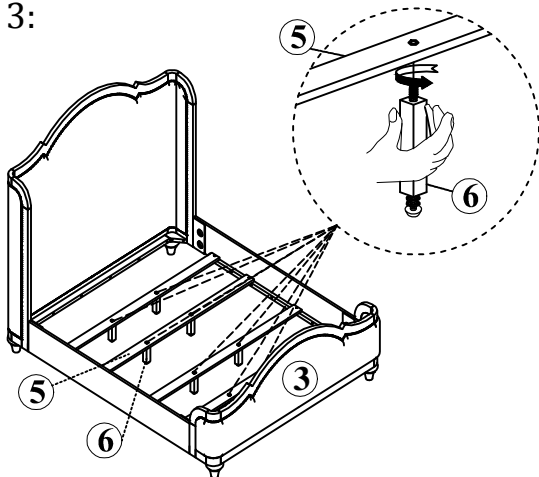

Attach Center Support Leg (6) to Slat (5). Then put slat rolls on middle of bed.

## STEP 4:

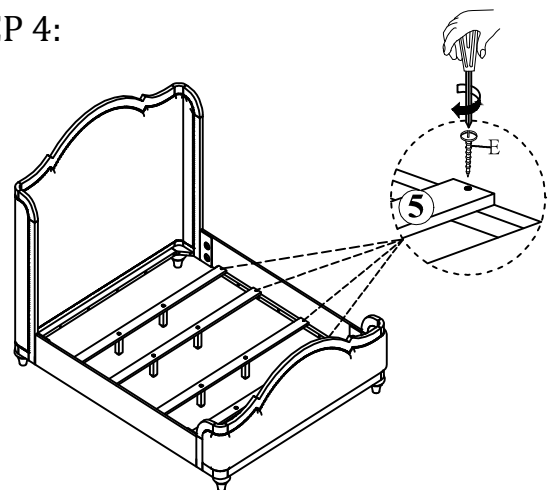

Secure Slats with Screw (E) by screw - driver (not included).

Cleaning instructions: Clean using soft cloth  
Made in Vietnam