

THANK YOU!

For new users simply select the category that applies to the product you've purchased and fill out the product registration form. Once the registration process is complete you will be able to:

- Register one or multiple products
- Order parts
- Download user manuals
- Request product information or assistance

If you are unable to register your product, please save your proof of purchase for part replacement purposes.

IMPORTANT:
Retain for future reference.
Read carefully.

MERCI!

Pour les nouveaux utilisateurs, sélectionnez simplement la catégorie qui s'applique au produit que vous avez acheté et remplissez le formulaire d'enregistrement du produit. Une fois le processus d'enregistrement complété, vous serez en mesure de:

- Enregistrer un ou plusieurs produits
- Commander des pièces
- Télécharger le manuel de l'utilisateur
- Demander de l'information ou de l'assistance sur le produit

Si vous ne parvenez pas à enregistrer votre produit, s'il vous plaît gardez votre reçu comme preuve d'achat pour tout remplacement de pièces.

IMPORTANT:
Conserver pour référence future. Lisez correctement

GRACIAS!

Para los usuarios nuevos, simplemente seleccione la categoría que se aplica al producto que ha comprado y llene el formulario de registro del producto. Una vez finalizado el proceso de registro, usted podrá:

- Registrar uno o varios productos
- Realizar pedidos de piezas
- Descargar manuales de usuario
- Solicitar información o asistencia sobre el producto

Si usted no puede registrar su producto, por favor guarde el comprobante de compra para el propósito de reponer piezas.

IMPORTANTE:
Conservar para futuras consultas. Lea cuidadosamente.

**DEPENDABLE
CUSTOMER
SERVICE**



NO NEED TO RETURN
TO STORE!



Please have your store receipt, instruction manual, and part number ready when you call.

**UN SERVICE À
LA CLIENTÈLE
FIABLE**



UN SERVICE À LA
CLIENTÈLE FIABLE!



Veillez avoir en main, avant de nous contacter, la facture de votre marchand, votre manuel d'instruction et le numéro de pièce requise.

**SERVICIO
DE ATENCIÓN
AL CLIENTE
FIABLE**



NO ES NECESARIO
DEVOLVERLO A LA TIENDA!



Tenga a la mano su recibo de la tienda, el manual de instrucciones, y el número de la pieza cuando realice la llamada.

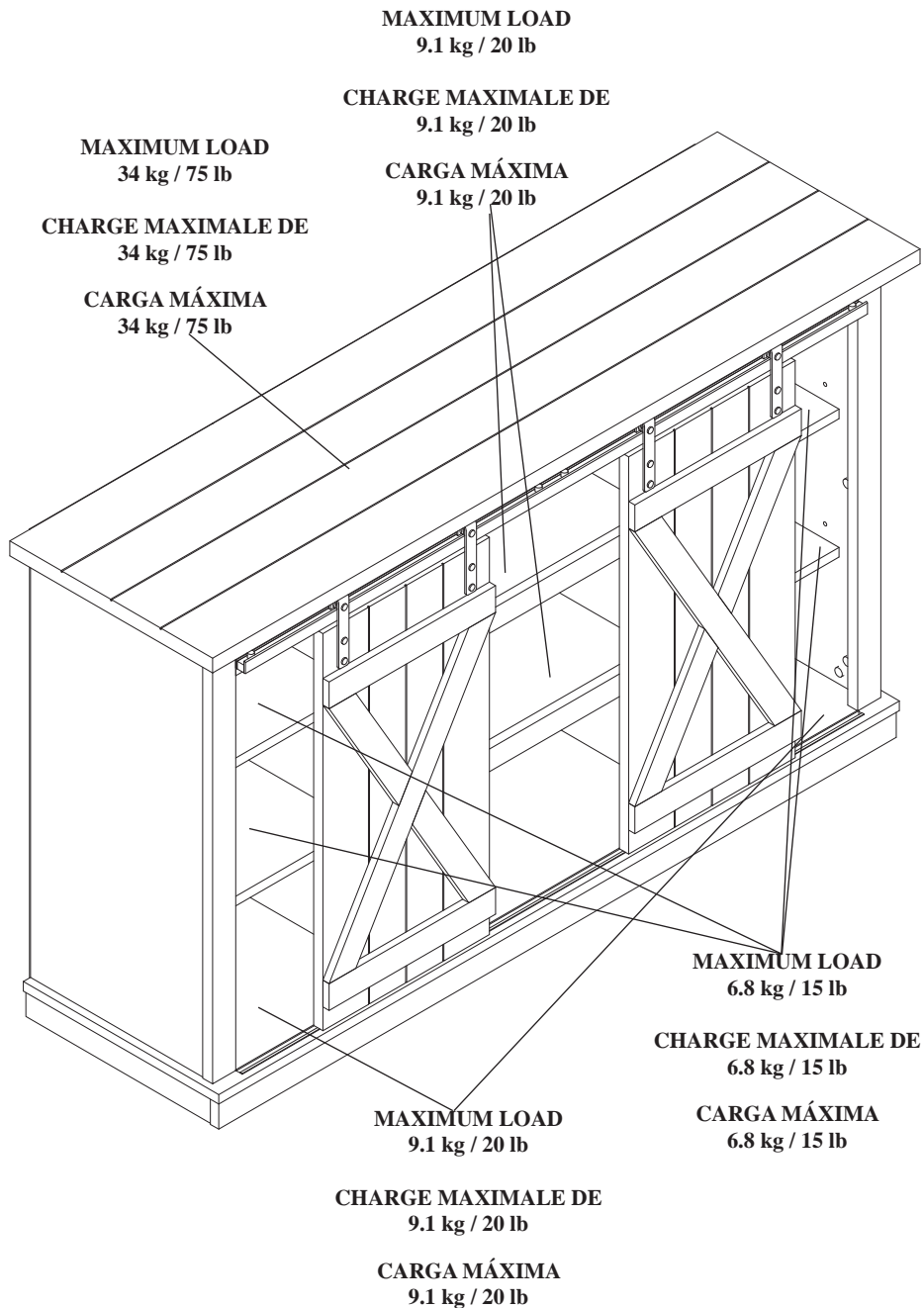

WARNING:

For use with most LCD/Plasma televisions weighing 34 kg / 75 lb or less. Use with televisions or loads heavier than the maximum weights specified may result in instability causing tip over resulting in death or serious injury.

ATTENTION:

Destiné à la plupart des téléviseurs à écran LCD/Plasma pesant 34 kg / 75 lb ou moins. Toute installation en vue de supporter des téléviseurs ou des charges d'un poids supérieur aux valeurs indiquées peut déboucher sur une instabilité provoquant un basculement pouvant entraîner la mort ou un accident grave.

PRECAUCIÓN:

Para usar con la mayoría de televisiones de LCD / Plasma, con peso de 34 kg / 75 lb o inferior. Utilizar con televisores o cargas más pesadas que los pesos máximos especificados puede dar lugar a inestabilidad que produzca un vuelco que tenga como resultado muerte o lesiones graves.

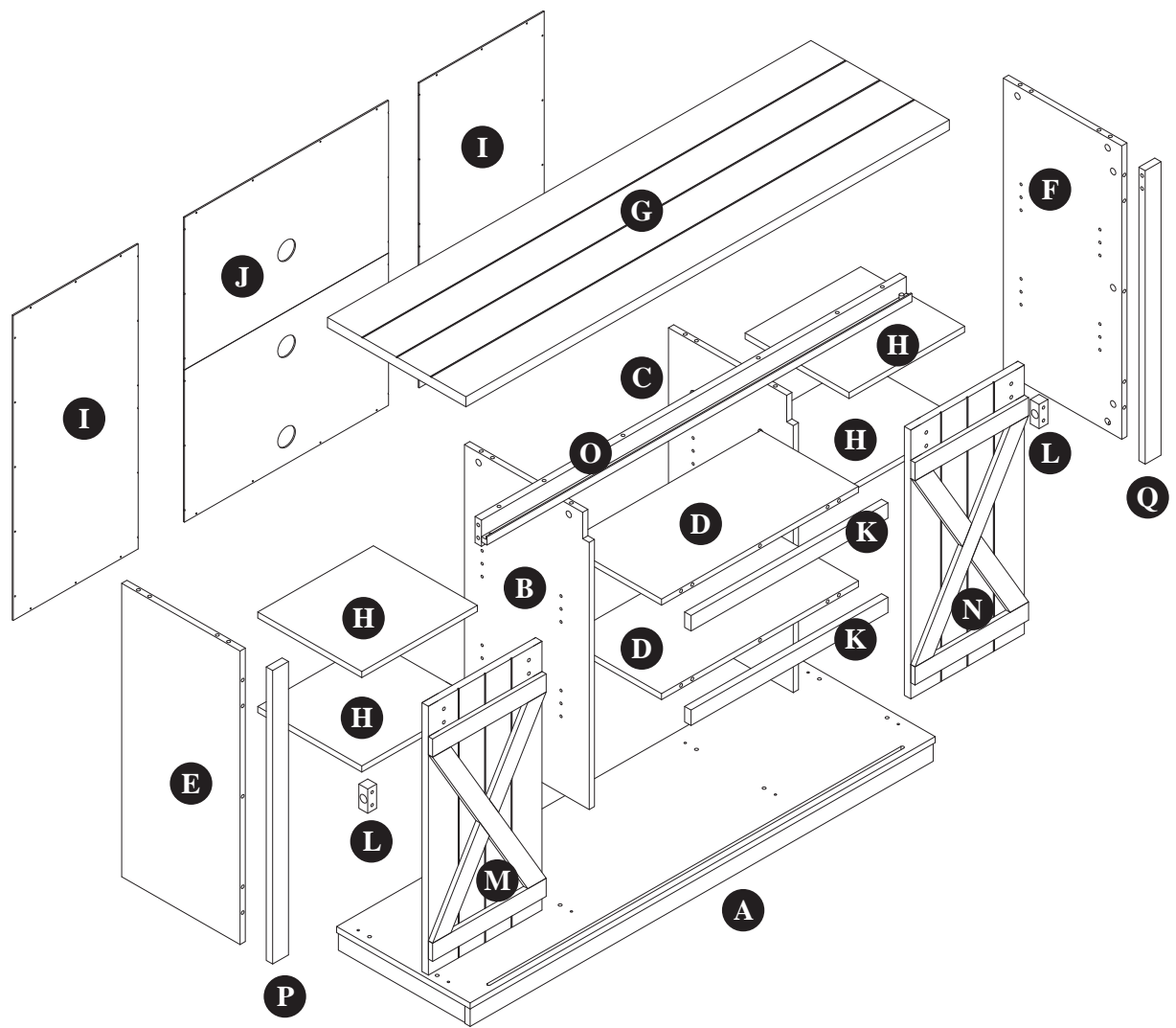

SAFETY INFORMATION

INFORMATION DE SÉCURITÉ

INFORMACIÓN DE SEGURIDAD



Please read and understand this entire manual before attempting to assemble, operate or install the product.



WARNING

- Some steps are more easily handled with two adults.

CAUTION

- Before assembly and/or installation, carefully unwrap all parts.
- Locate and set aside the hardware kit before discarding packaging.
- Use care when assembling your new product. Take your time and follow the assembly instructions closely.



Assurez-vous de lire et de comprendre l'intégralité du présent manuel avant de tenter d'assembler, d'utiliser ou d'installer le produit.



AVERTISSEMENT

- Certaines étapes sont plus faciles à effectuer avec l'aide

MISE EN GARDE

- Avant l'assemblage et/ou l'installation, vous devez déballer minutieusement toutes les pièces.
- Localisez et mettez de côté le jeu de quincaillerie avant de jeter l'emballage.
- Soyez vigilant lorsque vous assemblez le nouveau produit. Prenez votre temps et suivez attentivement ces instructions.



Lea y comprenda completamente este manual antes de intentar ensamblar, usar o instalar el producto.



ADVERTENCIA

- Algunos de los pasos se pueden realizar con mayor facilidad entre dos adultos.

PRECAUCIÓN

- Antes del ensamblaje y/o instalación, desenvuelva cuidadosamente todas las piezas.
- Localice y separe el equipo de accesorios antes de desechar el embalaje.
- Tenga cuidado al ensamblar el nuevo producto. Tómese su tiempo y siga detenidamente las instrucciones de ensamblaje.

TOOLS REQUIRED OUTILS NÉCESSAIRES HERRAMIENTAS NECESARIAS

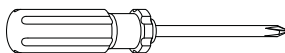

(NOT INCLUDED)
(PAS INCLUS)
(NO INCLUIDAS)

HARDWARE/QUINCAILLERIE/FERRETERÍA

[x28]

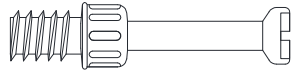

AA

[x28]



BB

[x28]



Ø8x30mm

CC

[x4]

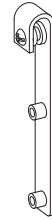

DD

[x8]

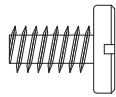

Ø6.3x12mm

EE

[x42]

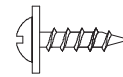

Ø3x12mm

FF

[x4]



GG

[x8]

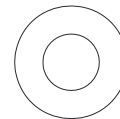

Ø15mm

HH

HARDWARE/QUINCAILLERIE/FERRETERÍA

[x2]

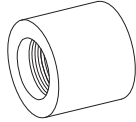

II

[x2]

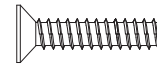

JJ

Ø4x19mm

[x4]

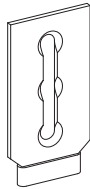

KK

[x12]

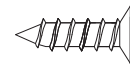

LL

Ø4x15mm

[x4]

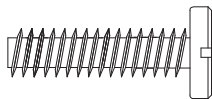

MM

Ø6.3x25mm

[x24]

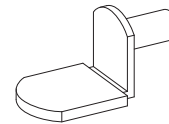

NN

[x2]

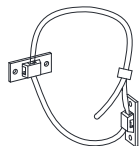

OO

[x1]



ZZ

Touch-Up pen

1

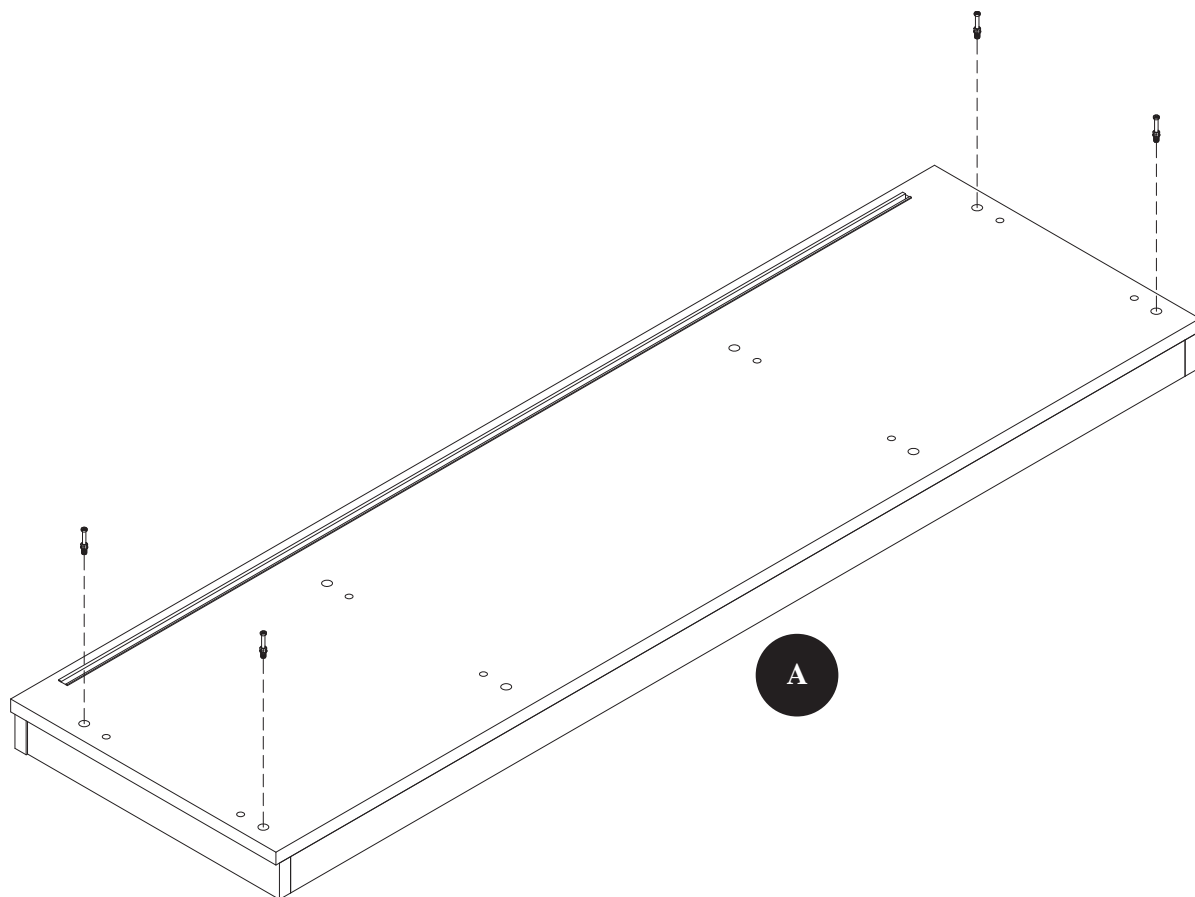

AA

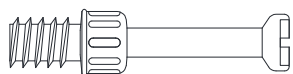

[x4]

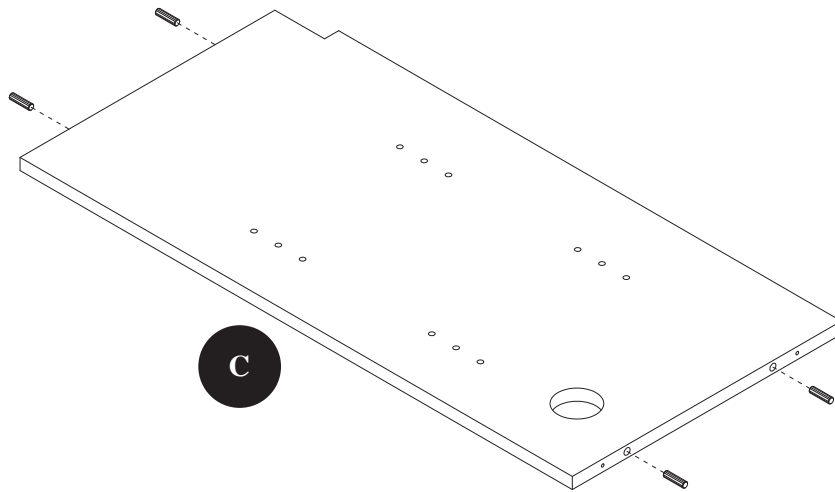
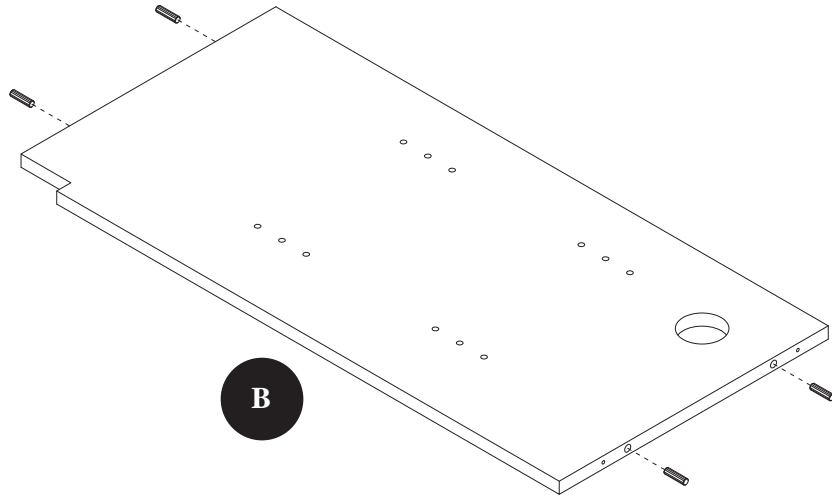

CC



[x8]

3

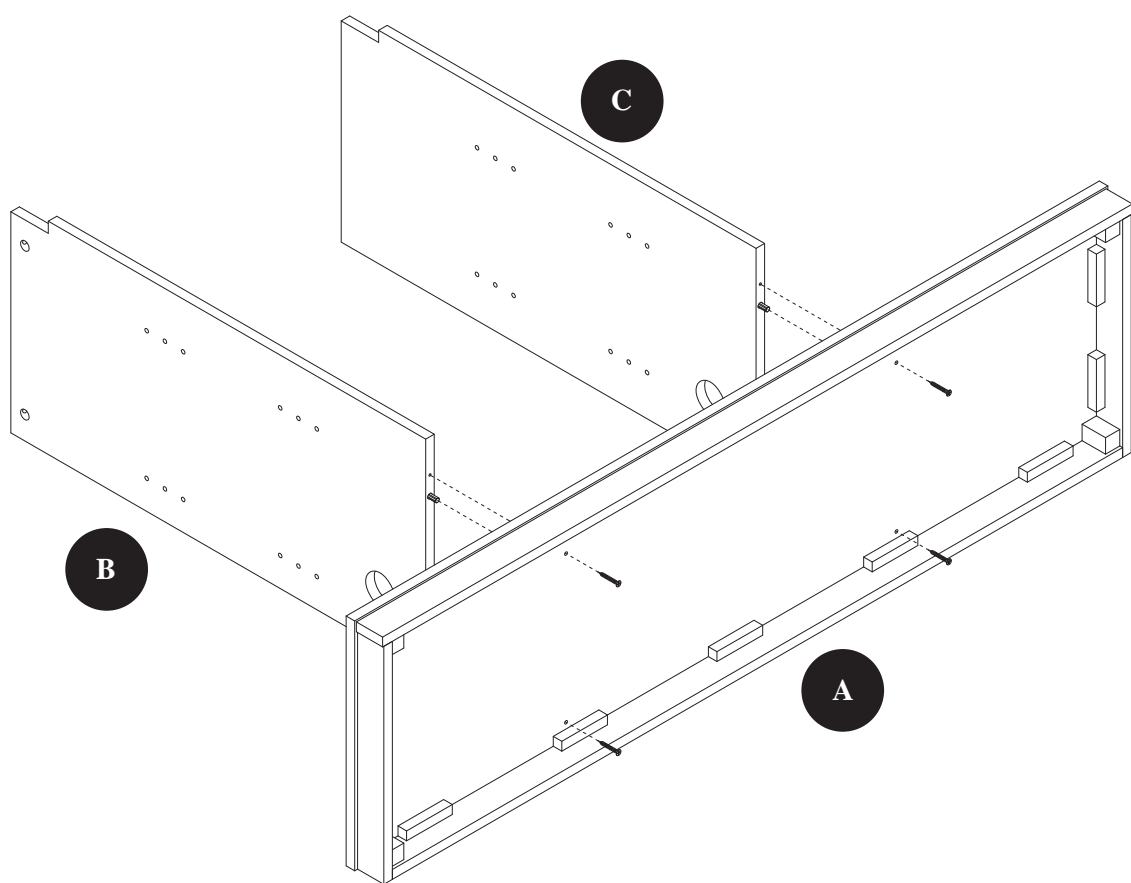

GG



[x4]

4

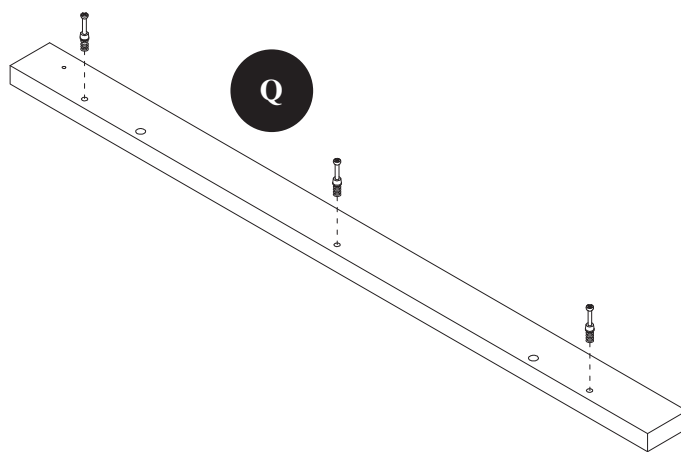
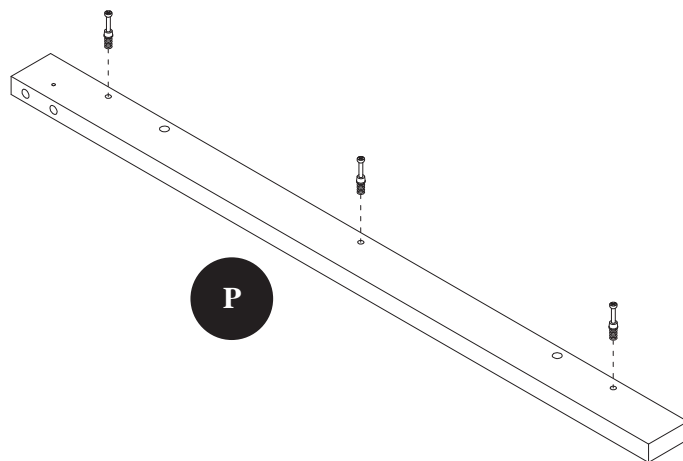

AA

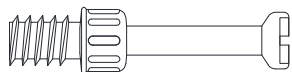

[x6]

5

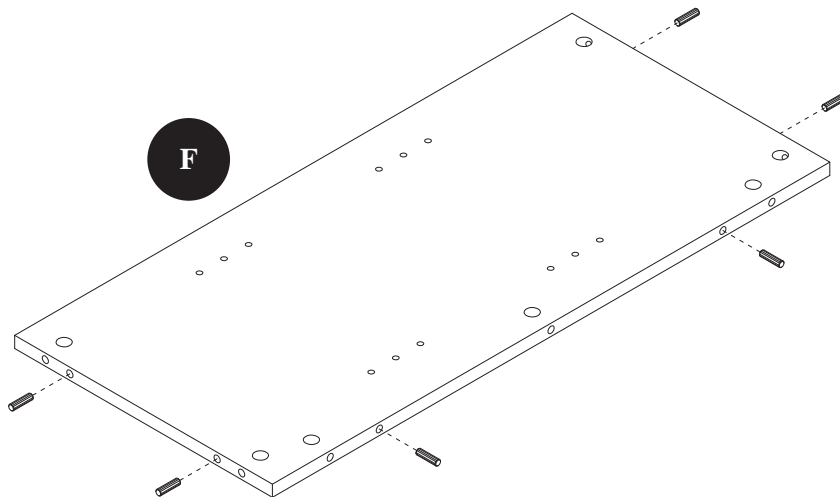
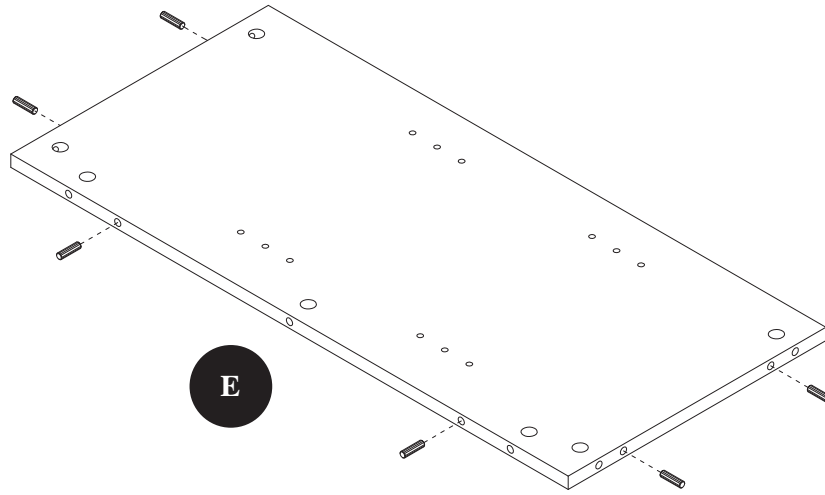

CC



[x12]

6

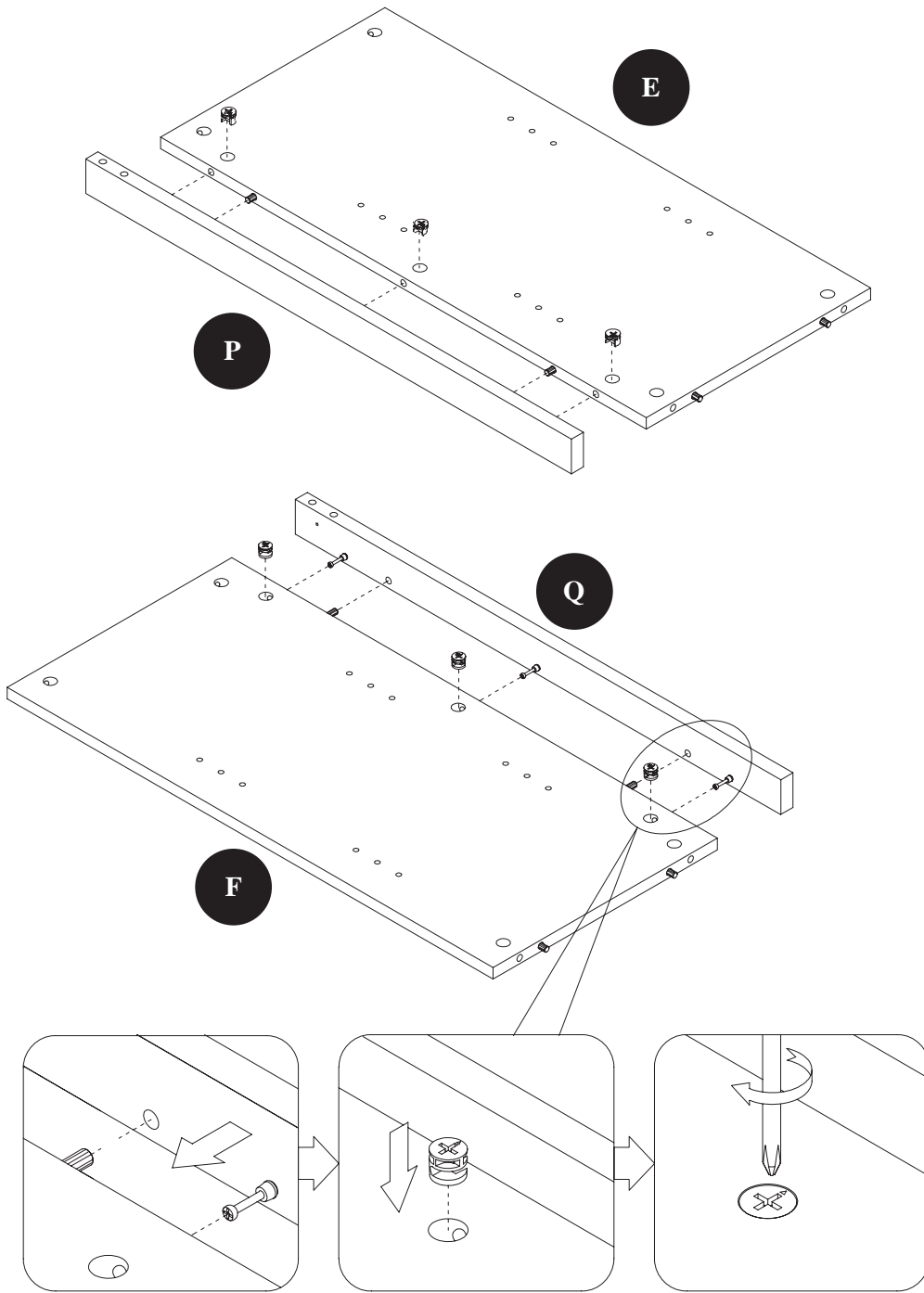

BB



[x6]

7

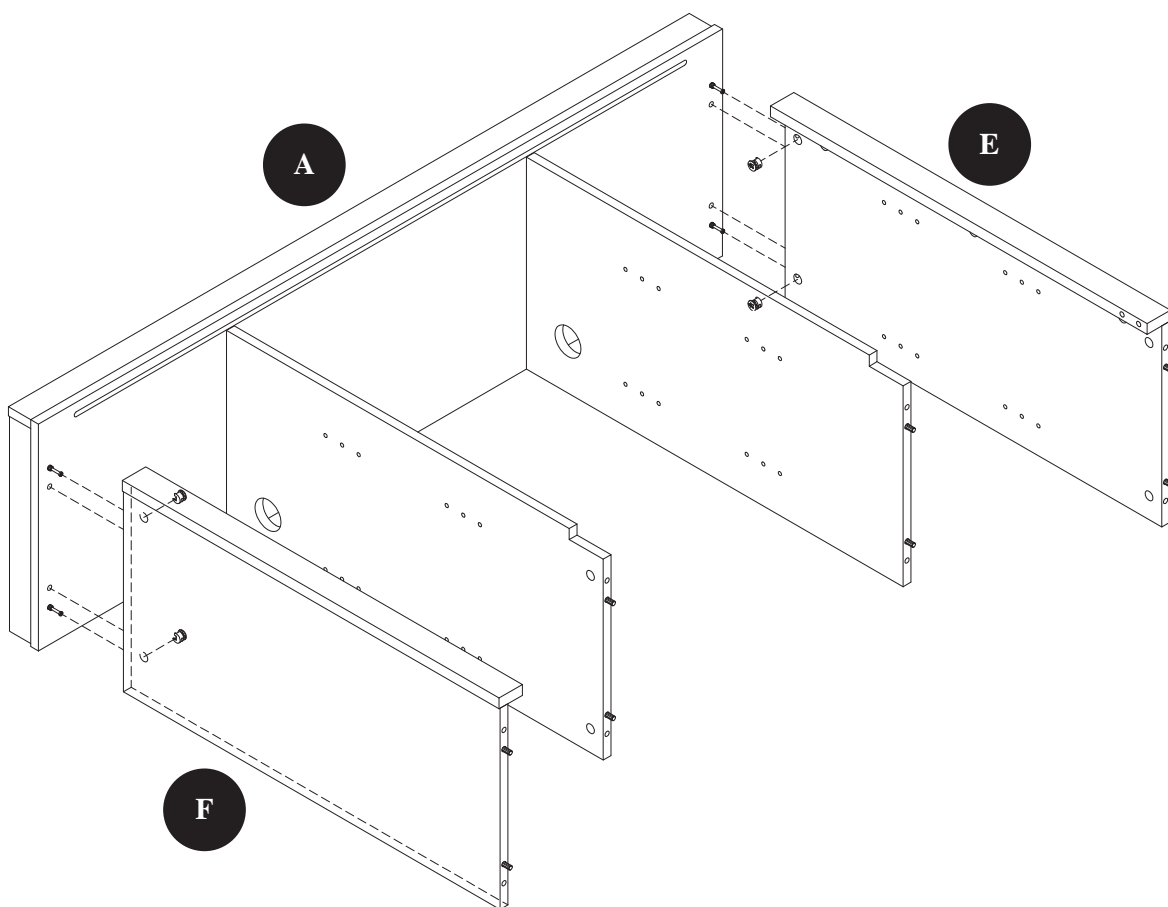
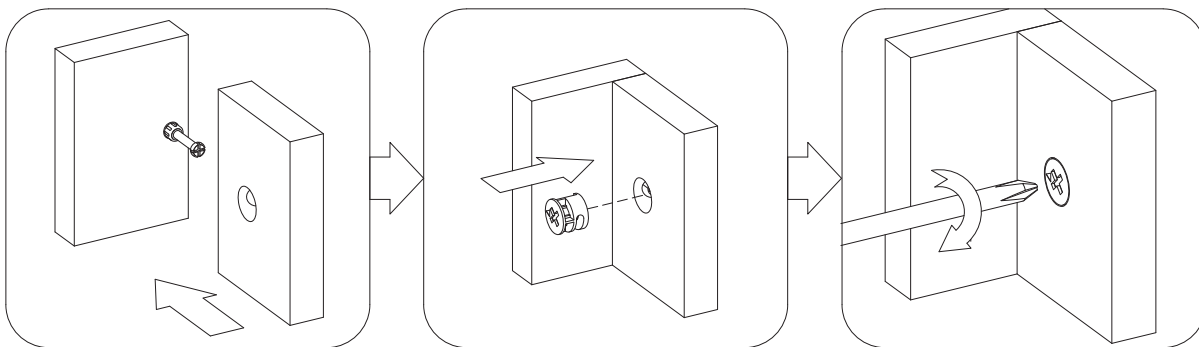

BB



[x4]

8

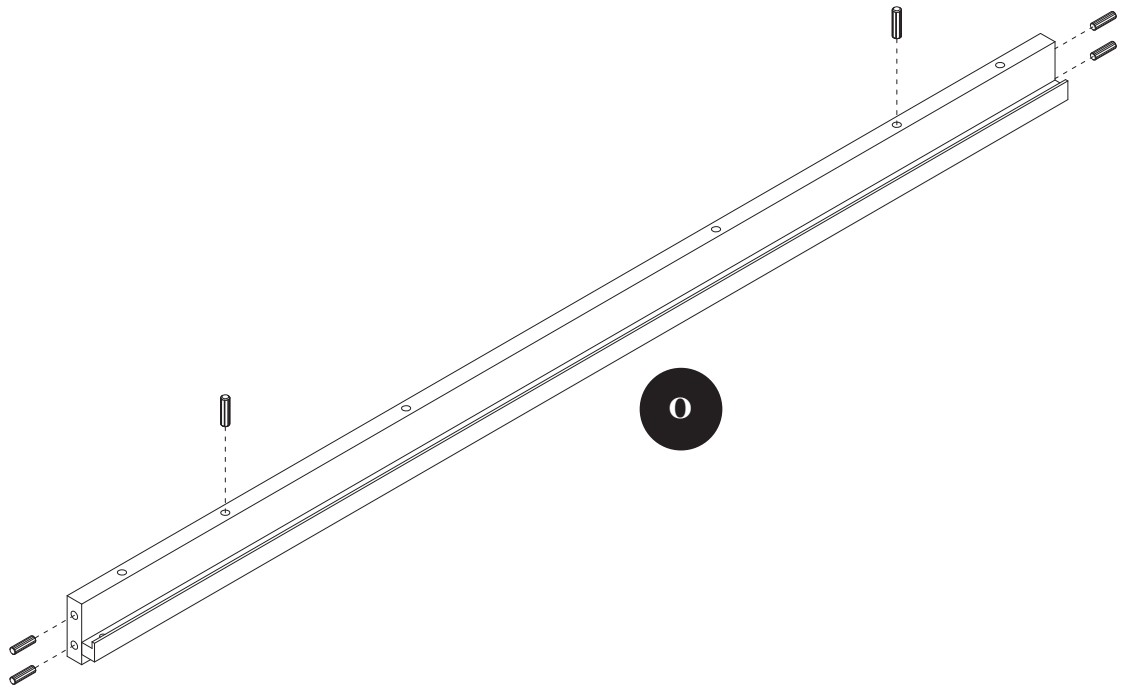

CC



[x6]

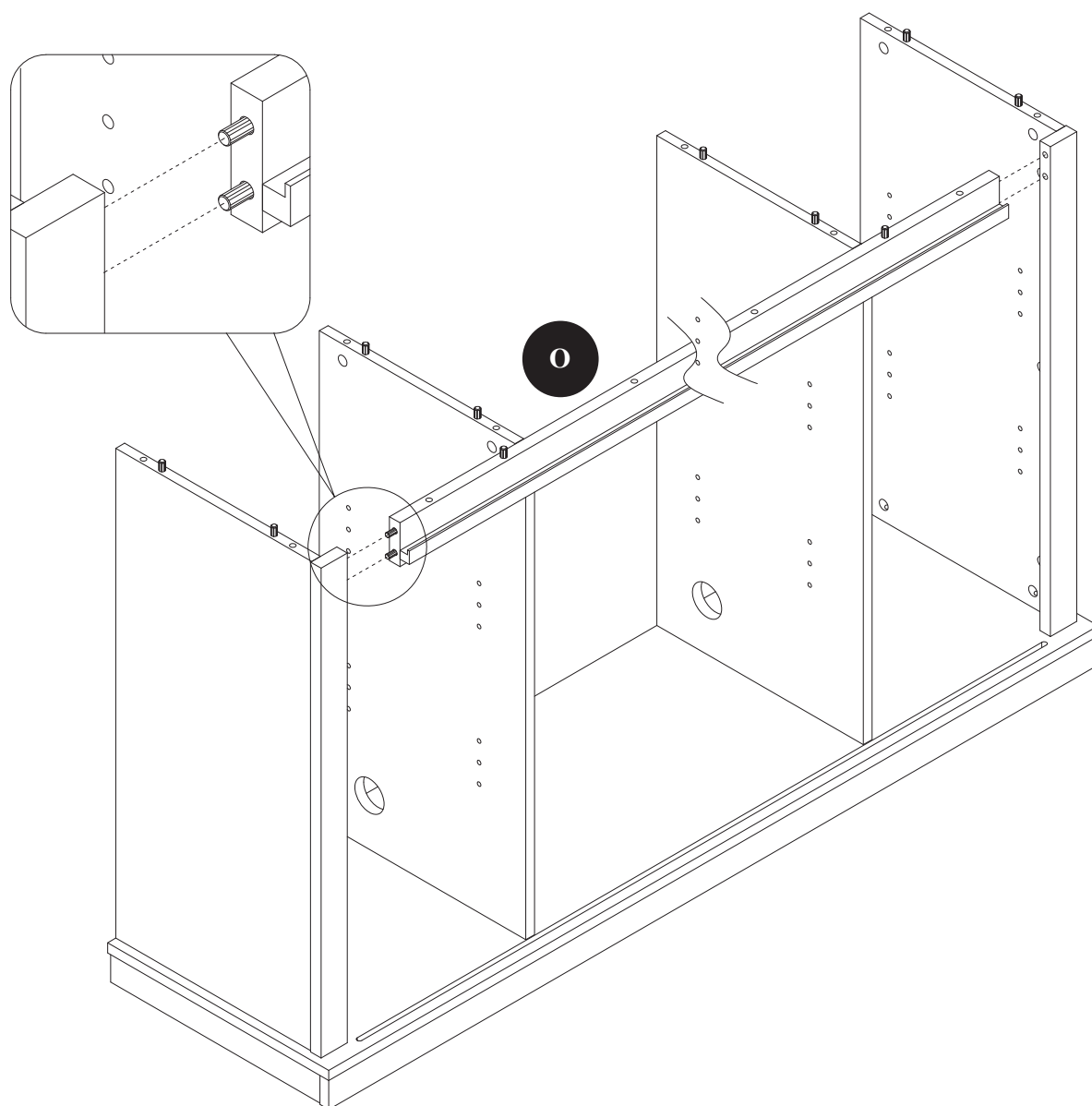

10

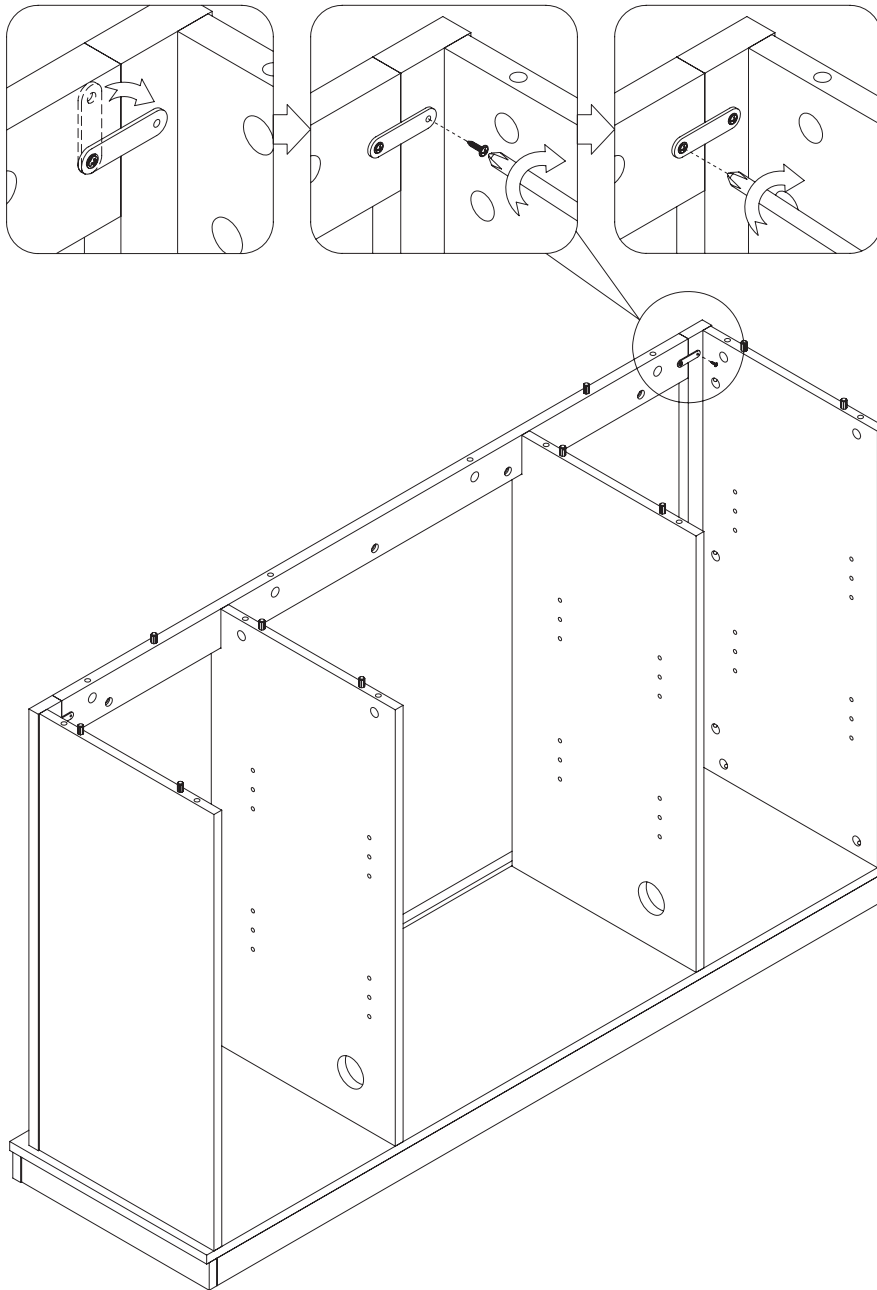

FF

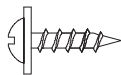

[x2]

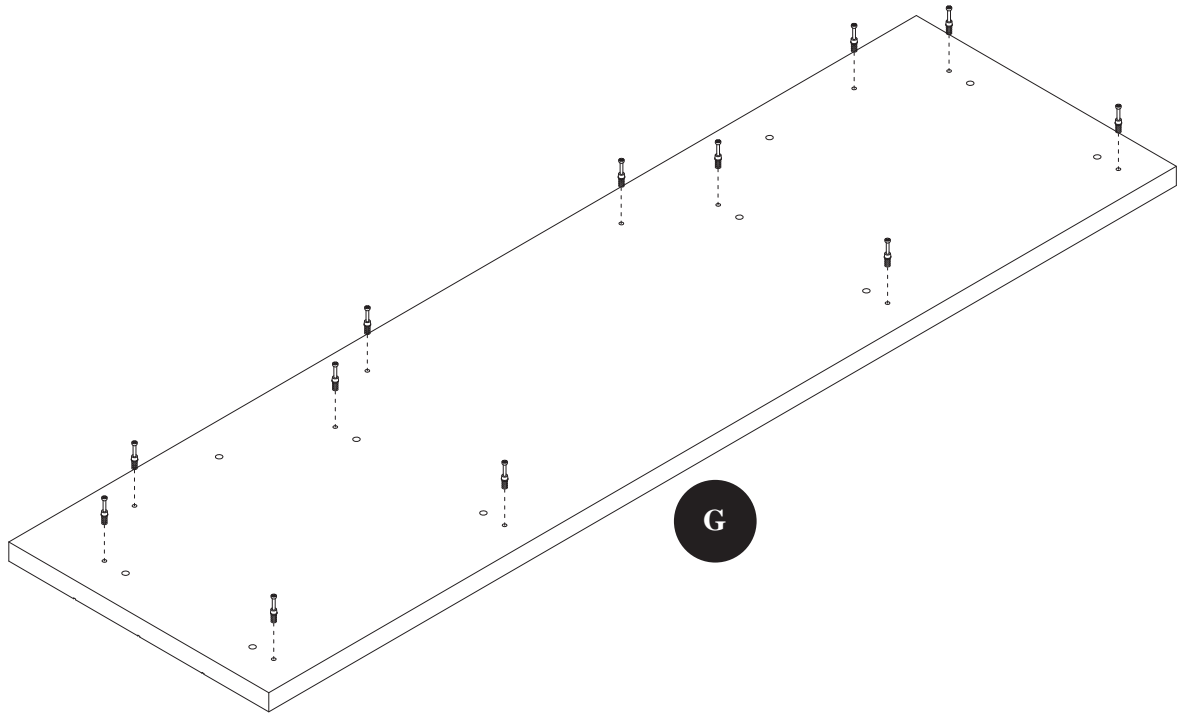

AA

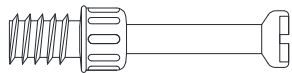

[x12]

12

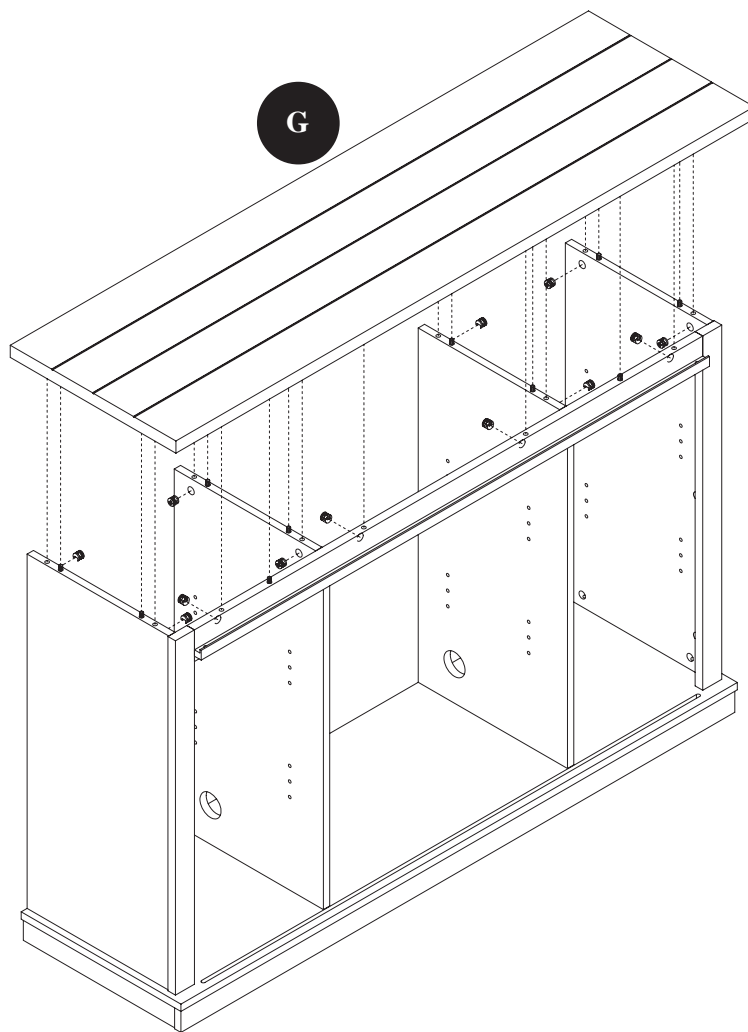
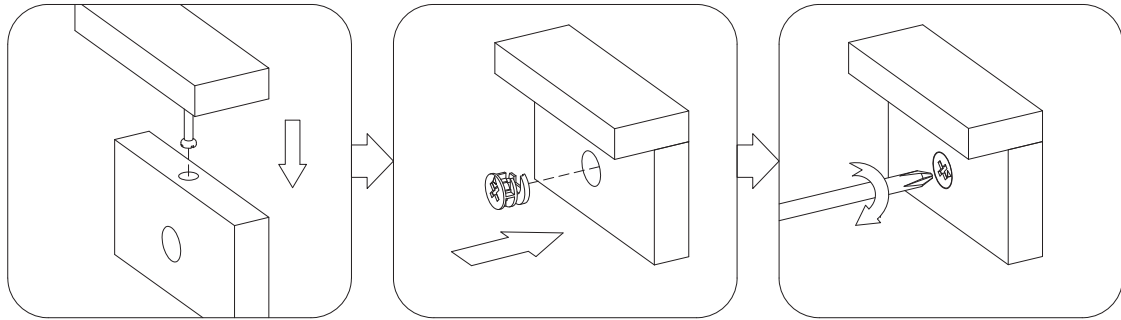

BB



[x12]

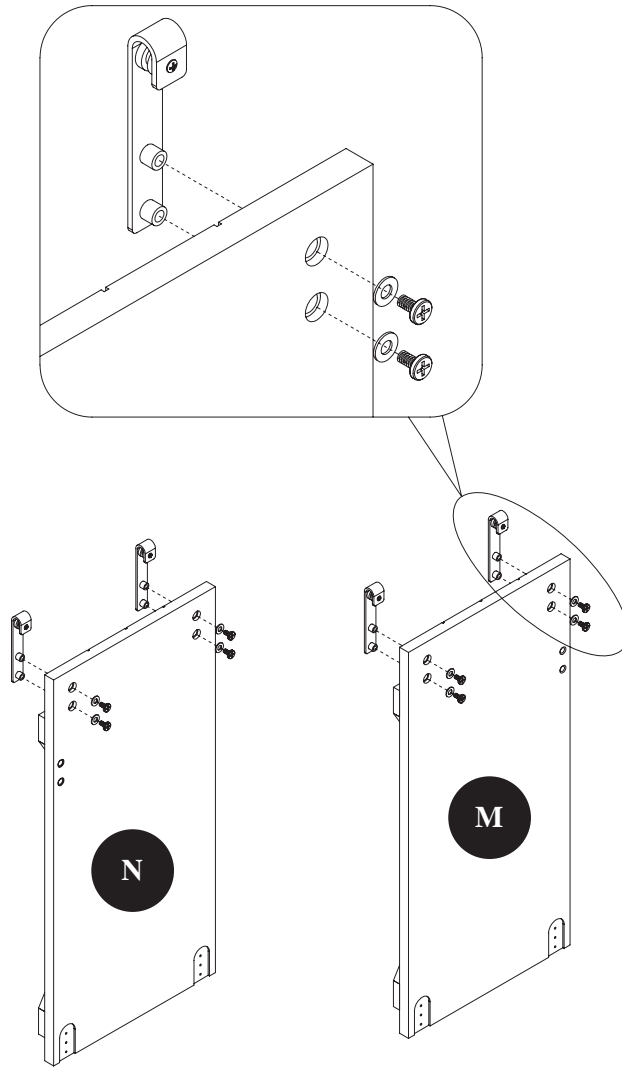

DD

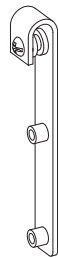

[x4]

EE

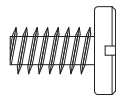

[x8]

HH

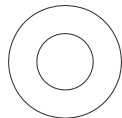

[x8]

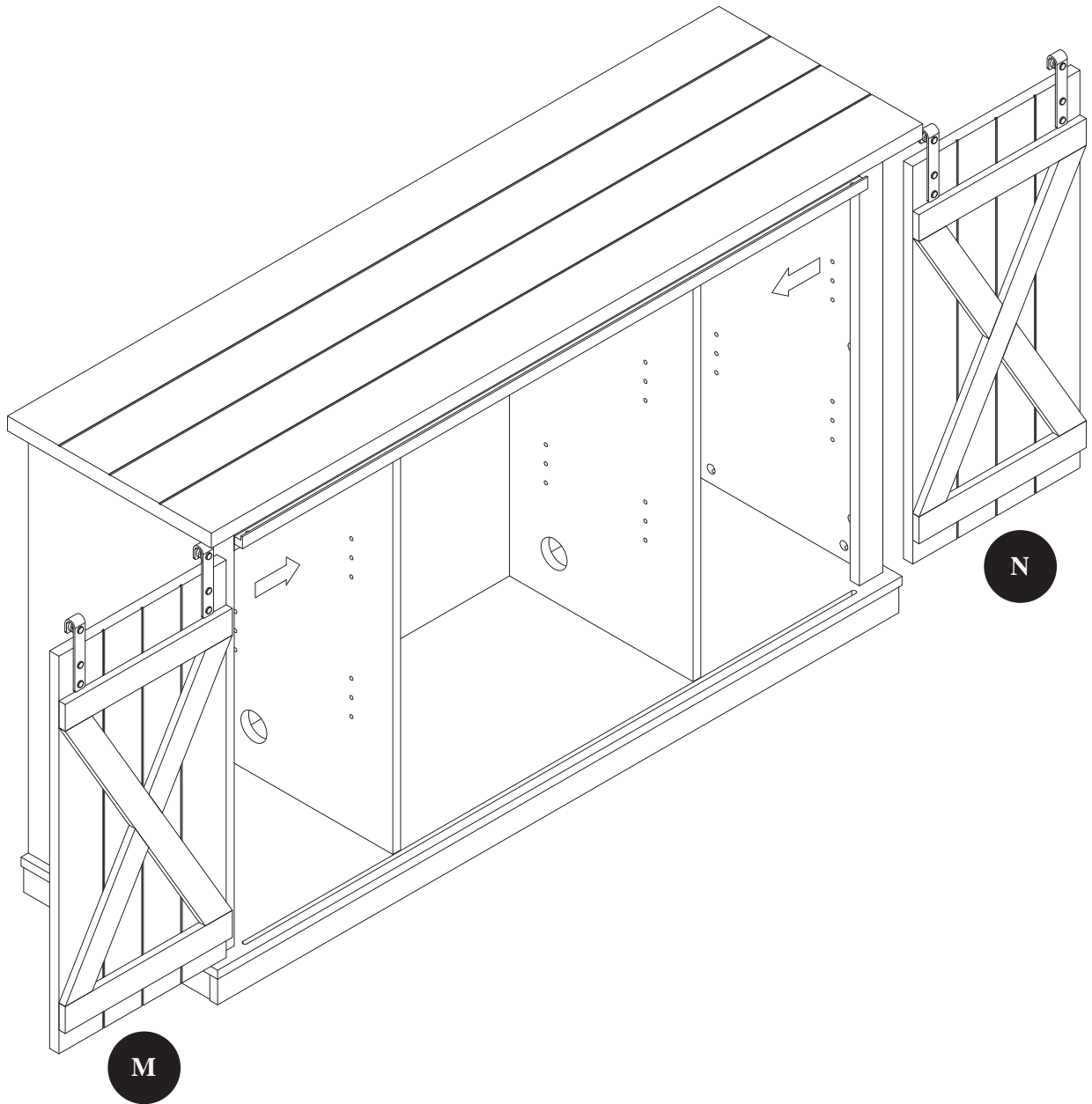

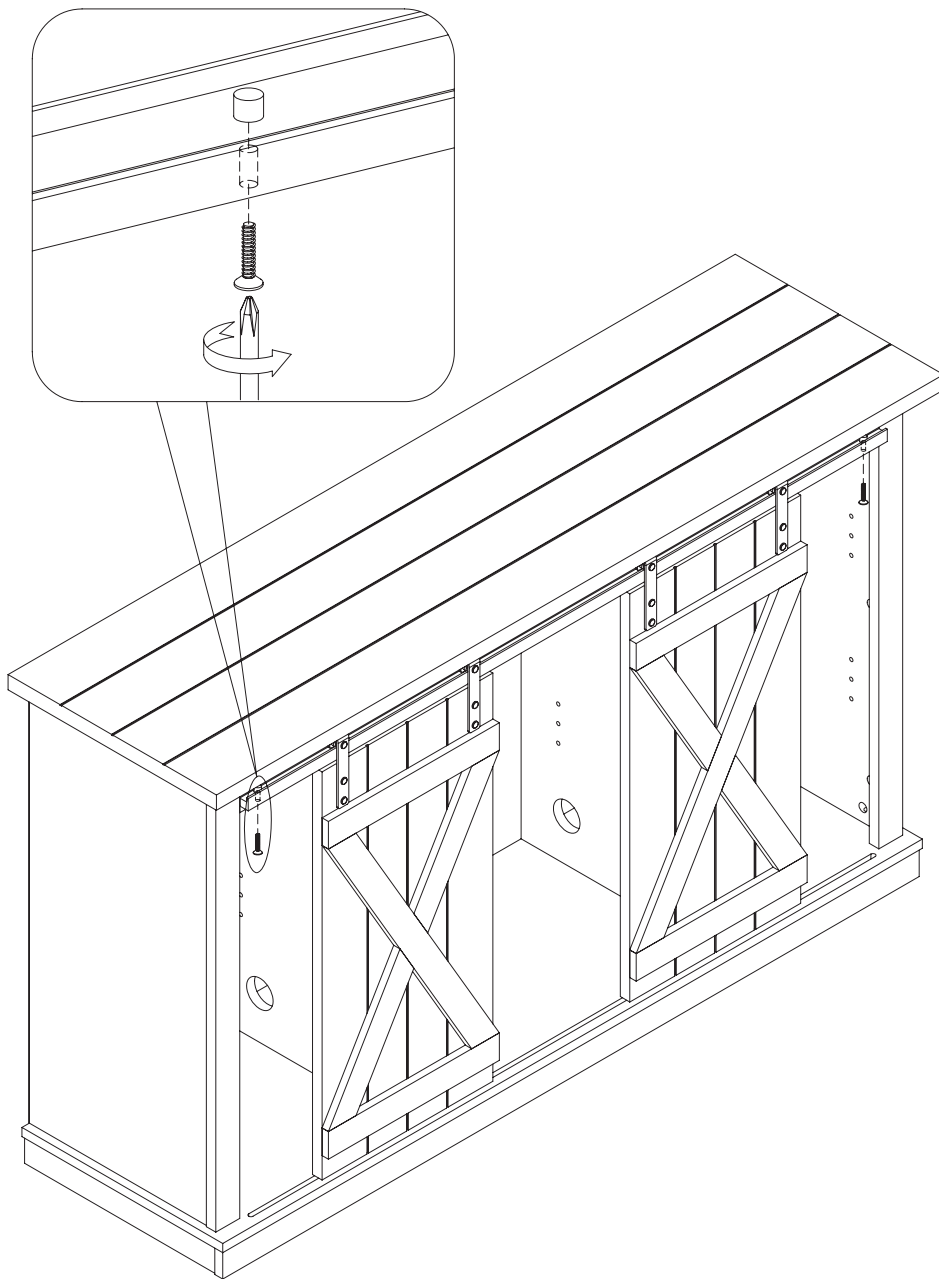

II

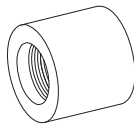

[x2]

JJ

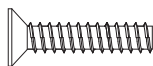

[x2]

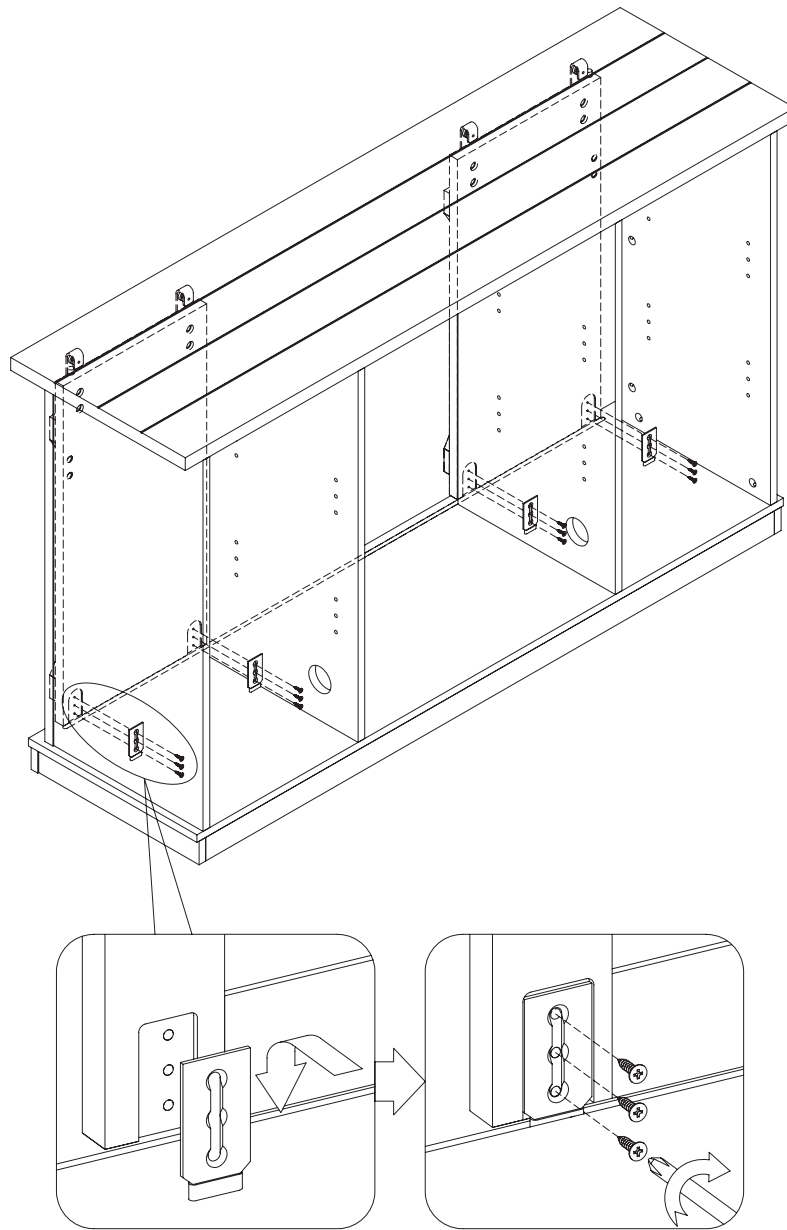

KK

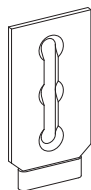

[x4]

LL

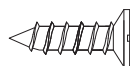

[x12]

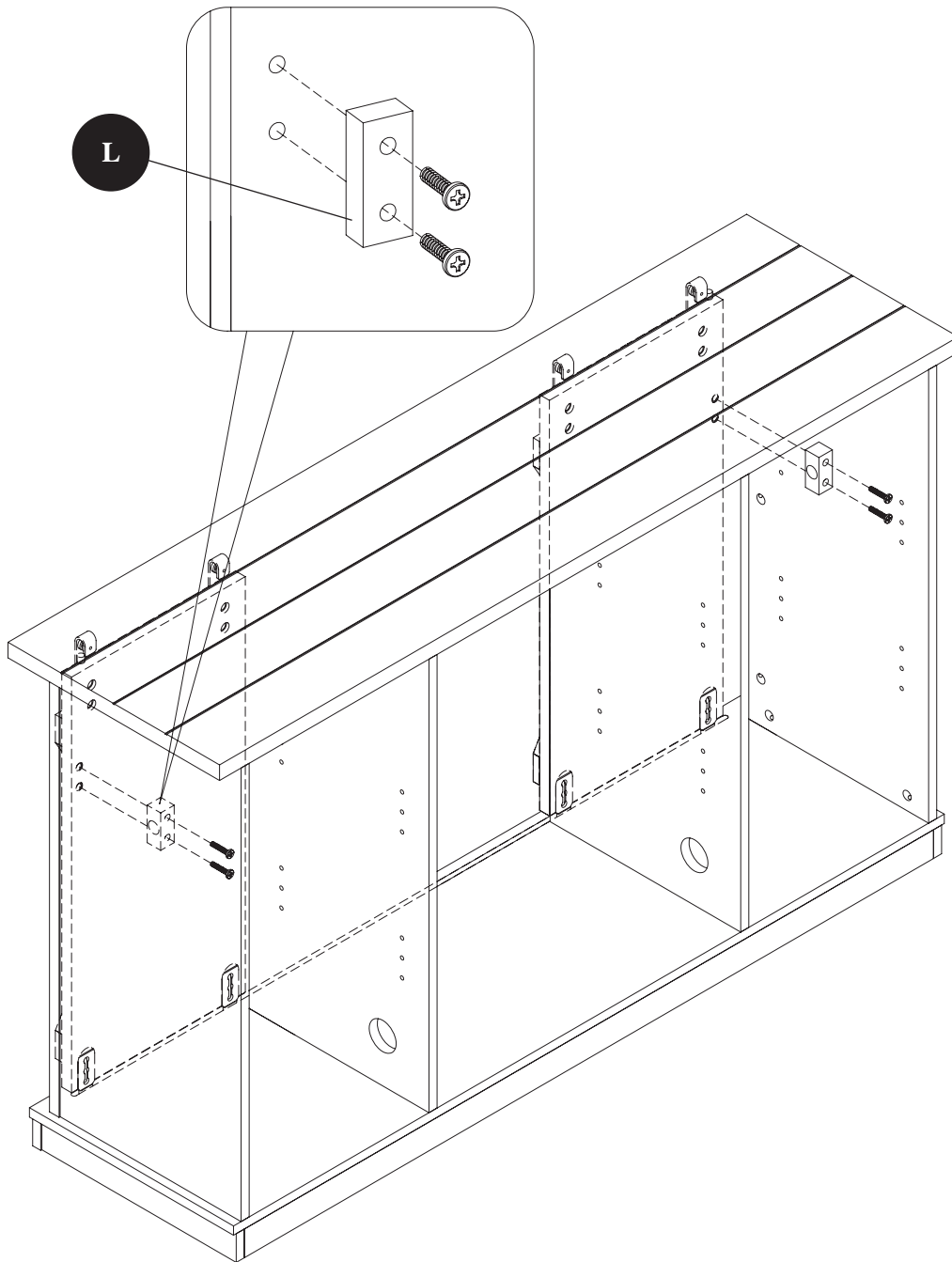

MM

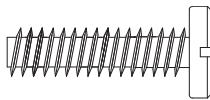

[x4]

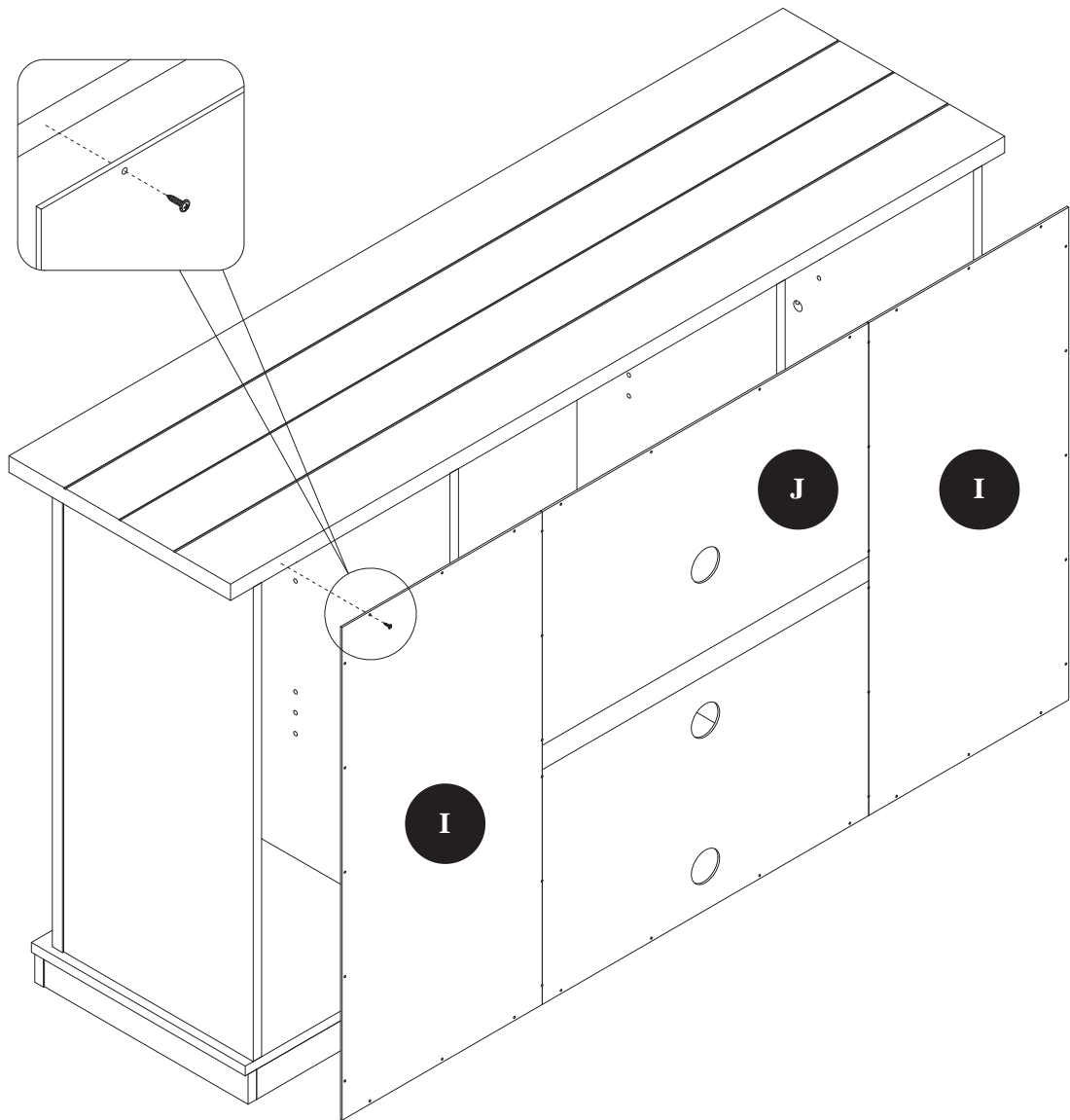

FF

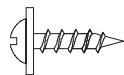

[x40]

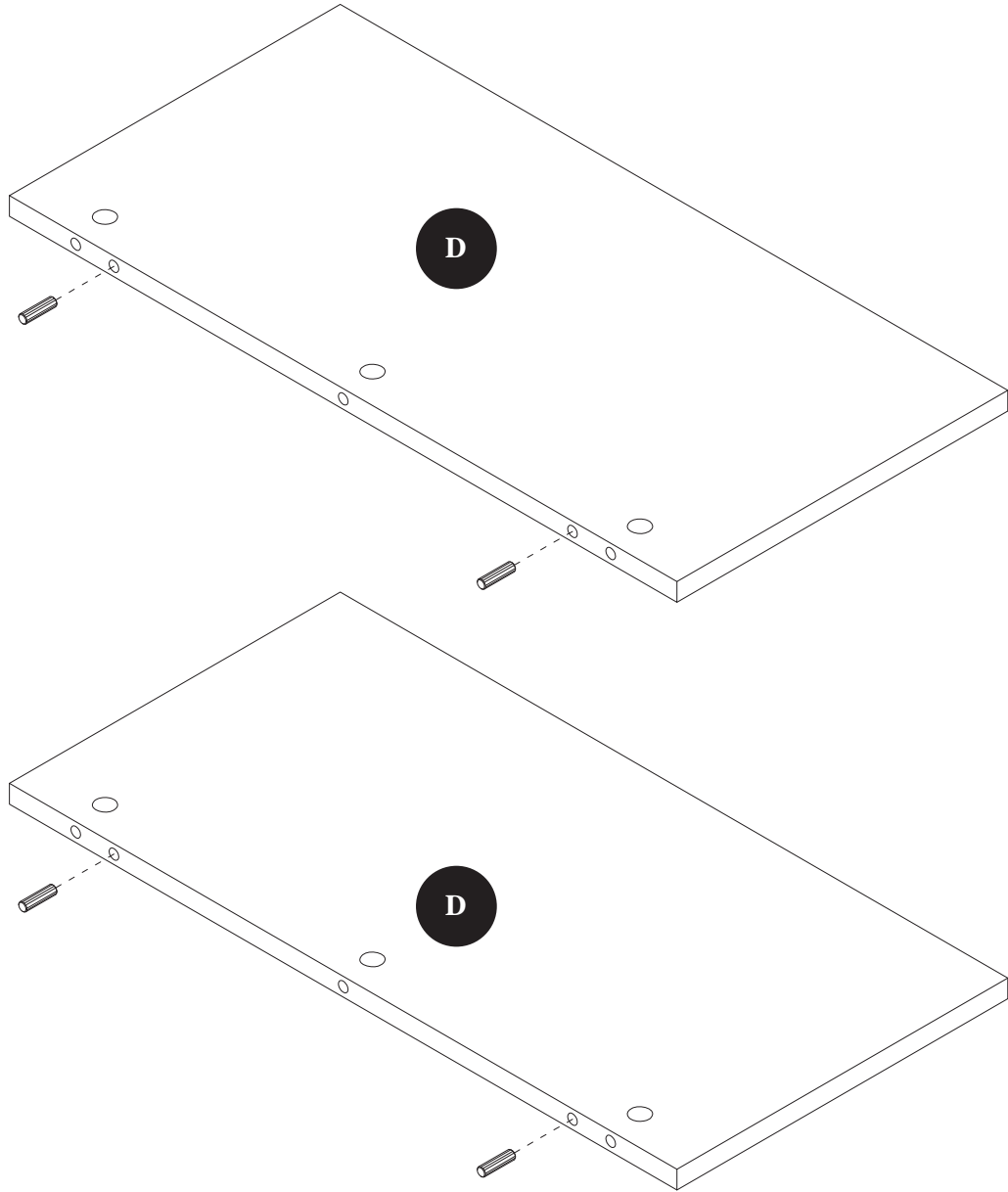

CC



[x4]

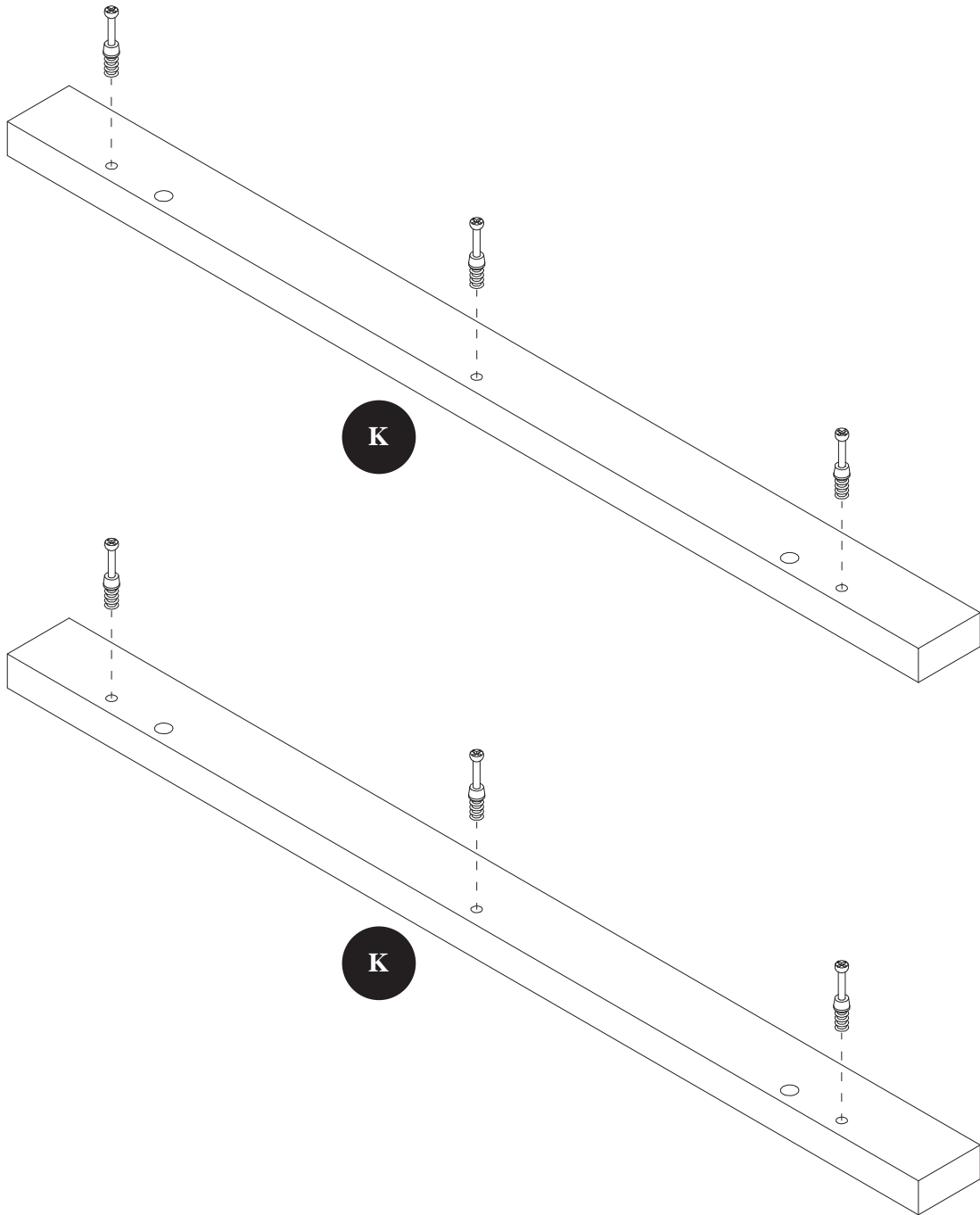

AA

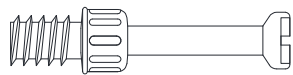

[x6]

21

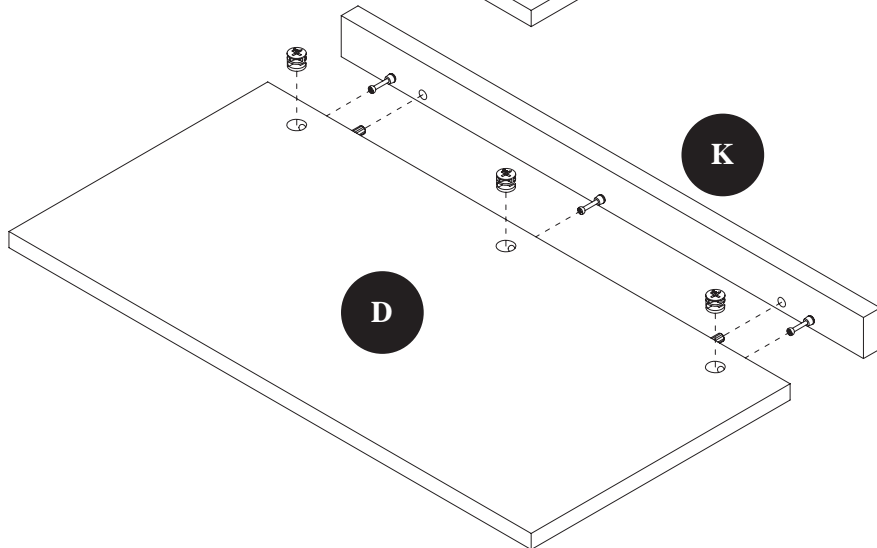
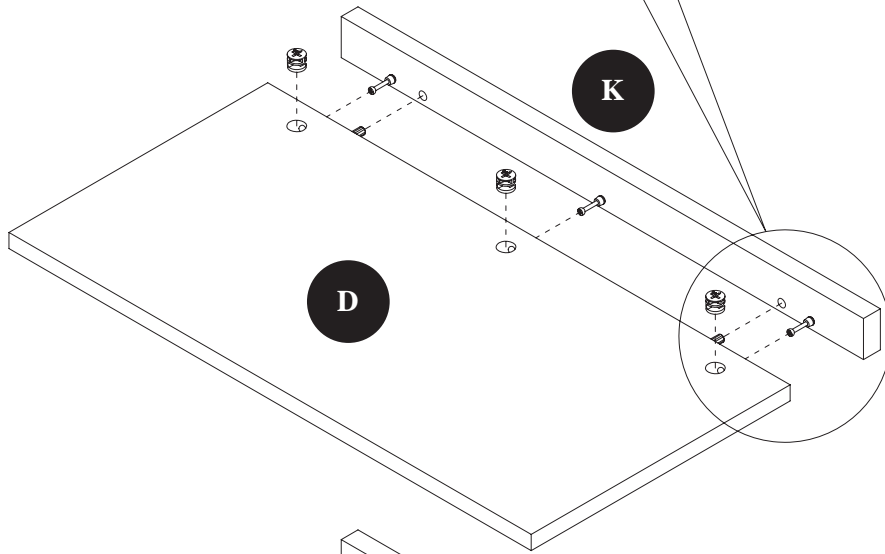
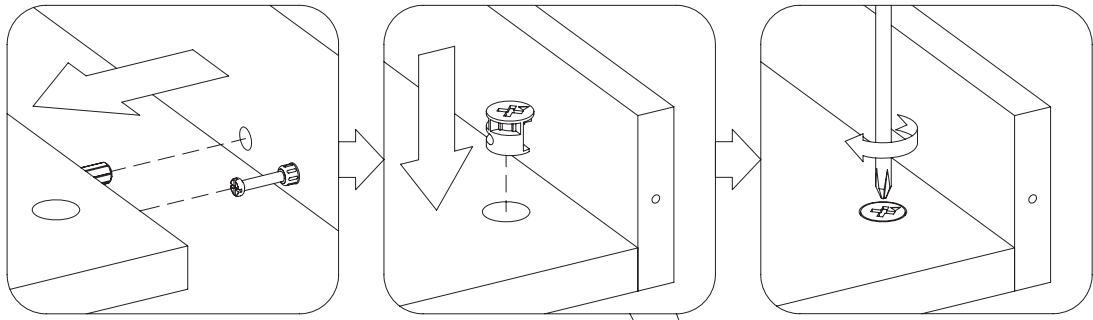

BB



[x6]

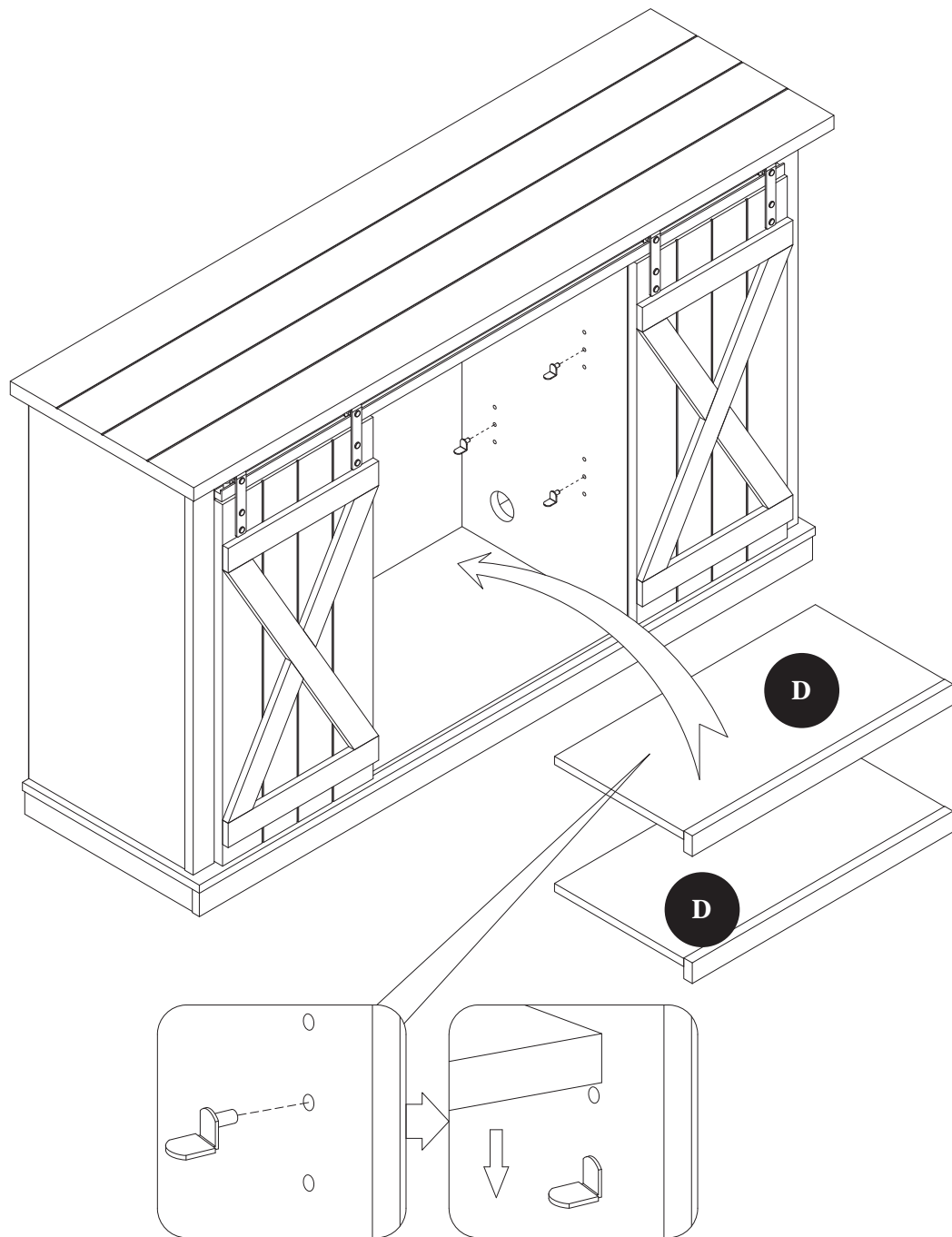

NN

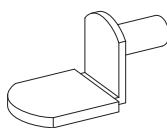

[x8]

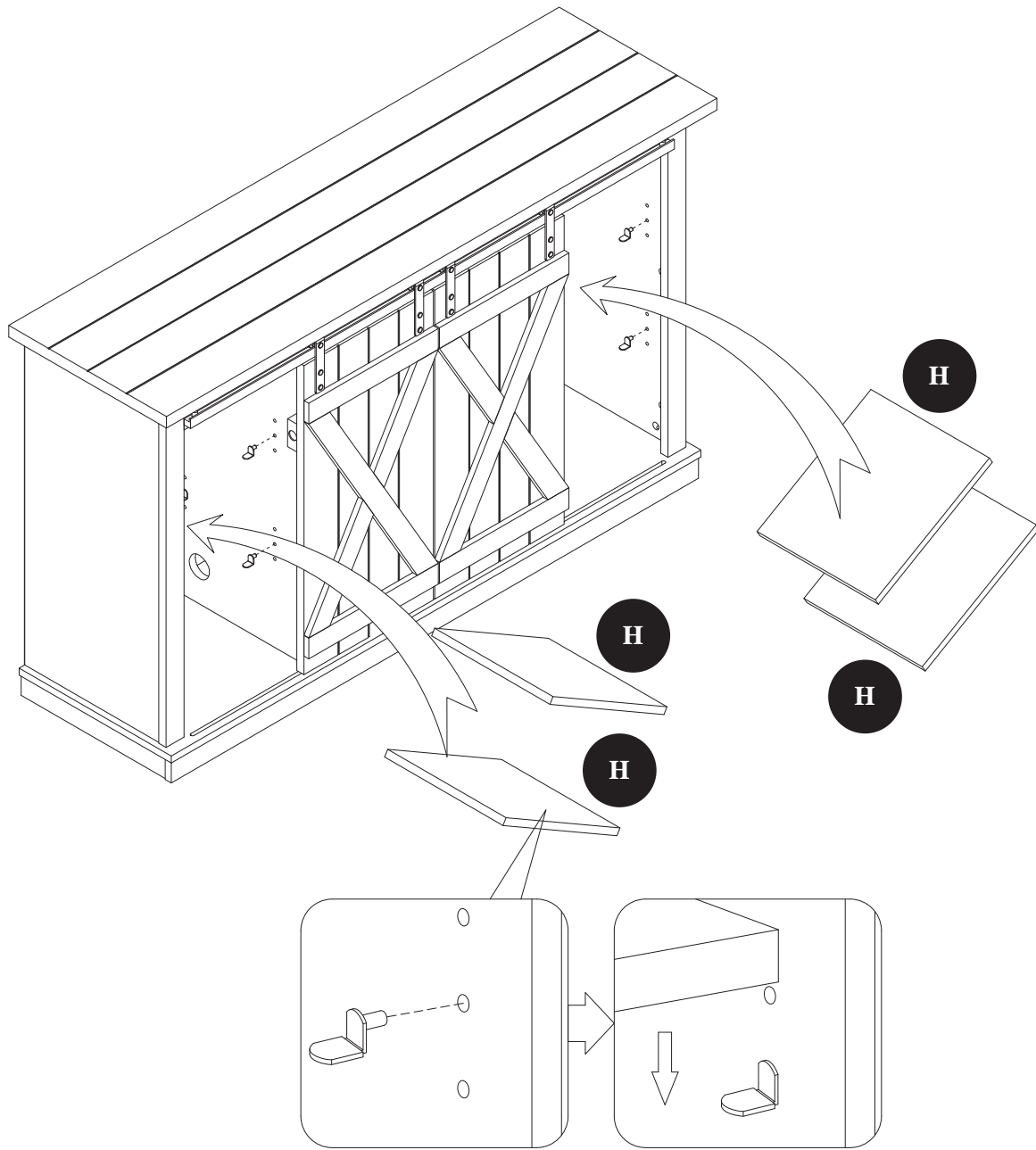

NN

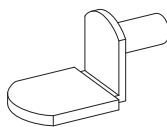

[x16]

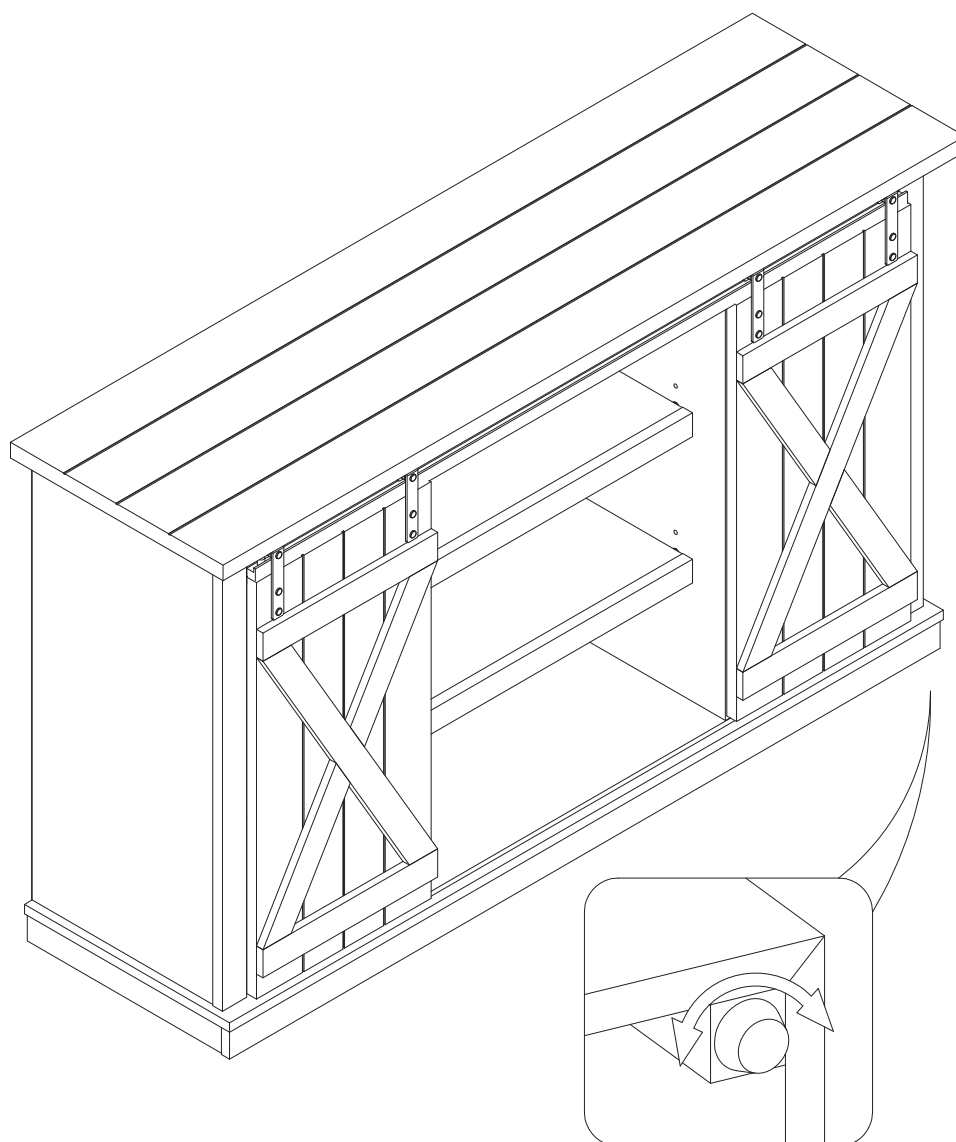

Note: It is very important that your unit is level in order for your doors to function properly. After moving your unit to its final location, you may need to adjust the floor levelers.

Remarque : Pour que les portes fonctionnent correctement, il est très important que l'appareil soit bien horizontal. Une fois que l'appareil sera arrivé sur son emplacement définitif, vous aurez peut-être besoin d'ajuster les réglages des pieds.

Nota: Para las puertas funcionan correctamente, es muy importante que la unidad esté nivelada. Una vez que la unidad llegue a su ubicación final, es posible que necesite ajustar la configuración de los pies.

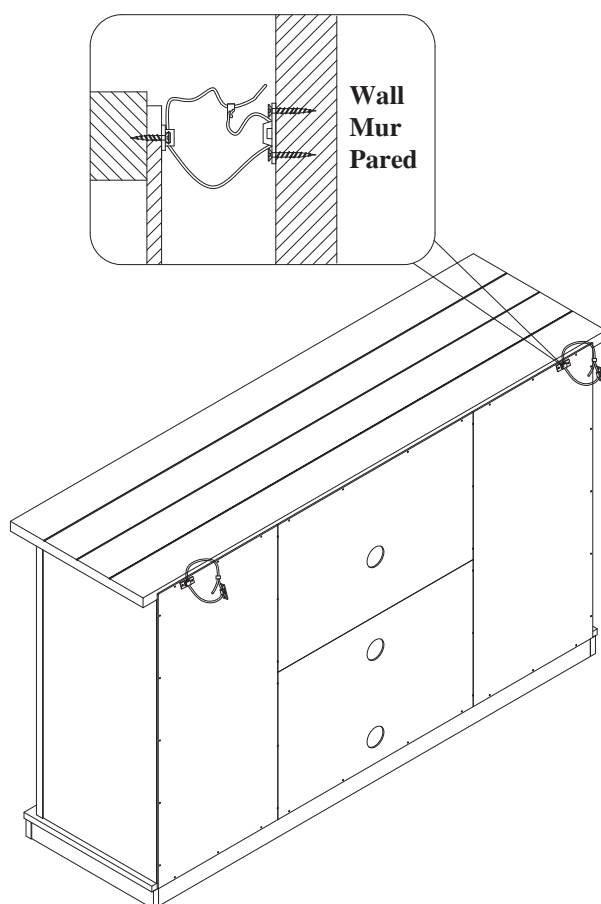

WARNING: You must install the tipping restraint hardware to help prevent any accidents or damage to the unit.

We strongly recommend mounting this hardware to a wall stud and your unit.

AVERTISSEMENT: Il est nécessaire d'installer les pièces d'arrimage anti basculement pour prévenir les accidents ou les dommages à l'unité.

Il est fortement recommandé de fixer ces pièces sur un poteau mural et sur le meuble.

ADVERTENCIA: Debe instalar el Herraje contra Caídas para evitar accidentes o que se dañe la unidad.

Recomendamos montar estos herrajes a un taco de pared y a la Unidad.

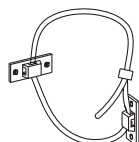

[x2]

CARE / MAINTENANCE

Care and Maintenance

- Use a soft, clean cloth that will not scratch the surface when dusting
- Use of furniture polish is not necessary. Should you choose to use polish, test first in an inconspicuous area.
- Using solvents of any kind on your furniture may damage the finish.
- Never use water to clean your furniture as it may cause damage to the finish.
- Always use coasters under beverage glasses and flowerpots.
- Liquid spills should be removed immediately, as it may damage the furniture. Use a soft, clean cloth and blot the spill gently. Avoid rubbing.
- Always use protective pads under hot dishes and plates. Heat can cause chemical changes that may create spotting within the furniture.

Further advice about wood furniture care

It is best to keep your furniture in a climate-controlled environment. Temperature and humidity changes can cause fading, warping, shrinking and splitting of wood. It is advised to keep furniture away from direct sunlight as sun may damage the finish. Proper care and cleaning at home will extend the life of your purchase. Following these important and helpful tips will enhance your furniture as it ages.

A touch- up pen has been provided to repair any small nicks or scratches that may occur during assembly or shipping. We hope you enjoy your purchase for many years. Thank you for your purchase!

SOIN / ENTRETIEN

Soin / Entretien

- Lors de l'époussetage, utilisez un chiffon doux et propre qui n'égratigne pas la surface.
- Il n'est pas nécessaire d'utiliser du poli à meuble. Si vous décidez d'utiliser du poli à meuble, veuillez d'abord en faire l'essai dans un endroit moins en évidence.
- L'utilisation de solvant de quelque sorte sur votre ameublement peut endommager le fini.
- Ne jamais utiliser d'eau pour nettoyer votre ameublement car cela peut endommager le fini.
- Utilisez toujours des dessous de verre sous les verres/tasses des breuvages et sous les pots à fleur.
- Tout déversement de liquide doit être enlevé immédiatement car cela peut endommager l'ameublement. Utilisez un chiffon doux et propre et éponger délicatement le déversement. Évitez de frotter.
- Utilisez toujours des tampons protecteurs sous les plats et les assiettes chaudes. La chaleur peut causer des changements chimiques qui peuvent créer des taches sur l'ameublement.

Autres conseils sur l'entretien du bois

Il est préférable de conserver votre ameublement dans un environnement dont le climat est contrôlé. Les changements de température et d'humidité peuvent causer une décoloration, un gauchissement, un rétrécissement et un fendillement du bois. Il est conseillé de garder l'ameublement éloigné des rayons directs du soleil puisque le soleil peut endommager son fini. Un nettoyage et un entretien approprié à domicile permettra d'allonger la durée de vie de votre achat. De suivre ces conseils importants et pratiques aidera votre ameublement à vieillir en beauté.

Un crayon à retouches est fourni pour réparer toute égratignure qui pourrait se produire lors de l'assemblage ou du transport. Nous vous souhaitons des années de plaisir avec l'utilisation de votre achat. Nous vous remercions pour votre achat!

CUIDADO / MANTENIMIENTO

Cuidado / Mantenimiento

- Use un paño suave y limpio que no raye la superficie cuando elimine el polvo.
- El uso de cera para muebles no es necesario. Si elige utilizar la cera, realice primero una prueba en un área discreta.
- Usar solventes de cualquier clase en sus muebles puede dañar el acabado.
- Nunca utilice agua para limpiar sus muebles, ya que puede causar daños en el acabado.
- Siempre utilice posavasos para colocar los vasos de bebidas y las macetas.
- Los derrames de líquidos se deben de secar inmediatamente, ya que pueden dañar el mueble. Use un paño suave y limpio y seque el derrame con cuidado. Evite frotar.
- Siempre utilice almohadillas protectoras debajo de los platos y vajillas calientes. El calor puede causar cambios químicos los cuales pueden crear manchas en los muebles.

Más consejos sobre el cuidado de los muebles de madera

Es mejor mantener sus muebles en un entorno climatizado. Los cambios en la temperatura y la humedad pueden desteñir, albear, encoger y fragmentar la madera. Se recomienda mantener los muebles lejos de la luz directa del sol, pues el sol puede dañar el acabado. La limpieza y el cuidado adecuados en el hogar extenderán la vida útil de su compra. Al seguir estos consejos importantes y útiles mejorará sus muebles a medida que pasa el tiempo.

Se ha proporcionado un marcador corrector para reparar cualquier raya o rasguño pequeño que se pueda producir durante el montaje o el envío. Esperamos que disfrute su compra durante muchos años. ¡Gracias por su compra!

REPLACEMENT PARTS PIECES DE REEMPLACEMENT PARTES DE REPUESTO

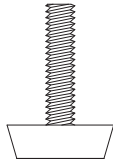

PP

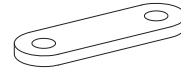

QQ

**NOTES
REMARQUES
NOTAS**

